



ИНСТРУМЕНТАЛЬНЫЙ ЗАВОД
«ВОСХОД»

ПЛАСТИНЫ СМЕННЫЕ ТВЕРДОСПЛАВНЫЕ ДЛЯ ТОКАРНОЙ ОБРАБОТКИ

ПЛАСТИНЫ СМЕННЫЕ ТВЕРДОСПЛАВНЫЕ ДЛЯ ТОКАРНОЙ ОБРАБОТКИ

СВН ПЛАСТИНЫ СМЕННЫЕ ТВЕРДОСПЛАВНЫЕ ДЛЯ ТОКАРНОЙ ОБРАБОТКИ

ИНСТРУМЕНТ ТОКАРНЫЙ СО СМЕННЫМИ ПЛАСТИНАМИ ДЛЯ НАРЕЗАНИЯ РЕЗЬБЫ

ИНСТРУМЕНТ ДЛЯ ОТРЕЗКИ И НАРЕЗАНИЯ КАНАВОК

СВЁРЛА СО СМЕННЫМИ ГОЛОВКАМИ

МНОГОФУНКЦИОНАЛЬНАЯ СИСТЕМА ТОРГОВОЙ МАРКИ «ИЗ ВОСХОДА»

ПЛАСТИНЫ ДЛЯ СВЁРЛ «SANDVIK» 880 СЕРИИ

ФРЕЗЫ РЕЗЬБОНАРЕЗНЫЕ СО СМЕННЫМИ ПЛАСТИНАМИ

СВЁРЛА МОНОЛИТНЫЕ ТВЕРДОСПЛАВНЫЕ УНИВЕРСАЛЬНЫЕ

ФРЕЗЫ СО СМЕННЫМИ ТВЕРДОСПЛАВНЫМИ ПЛАСТИНАМИ

ИНСТРУМЕНТ
МЕТАЛЛОРЕЖУЩИЙ
СО СМЕННЫМИ ПЛАСТИНАМИ
И МОНОЛИТНЫЙ ТВЕРДОСПЛАВНЫЙ

СВЁРЛА СО СМЕННЫМИ ПЛАСТИНАМИ

КАТАЛОГ 2026.1

ФРЕЗЫ УНИВЕРСАЛЬНЫЕ



НОВИНКИ



10.2022.

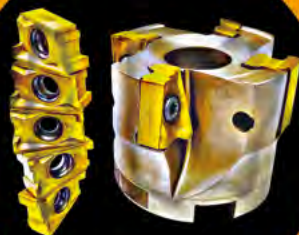

ФРЕЗЫ
СО СМЕННЫМИ
ПЛАСТИНАМИ

СВН
ПЛАСТИ

TOOLS

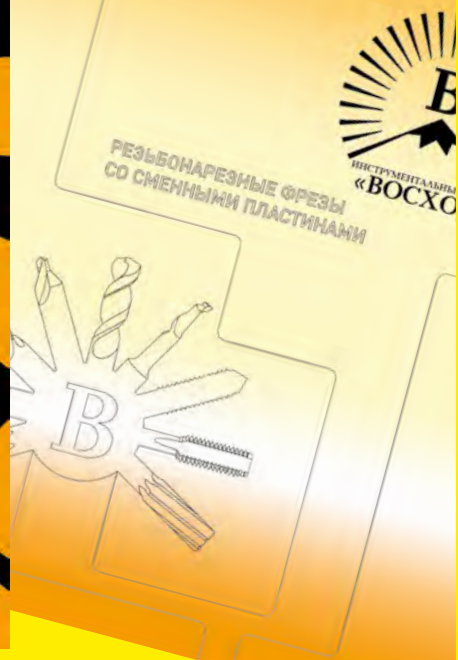

РЕЗЬБОНАРЕЗНЫЕ ФРЕЗЫ
СО СМЕННЫМИ ПЛАСТИНАМИ

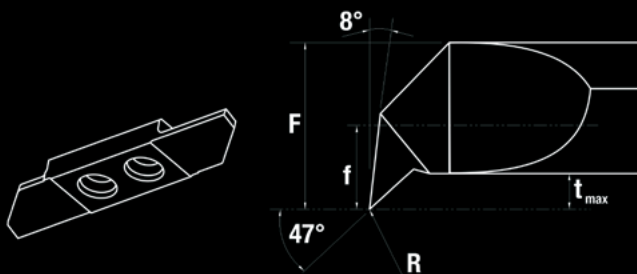

ИНСТРУМЕНТ
ДЛЯ ТОКАРНЫХ АВТОМАТОВ
ПРОДОЛЬНОГО ТОЧЕНИЯ



2022
TOOLS №1



СВЁРЛ

СО СМЕННЫМИ
ГОЛОВКАМИ













СО СМЕННЫМИ
ПЛАСТИНАМИ

НОВИНКИ, 2022
ФРЕЗЫ ДЛЯ ОБЩЕЙ ОБРАБОТКИ МАТЕРИАЛОВ



НОМЕНКЛАТУРА ПРОДУКЦИИ, ПРЕДСТАВЛЕННАЯ В КАТАЛОГЕ НЕ ОТРАЖАЕТ ВСЕЙ ПОЛНОТЫ АССОРТИМЕНТА И ТЕХНИЧЕСКИХ ВОЗМОЖНОСТЕЙ ТОРГОВОЙ МАРКИ «ИЗ ВОСХОД». КАТАЛОГ ПОСТОЯННО ОБНОВЛЯЕТСЯ И ДОПОЛНЯЕТСЯ. ВСЕ МАТЕРИАЛЫ, РАЗМЕЩЕННЫЕ В КАТАЛОГЕ НЕСУТ ИСКЛЮЧИТЕЛЬНО ИНФОРМАЦИОННЫЙ ХАРАКТЕР И НЕ ЯВЛЯЮТСЯ ДОГОВОРОМ ПУБЛИЧНОЙ ОФЕРТЫ. ПРОИЗВОДИТЕЛЬ ОСТАВЛЯЕТ ЗА СОБОЙ ПРАВО ВНОСИТЬ ИЗМЕНЕНИЯ В КОНСТРУКЦИЮ, ТЕХНИЧЕСКИЕ ХАРАКТЕРИСТИКИ, МАТЕРИАЛЫ ИЗГОТОВЛЕНИЯ, ПОКРЫТИЯ, ВНЕШНИЙ ВИД И КОМПЛЕКТАЦИЮ ТОВАРА БЕЗ ПРЕДВАРИТЕЛЬНОГО УВЕДОМЛЕНИЯ.

СОДЕРЖАНИЕ		Стр.
	РАЗДЕЛ 1. ПЛАСТИНЫ СМЕННЫЕ ТВЕРДОСПЛАВНЫЕ ДЛЯ ТОКАРНОЙ ОБРАБОТКИ	5
	СИСТЕМА ОБОЗНАЧЕНИЙ ТОКАРНЫХ ПЛАСТИН	6
	СПЛАВЫ ДЛЯ ТОКАРНОЙ ОБРАБОТКИ	8
	РЕЖУЩИЕ ГЕОМЕТРИИ. НЕГАТИВНЫЕ СМЕННЫЕ ПЛАСТИНЫ	10
	КОНСТРУКТИВ ОСНОВНЫХ ГЕОМЕТРИЙ	11
	РЕЖУЩИЕ ГЕОМЕТРИИ. ПОЗИТИВНЫЕ СМЕННЫЕ ПЛАСТИНЫ	12
	НЕГАТИВНЫЕ ТВЕРДОСПЛАВНЫЕ ПЛАСТИНЫ	14
	ПОЗИТИВНЫЕ ТВЕРДОСПЛАВНЫЕ ПЛАСТИНЫ	24
	РАЗДЕЛ 2. СВН ПЛАСТИНЫ СМЕННЫЕ ТВЕРДОСПЛАВНЫЕ ДЛЯ ТОКАРНОЙ ОБРАБОТКИ	33
	СИСТЕМА ОБОЗНАЧЕНИЙ ПЛАСТИН СВН	34
	СОРТА СВН И ИХ ПРИМЕНЕНИЕ	36
	ПЛАСТИНЫ НЕГАТИВНЫЕ	37
	ПЛАСТИНЫ ПОЗИТИВНЫЕ	43
	РАЗДЕЛ 3. ИНСТРУМЕНТ ТОКАРНЫЙ СО СМЕННЫМИ ПЛАСТИНАМИ ДЛЯ НАРЕЗАНИЯ РЕЗЬБЫ	45
	РЕЗЬБОНАРЕЗНЫЕ ДЕРЖАВКИ НАРУЖНЫЕ	46
	РЕЗЬБОНАРЕЗНЫЕ ДЕРЖАВКИ ВНУТРЕННИЕ	48
	ОПИСАНИЕ ТВЕРДЫХ СПЛАВОВ	50
	ПЛАСТИНЫ ДЛЯ НАРУЖНОЙ И ВНУТРЕННЕЙ РЕЗЬБЫ	51
	НЕПОЛНЫЙ ПРОФИЛЬ 60°. МЕТРИЧЕСКАЯ РЕЗЬБА	51
	ПОЛНЫЙ ПРОФИЛЬ 60°. МЕТРИЧЕСКАЯ РЕЗЬБА	52
	РАЗДЕЛ 4. ИНСТРУМЕНТ ДЛЯ ОТРЕЗКИ И НАРЕЗАНИЯ КАНАВОК	53
	ДЕРЖАВКИ ДЛЯ ОБРАБОТКИ КАНАВОК И ТОЧЕНИЯ	54
	ДЕРЖАВКИ ДЛЯ ОБРАБОТКИ ГЛУБОКИХ ТОРЦЕВЫХ КАНАВОК И ТОЧЕНИЯ	57
	ДЕРЖАВКИ ДЛЯ ОБРАБОТКИ ТОРЦЕВЫХ (АКСИАЛЬНЫХ) КАНАВОК И ТОЧЕНИЯ	58
	ДЕРЖАВКИ ДЛЯ ОБРАБОТКИ МЕЛКИХ ТОРЦЕВЫХ (АКСИАЛЬНЫХ) КАНАВОК ВНУТРИ ОТВЕРСТИЯ	59
	ДЕРЖАВКИ ДЛЯ ОБРАБОТКИ ВНУТРЕННИХ РАДИАЛЬНЫХ КАНАВОК И ТОЧЕНИЯ	60
	ОПИСАНИЕ ТВЕРДЫХ СПЛАВОВ	61
	ГЕОМЕТРИИ ПЛАСТИН И ИХ ПРИМЕНЯЕМОСТЬ	62
	ПЛАСТИНЫ ДЛЯ ОТРЕЗКИ И ОБРАБОТКИ КАНАВОК	63
	РАЗДЕЛ 5. СВЁРЛА	65
	5.1. СВЁРЛА МОНОЛИТНЫЕ ТВЕРДОСПЛАВНЫЕ УНИВЕРСАЛЬНЫЕ	66
	СВЁРЛА С ПЛОСКИМ ТОРЦОМ 180°	68
	СВЁРЛА ЦЕНТРОВОЧНЫЕ ДЛЯ СТАНКОВ С ЧПУ	69
	МИКРОСВЁРЛА УНИВЕРСАЛЬНЫЕ. ОБЩАЯ ОБРАБОТКА МАТЕРИАЛОВ	70
	МИКРОСВЁРЛА УНИВЕРСАЛЬНЫЕ. ОБРАБОТКА МЯГКИХ МАТЕРИАЛОВ, СПЛАВОВ ЦВЕТНЫХ МЕТАЛЛОВ, ПЛАСТИКОВ...	76
	5.2. СВЁРЛА СО СМЕННЫМИ ГОЛОВКАМИ	81
КОРПУСА	82	
	ТИПЫ СВЕРЛИЛЬНЫХ ГОЛОВОК	84
	ГОЛОВКИ СВЕРЛИЛЬНЫЕ СМЕННЫЕ	85
	РЕКОМЕНДУЕМЫЕ РЕЖИМЫ РЕЗАНИЯ	88
	5.3. СВЁРЛА СО СМЕННЫМИ ПЛАСТИНАМИ	89
	ОПИСАНИЕ. ПЛАСТИНЫ	90
	КОРПУСА	91
	РЕКОМЕНДУЕМЫЕ РЕЖИМЫ РЕЗАНИЯ ДЛЯ 2, 3, 4XD	97
	РЕКОМЕНДУЕМЫЕ РЕЖИМЫ РЕЗАНИЯ ДЛЯ 5XD	98
	5.4. ПЛАСТИНЫ ДЛЯ СВЁРЛ «SANDVIK» 880 СЕРИИ	99
	5.5. МНОГОФУНКЦИОНАЛЬНАЯ СИСТЕМА ТОРГОВОЙ МАРКИ «ИЗ ВОСХОД»	103
	РАЗДЕЛ 6. ФРЕЗЫ СО СМЕННЫМИ ТВЕРДОСПЛАВНЫМИ ПЛАСТИНАМИ	107
	6.1. ФРЕЗЫ ДЛЯ ОБРАБОТКИ ПАЗОВ, УСТУПОВ И ПЛОСКОСТЕЙ	108
	6.2. ФРЕЗЫ ДЛЯ ОБРАБОТКИ ПЛОСКОСТЕЙ	133
	6.3. ФРЕЗЫ ДЛЯ ВЫСОКИХ ПОДАЧ	147
	6.4. ФРЕЗЫ КАНАВОЧНЫЕ	153
	6.5. ФРЕЗЫ ДИСКОВЫЕ	157
	РАЗДЕЛ 7. ФРЕЗЫ РЕЗЬБОНАРЕЗНЫЕ СО СМЕННЫМИ ПЛАСТИНАМИ	163
	РЕЗЬБОНАРЕЗНЫЕ ФРЕЗЫ С ТАНГЕНЦИАЛЬНЫМ КРЕПЛЕНИЕМ ПЛАСТИН	164
	ПЛАСТИНЫ	165
	РЕЗЬБОНАРЕЗНЫЕ ФРЕЗЫ С ТОРЦОВЫМ КРЕПЛЕНИЕМ ПЛАСТИН	167
	ПЛАСТИНЫ	168
	РАЗДЕЛ 8. ФРЕЗЫ УНИВЕРСАЛЬНЫЕ. ОБЩАЯ ОБРАБОТКА МАТЕРИАЛОВ ГРУПП Р, М, К	169
	8.1. ФРЕЗЫ С ПЛОСКИМ ТОРЦОМ	170
	8.2. ФРЕЗЫ СО СФЕРИЧЕСКИМ ТОРЦОМ	193
	8.3. ФРЕЗЫ СПЕЦИАЛЬНОЙ КОНСТРУКЦИИ	205

ПЛАСТИНЫ

**СМЕННЫЕ ТВЕРДОСПЛАВНЫЕ
ДЛЯ ТОКАРНОЙ ОБРАБОТКИ**

РАЗДЕЛ 1

1. Форма пластины	2. Задний угол пластины	3. Класс точности	4. Исполнение пластины	5. Размер пластины	6. Толщина пластины
D	N	G	A	15	06

Обозначение	Угол	Форма пластины
A	85°	
B	82°	
C	80°	
D	55°	
E	75°	
K	55°	
M	86°	
N	55°	
V	35°	
H	120°	
L	90°	
O	135°	
P	108°	
R	—	
S	90°	
T	60°	
W	80°	

Задний угол пластины	
A	3°
B	5°
C	7°
D	15°
E	20°
F	25°
G	30°
N	0°
P	11°

Класс точности	Поля допуска		
	D	B	S
C	±0,025	±0,013	±0,025
H	±0,013	±0,013	±0,025
E	±0,025	±0,025	±0,025
G	±0,025	±0,025	±0,013
M	см. ниже	см. ниже	±0,013
U	см. ниже	см. ниже	±0,013

D	Поля допуска на размер D				
	Допуск класс M		Допуск класс U		
	Формы				
	S, T, C, R, W	D	V	S, T, C	
3,97	0,05	—	—	—	
4,76	0,05	—	—	0,08	
5,56	0,05	0,05	0,05	0,08	
6,35	0,05	0,05	0,05	0,08	
7,94	0,05	0,05	0,05	0,08	
9,52	0,05	0,05	0,05	0,08	
11,11	0,08	0,08	0,08	0,13	
12,70	0,08	0,08	0,08	0,13	
14,29	0,08	0,08	0,08	0,13	
15,88	0,10	0,10	0,10	0,18	
17,46	0,10	0,10	0,10	0,18	
19,05	0,10	0,10	0,10	0,18	
22,22	0,13	—	—	0,25	
25,40	0,13	—	—	0,25	
31,75	0,15	—	—	0,25	

D	Поля допуска на размер B				
	Допуск класс M		Допуск класс U		
	Формы				
	S, T, C, R, W	D	V	S, T, C	
3,97	0,08	—	—	—	
4,76	0,08	—	—	0,13	
5,56	0,08	0,11	—	0,13	
6,35	0,08	0,11	—	0,13	
7,94	0,08	0,11	—	0,13	
9,52	0,08	0,11	0,18	0,13	
11,11	0,13	0,15	—	—	
12,70	0,13	0,15	0,25	0,20	
14,29	0,13	0,15	—	—	
15,88	0,15	0,18	—	0,27	
17,46	0,15	0,18	—	0,27	
19,05	0,15	0,18	—	0,27	
22,22	0,15	—	—	0,38	
25,40	0,18	—	—	0,38	
31,75	0,20	—	—	0,38	

Обозначение	Исполнение пластины
N	
R	
F	
A	
M	
G	
W	
T	
Q	
U	
B	
H	
C	
J	
X,V	Специальная конструкция

Длина режущей кромки	D мм							
	C	D	R	S	T	V	W	
3,97	S4	04	03	03	06	—	—	
4,76	04	05	04	04	08	08	S3	
5,56	05	06	05	05	09	09	03	
6,00	—	—	06	—	—	—	—	
6,35	06	07	06	06	11	11	04	
7,94	08	09	07	07	13	13	05	
8,00	—	—	08	—	—	—	—	
9,52	09	11	09	09	16	16	06	
10,00	—	—	10	—	—	—	—	
11,11	11	13	11	11	19	19	07	
12,00	—	—	12	—	—	—	—	
12,70	12	15	12	12	22	22	08	
14,29	14	17	14	14	24	24	09	
15,88	16	19	15	15	27	27	10	
16,00	—	—	16	—	—	—	—	
17,46	17	21	17	17	30	30	11	
19,05	19	23	19	19	33	33	13	
20,00	—	—	20	—	—	—	—	
22,22	22	27	22	22	38	38	15	
25,00	—	—	25	—	—	—	—	
25,40	25	31	25	25	44	44	17	
31,75	32	38	31	31	54	54	21	
32,00	—	—	32	—	—	—	—	

D мм	Толщина
—	0,79
T0	1,00
01	1,59
T1	1,98
02	2,38
03	3,18
T3	3,97
04	4,76
05	5,56
06	6,35
07	7,94
09	9,52
11	11,11
12	12,70

D — диаметр, вписанный в пластину
 S — толщина
 R — радиус скругления
 B — см. рисунок

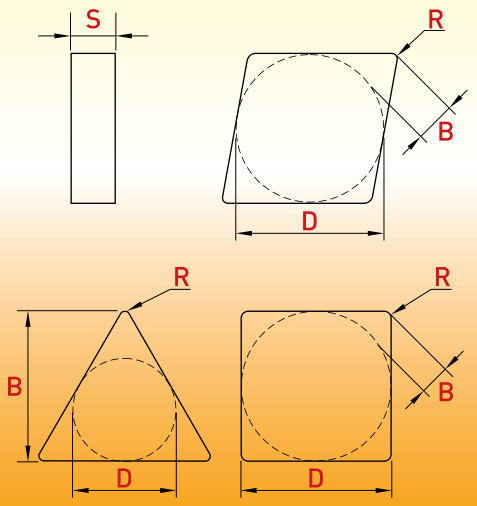

7. Радиус скругления

04

D мм	Радиус скругления
X0	0,4
01	0,1
02	0,2
04	0,4
08	0,8
12	1,2
16	1,6
20	2,0
24	2,4
28	2,8
32	3,2
00	Круглая режущая пластина
MO	

8. Исполнение пластины (дополнительно)

N

Обозначение и исполнение
<p>L</p> <p>ЛЕВОЕ</p>
<p>R</p> <p>ПРАВОЕ</p>
<p>N</p> <p>НЕЙТРАЛЬНОЕ</p>

9. Режущая кромка (дополнительно)

S

Обозначение	Форма режущей кромки
F	<p>ОСТРАЯ</p>
E	<p>СКРУГЛЕННАЯ</p>
T	<p>С ФАСКОЙ</p>
S	<p>С ФАСКОЙ И СКРУГЛЕНИЕМ</p>

10. Стружколом

NSF



СПЛАВЫ ДЛЯ ТОКАРНОЙ ОБРАБОТКИ

МАРКА СПЛАВА	ОПИСАНИЕ		05	10	15	20	25	30	35	40	Vc м/мин	
OP25A	Твердосплавная основа с относительно высоким объемным содержанием карбидов, с хорошей устойчивостью к деформации и ударной вязкостью. Покрытие MT-TiCN + Al2O3 + TiN имеет очень хорошее качество поверхности и позволяет легко обнаруживать износ. Основное назначение — получистовая и черновая обработка сталей.	P									70-430	
		M										
		K									70-200	
		N										
		S										
		H										
OP15	Твердосплавная основа с высоким объемным содержанием карбидов и небольшим содержанием связки. Комбинированное покрытие TiCN и Al2O3 со специальной обработкой поверхности обеспечивает высокую износостойкость. Основное назначение — получистовая и чистовая обработка сталей.		05	10	15	20	25	30	35	40		
		P										70-430
		M										
		K										100-250
		N										
		S										
OP25	Твердосплавная основа с высоким объемным содержанием карбидов и небольшим содержанием связки. Комбинированное покрытие TiCN и Al2O3 со специальной обработкой поверхности обеспечивает высокую износостойкость. Основное назначение — получистовая и чистовая обработка сталей.		05	10	15	20	25	30	35	40		
		P										70-430
		M										
		K										70-200
		N										
		S										
OP20	Твердосплавная основа с высоким объемным содержанием карбидов и средним содержанием связки. Подложка сочетается с прочной текстурой покрытия TiCN и Al2O3. Благодаря специальной обработке поверхности обладает прекрасной стойкостью к истиранию. Основное назначение — общая токарная обработка сталей.		05	10	15	20	25	30	35	40		
		P										70-430
		M										
		K										70-200
		N										
		S										
OK15	Твердая подложка идеально сочетается со сверхтолстым покрытием TiCN и Al2O3. Сплав оптимизирован для лучшей износостойкости. Основное назначение — получистовая и чистовая обработки чугунов.		05	10	15	20	25	30	35	40		
		P										200-460
		M										
		K										200-380
		N										
		S										
OK20D	Основа из крупнозернистого твердого сплава с хорошей вязкостью сочетается с износостойким сверхтолстым CVD-покрытием из оксида алюминия, со специальной обработкой поверхности, которая обеспечивает хорошую шероховатость и износостойкость. Основное назначение — получистовая обработка (от средней до прерывистой) чугунов.		05	10	15	20	25	30	35	40		
		P										180-400
		M										
		K										180-350
		N										
		S										
OK25	Основа из среднезернистого твердого сплава крупности в сочетании с толстым износостойким покрытием TiCN+Al2O3 со специальной обработкой поверхности имеет повышенную износостойкость. Основное назначение — высокоскоростная получистовая обработка чугунов.		05	10	15	20	25	30	35	40		
		P										180-400
		M										
		K										180-350
		N										
		S										
OPM52	Твердый сплав с высоким содержанием Со в сочетании с тонким MT-CVD покрытием TiCN+Al2O3, оптимизированное для высокой ударпрочности и износостойкости. Основное назначение — общая обработка сталей.		05	10	15	20	25	30	35	40		
		P										110-220
		M										100-200
		K										
		N										
		S										
OP20A	Прочный среднезернистый твердый сплав с ультротонким MT-CVD покрытием TiCN+Al2O3 со специальной обработкой поверхности. Отличается хорошей ударной вязкостью и стойкостью к истиранию. Основное применение — обработка нержавеющих сталей.		05	10	15	20	25	30	35	40		
		P										110-220
		M										100-200
		K										
		N										
		S										
OM10	Твердый сплав с средним содержанием кобальта и высоким объемным содержанием карбидов. Тонкое покрытие TiCN+Al2O3 со специальной обработкой поверхности придает прекрасную износостойкость. Основное применение — высокоскоростная токарная обработка нержавеющих сталей.		05	10	15	20	25	30	35	40		
		P										150-280
		M										120-250
		K										
		N										
		S										30-70

CVD

	МАРКА СПЛАВА	ОПИСАНИЕ		05	10	15	20	25	30	35	40	Vc м/мин	
PVD	ОРМ215	Сверхмелкозернистый твердый сплав с высоким содержанием кобальта. Превосходная прочность режущей кромки в сочетании с хорошей термостойкостью. PVD износостойкое покрытие с очень малым коэффициентом трения и высокой нано-твердостью обладающим высокой стойкостью. Основное применение — точение сталей и нержавеющей сталей.	P										
			M										120–250
			K										
			N										
			S										30–50
			H										
	ОРМ25А	Мелкозернистый твердый сплав с высоким содержанием кобальта придает высокую прочность режущей кромке в сочетании с хорошей термостойкостью. PVD износостойкое покрытие с очень малым коэффициентом трения и высокой нано-твердостью обладающим высокой стойкостью. Основное применение — точение сталей и нержавеющей сталей.	P										
			M										100–200
			K										
			N										
			S										30–50
			H										
ОРМ25	Мелкозернистый твердый сплав с высоким содержанием кобальта. Превосходная прочность режущей кромки в сочетании с хорошей термостойкостью. PVD износостойкое покрытие с очень малым коэффициентом трения и высокой температурой окислации, хорошей нано-твердостью. Основное применение — фрезерование и сверление сталей и нержавеющей сталей.	P											
		M										100–200	
		K											
		N											
		S										30–50	
		H											
БЕЗ ПОКРЫТИЯ	ОН10	Мелкие частицы карбида вольфрама и сверхтонкого порошка кобальта в сочетании создают полностью плотную внутреннюю организацию за счет спекания при низком давлении. Обладая высокой твердостью, высокой прочностью, хорошей теплопроводностью и другими характеристиками, подходит для цветных металлов, железа и других материалов, точности получистовой обработки. Сплав получен путем спекания при низком давлении мелкозернистого карбида вольфрама с сверхмелкозернистой связкой (кобальт). В результате сплав обладает однородной плотной структурой, высокой твердостью и одновременно высокой прочностью, хорошей теплопроводностью и другими характеристиками. Предназначен для чистовой-получистовой обработки цветных металлов и их сплавов.	P										
			M										
			K										
			N										200–1000
			S										
			H										

	Обозначение	Описание	Геометрия	P M K N S H	Режимы
	ЧИСТОВЫЕ	NPF	Разработан для чистового точения стали. Обеспечивает высокую точность и чистоту поверхности детали. Острая режущая кромка имеет низкие силы резания и стабильное дробление стружки. Подходит для нежестких склонных к вибрациям деталей.		
NMF1		Разработан для чистовой и получистовой обработки нержавеющей и труднообрабатываемых сталей. Острая режущая кромка позволяет уменьшить сопротивление резанию и обеспечивает хорошее качество поверхности при стабильном точении.			
NSF		Разработан для чистовой обработки нержавеющей и жаропрочных сплавов. Острый, двойной угол режущей кромки обеспечивает низкое сопротивление резанию, что позволяет эффективно дробить стружку, снижать температуру в зоне резания, исключить наростообразование, упрочнение и другие проблемы при точении жаропрочных сплавов. А также обеспечивает высокое качество обработанной поверхности.			
NPM		Разработан для получистового точения стали и нержавеющей стали. Универсальный стружколом подходящий от чистового до черного точения. Обеспечивает хорошее дробление стружки на большом диапазоне режимов резания. Рекомендован как основной стружколом для вашего производства.			
NMF		Разработан для получистовой обработки нержавеющей и жаропрочных сплавов. Обеспечивает как низкое сопротивление резанию так и хорошее сопротивление к прерывистому точению. Также как и NSF позволяет эффективно дробить стружку, снижать температуру в зоне резания, исключать наростообразование, упрочнение и другие проблемы при точении жаропрочных сплавов.			
ПОЛУЧИСТОВЫЕ	NMM	Разработана для получистовой обработки нержавеющей и труднообрабатываемых сталей. Подходит для стабильного и прерывистого точения и эффективно избегает наростообразование на пластине.			
	Не имеет обозначения	Простейшая геометрия для негативных пластин. Разработана для получистовой обработки материалов групп P и K.			
	NSO	Подходит для обработки заготовок из высокотемпературных сплавов.			

ЦЕРНОВЫЕ	Обозначение	Описание	Геометрия	P M K N S H	Режимы
	NPR	Разработан для черного точения сталей. Подходит для грубой, прерывистой обработки сталей при низких и сред-них скоростях резания. Также может быть использован для получерновой обработки сталей и нержавеющей сталей.			
	NPR1	Разработан для тяжелого, черного точения сталей. Рекомендован для односторонних негативных пластин; тяжелого, грубого, прерывистого точения сталей и чугунов.			
	Без геометрии	Пластины с плоской поверхностью без стружколома.			

КОНСТРУКТИВ ОСНОВНЫХ ГЕОМЕТРИЙ

Обозначение	NPF	NMF1	NMF	NPR	NPM	NSF	NMM
Геометрия							

	Обозначение	Описание	Геометрия	P M K N S H	Режимы
	ЧИСТОВЫЕ	PTF	Стружколом для позитивных пластин (с задним углом). Предназначен для чистового точения сталей и нержавеющей сталей. Низкие силы резания обеспечивают высокую чистоту и точность обрабатываемой поверхности на средних и высоких скоростях резания при стабильном точении.		
CSF		Разработан для чистовой обработки нержавеющей и жаропрочных сплавов. Острый, двойной угол режущей кромки обеспечивает низкое сопротивление резанию, что позволяет эффективно дробить стружку, снижать температуру в зоне резания, исключить наростообразование, упрочнение и другие проблемы при точении жаропрочных сплавов. А также обеспечивает высокое качество обработанной поверхности.			
PTM		Универсальный стружколом для позитивных пластин (с задним углом). Подходит от чистового до легкого черного точения сталей и нержавеющей сталей на средних скоростях резания. Хорошее стружкодробление на большом диапазоне режимов резания и универсальность применения делает данный стружколом предпочтительным для основного применения на производстве.			
ПОЛУЧИСТОВЫЕ	PGM	Новый стружколом для позитивных пластин (с задним углом). Благодаря большому переднему углу, переменной толщине режущей кромки и острому краю, данный стружколом значительно снижает силы резания и повышает чистоту обрабатываемой поверхности. Применяется для получистовой обработки сталей и нержавеющей сталей.			
	AL	Усовершенствованный трехмерный стружколом с достаточным объемом пространства для формирования и эвакуации стружки, что гарантирует эффективность стружкообразования и удаления стружки. Большой передний угол и задний угол образуют острую режущую кромку, обеспечивающую высокую скорость и низкие усилия резания. Специальная конструкция режущей кромки позволяет эффективно контролировать направление потока стружки. Великолепная полировка передней поверхности эффективно снижает вероятность налипания обрабатываемого материала и наростообразования на режущей кромке, в результате чего достигается хорошее качество поверхности и высокая стойкость пластины. Обработка материалов групп N.			
	PSO	Подходит для обработки заготовок из высокотемпературных сплавов			
ЧЕРНОВЫЕ	PTR	Стружколом для позитивных пластин (с задним углом). Подходит для получистового и черного точения сталей, нержавеющей сталей и чугуна. Прочная режущая кромка обеспечивает стабильную обработку и хорошее стружкодробление при высоких подачах на средних скоростях резания.			

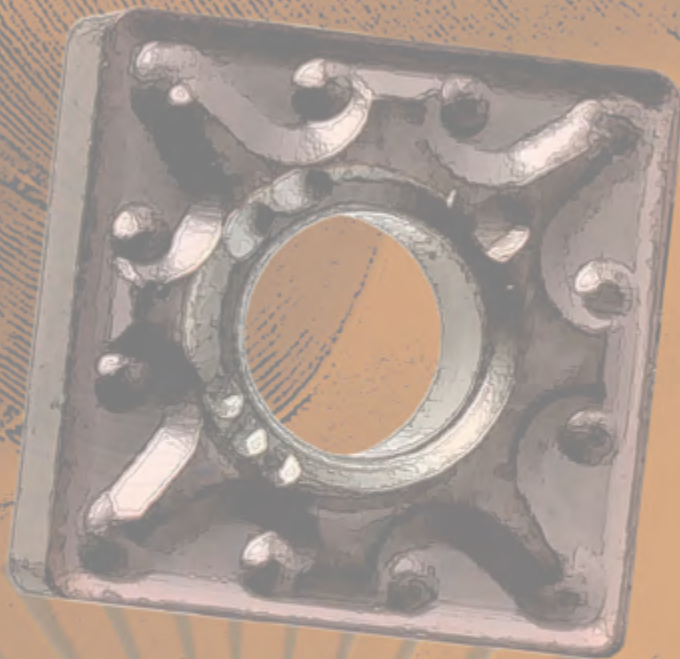

ИНСТРУМЕНТНЫЙ ЗАВОД
ВСЕОБЩАЯ

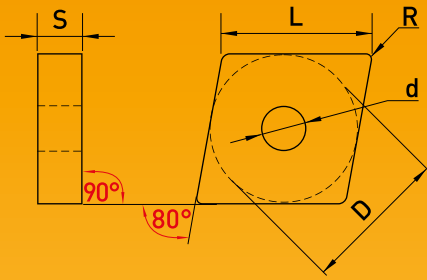

P	★	★	★	★	☆				☆	☆	☆			
M						★	★	★	★					☆
K	☆	☆	☆	☆								★	★	★
N														★
S							★	★	★	★				★
H											☆			

Обработка	Форморазмер пластины	L мм	D мм	S мм	d мм	R мм	Сплавы													
							OP25A	OP15	OP25	OP20	OM10	OPM215	OPM25A	OPM25	OK15	OK25	OK20D	ON10	OSM15	
Чистовая	CNMG120404-NPF	12.9	12.700	4.76	5.16	0.4	●	●	●											
	CNMG120408-NPF	12.9	12.700	4.76	5.16	0.8	●	●	●											
	CNMG120404-NMF1	12.9	12.700	4.76	5.16	0.4					●	●	●	●						
	CNMG120408-NMF1	12.9	12.700	4.76	5.16	0.8					●	●	●	●						
	CNMG090304-NSF	9.7	9.525	3.18	3.81	0.4					●	●	●	●						
	CNMG120404-NSF	12.9	12.700	4.76	5.16	0.4					●	●	●	●						
Получистовая	CNMG120404-NPM	12.9	12.700	4.76	5.16	0.4	●	●	●									●		
	CNMG120408-NPM	12.9	12.700	4.76	5.16	0.8	●	●	●									●		
	CNMG120412-NPM	12.9	12.700	4.76	5.16	1.2	●	●	●									●		
	CNMG120416-NPM	12.9	12.700	4.76	5.16	1.6	●	●	●									●		
	CNMG160608-NPM	16.1	15.875	6.35	6.35	0.8	●	●	●									●		
	CNMG160612-NPM	16.1	15.875	6.35	6.35	1.2	●	●	●									●		
	CNMG160616-NPM	16.1	15.875	6.35	6.35	1.6	●	●	●									●		
	CNMG190608-NPM	19.3	19.050	6.35	7.94	0.8	●	●	●									●		
	CNMG190612-NPM	19.3	19.050	6.35	7.94	1.2	●	●	●									●		
	CNMG190616-NPM	19.3	19.050	6.35	7.94	1.6	●	●	●									●		
	CNMG120404-NMM	12.9	12.700	4.76	5.16	0.4			●	●	●	●	●							
	CNMG120408-NMM	12.9	12.700	4.76	5.16	0.8			●	●	●	●	●							
	CNMG160608-NMM	16.1	15.875	6.35	6.35	0.8			●	●	●	●	●							
	CNMG090308-NMF	9.7	9.525	3.18	3.81	0.8				●	●	●	●	●						
	CNMG120408-NMF	12.9	12.700	4.76	5.16	0.8				●	●	●	●	●						
	CNMG120412-NMF	12.9	12.700	4.76	5.16	1.2				●	●	●	●	●						
	CNMG160612-NMF	16.1	15.875	6.35	6.35	1.2				●	●	●	●	●						
	CNMG120404-NSO	12.9	12.700	4.76	5.16	0.4				●									●	
	CNMG120408-NSO	12.9	12.700	4.76	5.16	0.8				●									●	
	CNMG120412-NSO	12.9	12.700	4.76	5.16	1.2				●									●	
	CNMG120404	12.9	12.700	4.76	5.16	0.4	●	●	●	●								●	●	●
	CNMG120408	12.9	12.700	4.76	5.16	0.8	●	●	●	●								●	●	●
	CNMG120412	12.9	12.700	4.76	5.16	1.2	●	●	●	●								●	●	●
	CNMG160608	16.1	15.875	6.35	6.35	0.8	●	●	●	●								●	●	●
CNMG160612	16.1	15.875	6.35	6.35	1.2	●	●	●	●								●	●	●	
CNMG160616	16.1	15.875	6.35	6.35	1.6	●	●	●	●								●	●	●	
CNMG190608	19.3	19.050	6.35	7.94	0.8	●	●	●	●								●	●	●	
CNMG190612	19.3	19.050	6.35	7.94	1.2	●	●	●	●								●	●	●	
CNMG190616	19.3	19.050	6.35	7.94	1.6	●	●	●	●								●	●	●	

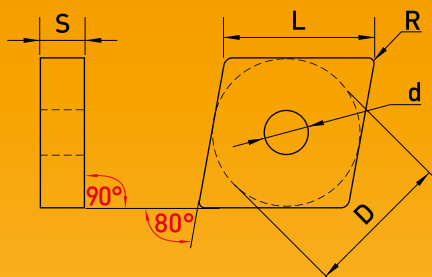





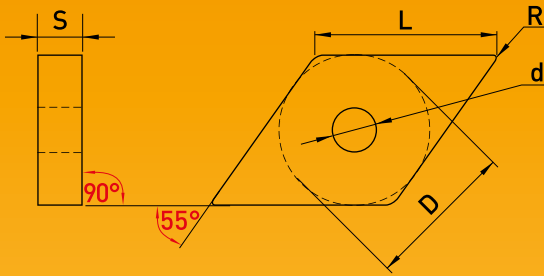

P	★	★	★	★	☆					☆	☆	☆		
M						★	★	★	★					☆
K	☆	☆	☆	☆							★	★	★	
N														★
S							★	★	★	★				★
H											☆			

Обработка	Форморазмер пластины	L мм	D мм	S мм	d мм	R мм	Сплавы																
							OP25A	OP15	OP25	OP20	OM10	OPM215	OPM25A	OPM25	OK15	OK25	OK20D	ON10	OSM15				
Черновая		CNMG120408-NPR	12.9	12.700	4.76	5.16	0.8	●	●	●	●								●				
		CNMG120412-NPR	12.9	12.700	4.76	5.16	1.2	●	●	●	●									●			
		CNMG120416-NPR	12.9	12.700	4.76	5.16	1.6	●	●	●	●									●			
		CNMG160608-NPR	16.1	15.875	6.35	6.35	0.8	●	●	●	●									●			
		CNMG160612-NPR	16.1	15.875	6.35	6.35	1.2	●	●	●	●									●			
		CNMG160616-NPR	16.1	15.875	6.35	6.35	1.6	●	●	●	●									●			
		CNMG190608-NPR	19.3	19.050	6.35	7.94	0.8	●	●	●	●									●			
		CNMG190612-NPR	19.3	19.050	6.35	7.94	1.2	●	●	●	●									●			
		CNMG190616-NPR	19.3	19.050	6.35	7.94	1.6	●	●	●	●									●			
		Черновая		CNMA120404	12.9	12.700	4.76	5.16	0.4											●	●	●	
CNMA120408	12.9			12.700	4.76	5.16	0.8												●	●	●		
CNMA120412	12.9			12.700	4.76	5.16	1.2													●	●	●	
CNMA120416	12.9			12.700	4.76	5.16	1.6														●	●	●
CNMA160608	16.1			15.875	6.35	6.35	0.8													●	●	●	
CNMA160612	16.1			15.875	6.35	6.35	1.2													●	●	●	
CNMA160616	16.1			15.875	6.35	6.35	1.6													●	●	●	
CNMA160620	16.1			15.875	6.35	6.35	2.0													●	●	●	
CNMA190612	19.3			19.050	6.35	7.94	1.2													●	●	●	
CNMA190616	19.3			19.050	6.35	7.94	1.6													●	●	●	
Тяжелая черновая		CNMM190616-NPR1	19.3	19.050	6.35	7.94	1.6	●	●	●	●									●			



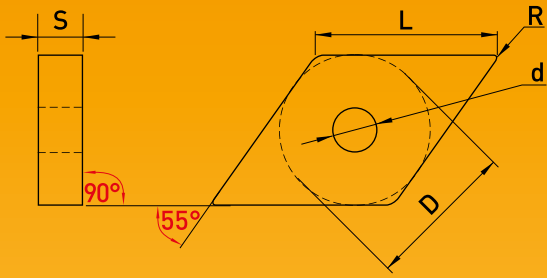

P	★	★	★	★	☆					☆	☆	☆		
M						★	★	★	★					☆
K	☆	☆	☆	☆							★	★	★	
N														★
S							★	★	★	★				★
H											☆			

Обработка	Форморазмер пластины	L мм	D мм	S мм	d мм	R мм	Сплавы																				
							OP25A	OP15	OP25	OP20	OM10	OPM215	OPM25A	OPM25	OK15	OK25	OK20D	ON10	OSM15								
Чистовая		DNMG110404-NPF	11.6	9.525	4.76	3.81	0.4	●	●		●																
		DNMG110408-NPF	11.6	9.525	4.76	3.81	0.8	●	●		●																
		DNMG150404-NPF	15.5	12.700	4.76	5.16	0.4	●	●		●																
		DNMG150408-NPF	15.5	12.700	4.76	5.16	0.8	●	●		●																
		DNMG150604-NPF	15.5	12.700	6.35	5.16	0.4	●	●		●																
		DNMG150608-NPF	15.5	12.700	6.35	5.16	0.8	●	●		●																
		DNMG110404-NSF	11.6	9.525	4.76	3.81	0.4			●	●	●	●	●													
		DNMG150404-NSF	15.5	12.700	4.76	5.16	0.4			●	●	●	●	●													
			DNMG150604-NMF1	15.5	12.700	6.35	5.16	0.4			●	●	●	●	●												
			DNMG150608-NMF1	15.5	12.700	6.35	5.16	0.8			●	●	●	●	●												
Получистовая		DNMG110404-NPM	11.6	9.525	4.76	3.81	0.4	●	●		●																
		DNMG110408-NPM	11.6	9.525	4.76	3.81	0.8	●	●		●																
		DNMG110412-NPM	11.6	9.525	4.76	3.81	1.2	●	●		●																
		DNMG150404-NPM	15.5	12.700	4.76	5.16	0.4	●	●		●																
		DNMG150408-NPM	15.5	12.700	4.76	5.16	0.8	●	●		●																
		DNMG150412-NPM	15.5	12.700	4.76	5.16	1.2	●	●		●																
		DNMG150604-NPM	15.5	12.700	6.35	5.16	0.4	●	●		●																
		DNMG150608-NPM	15.5	12.700	6.35	5.16	0.8	●	●		●																
		DNMG150612-NPM	15.5	12.700	6.35	5.16	1.2	●	●		●																
		DNMG110404-NMM	11.6	9.525	4.76	3.81	0.4		●	●	●	●	●	●													
		DNMG110408-NMM	11.6	9.525	4.76	3.81	0.8		●	●	●	●	●	●													
		DNMG150404-NMM	15.5	12.700	4.76	5.16	0.4		●	●	●	●	●	●													
		DNMG150408-NMM	15.5	12.700	4.76	5.16	0.8		●	●	●	●	●	●													
		DNMG150604-NMM	15.5	12.700	6.35	5.16	0.4		●	●	●	●	●	●													
		DNMG150608-NMM	15.5	12.700	6.35	5.16	0.8		●	●	●	●	●	●													
		DNMG150612-NMM	15.5	12.700	6.35	5.16	1.2		●	●	●	●	●	●													
		DNMG110408-NMF	11.6	9.525	4.76	3.81	0.8					●	●	●													
		DNMG150408-NMF	15.5	12.700	4.76	5.16	0.8					●	●	●													
		DNMG150608-NMF	15.5	12.700	6.35	5.16	0.8					●	●	●													



P	★	★	★	★	☆					☆	☆	☆		
M						★	★	★	★					☆
K	☆	☆	☆	☆							★	★	★	
N														★
S						★	★	★	★					★
H											☆			

Обработка	Форморазмер пластины	L мм	D мм	S мм	d мм	R мм	Сплавы												
							OP25A	OP15	OP25	OP20	OM10	OPM215	OPM25A	OPM25	OK15	OK25	OK20D	ON10	OSM15
Получистовая	 DNMG110408	11.6	9.525	4.76	3.81	0.8		●	●	●					●	●	●		
	DNMG150404	15.5	12.700	4.76	5.16	0.4		●	●	●					●	●	●		
	DNMG150408	15.5	12.700	6.35	5.16	0.8		●	●	●					●	●	●		
	DNMG150412	15.5	12.700	6.35	5.16	1.2		●	●	●					●	●	●		
	DNMG150608	15.5	12.700	6.35	5.16	0.8		●	●	●					●	●	●		
	DNMG150612	15.5	12.700	6.35	5.16	1.2		●	●	●					●	●	●		
Черновая	 DNMG150408-NPR	15.5	12.700	4.76	5.16	0.8	●	●	●	●						●			
	DNMG150412-NPR	15.5	12.700	4.76	5.16	1.2	●	●	●	●						●			
	DNMG150608-NPR	15.5	12.700	6.35	5.16	0.8	●	●	●	●						●			
	DNMG150612-NPR	15.5	12.700	6.35	5.16	1.2	●	●	●	●						●			
	DNMG150616-NPR	15.5	12.700	6.35	5.16	1.6	●	●	●	●						●			
	 DNMA110416	11.6	9.525	4.76	3.81	1.6									●	●	●		
	DNMA150404	15.5	12.700	4.76	5.16	0.4									●	●	●		
	DNMA150408	15.5	12.700	4.76	5.16	0.8									●	●	●		
	DNMA150604	15.5	12.700	6.35	5.16	0.4									●	●	●		
	DNMA150608	15.5	12.700	6.35	5.16	0.8									●	●	●		
	DNMA150612	15.5	12.700	6.35	5.16	1.2									●	●	●		
	DNMA150616	15.5	12.700	6.35	5.16	1.6									●	●	●		

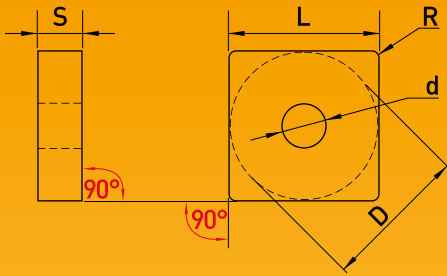



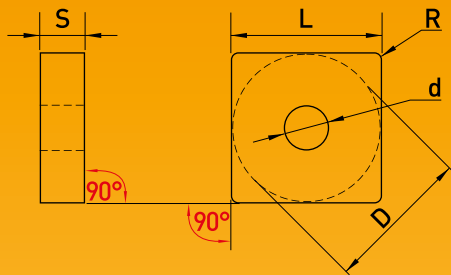

P	★	★	★	★	☆					☆	☆	☆		
M						★	★	★	★					☆
K	☆	☆	☆	☆							★	★	★	
N														★
S							★	★	★	★				★
H											☆			

Обработка	Форморазмер пластины	L мм	D мм	S мм	d мм	R мм	Сплавы												
							OP25A	OP15	OP25	OP20	OM10	OPM215	OPM25A	OPM25	OK15	OK25	OK20D	ON10	OSM15
Чистовая	SNMG120404-NPF	12.700	12.700	4.76	5.16	0.4	●	●	●										
	SNMG120408-NPF	12.700	12.700	4.76	5.16	0.8	●	●	●										
	SNMG120408-NMF1	12.700	12.700	4.76	5.16	0.8					●	●	●	●					
Получистовая	SNMG120404-NPM	12.700	12.700	4.76	5.16	0.4	●	●	●								●		
	SNMG120408-NPM	12.700	12.700	4.76	5.16	0.8	●	●	●								●		
	SNMG120412-NPM	12.700	12.700	4.76	5.16	1.2	●	●	●								●		
	SNMG150608-NPM	15.875	15.875	6.35	6.35	0.8	●	●	●								●		
	SNMG150612-NPM	15.875	15.875	6.35	6.35	1.2	●	●	●								●		
	SNMG190612-NPM	19.050	19.050	6.35	7.94	1.2	●	●	●								●		
	SNMG120404-NMM	12.700	12.700	4.76	5.16	0.4		●	●	●	●	●	●						
	SNMG120408-NMM	12.700	12.700	4.76	5.16	0.8		●	●	●	●	●	●						
	SNMG120412-NMM	12.700	12.700	4.76	5.16	1.2		●	●	●	●	●	●						
	SNMG150608-NMM	15.875	15.875	6.35	6.35	0.8		●	●	●	●	●	●						
	SNMG120408-NMF	12.700	12.700	4.76	5.16	0.8					●	●	●	●					
SNMG120408-NSO	12.700	12.700	4.76	5.16	0.8													●	



P	★	★	★	★	☆					☆	☆	☆		
M						★	★	★	★					☆
K	☆	☆	☆	☆							★	★	★	
N														★
S							★	★	★	★				★
H											☆			

Обработка	Форморазмер пластины	L мм	D мм	S мм	d мм	R мм	Сплавы												
							OP25A	OP15	OP25	OP20	OM10	OPM215	OPM25A	OPM25	OK15	OK25	OK20D	ON10	OSM15
Получистовая	 SNMG090304	9.525	9.525	3.180	3.81	0.4			●	●					●	●	●		
	SNMG090308	9.525	9.525	3.180	3.81	0.8			●	●					●	●	●		
	SNMG120404	12.700	12.700	4.760	5.16	0.4			●	●					●	●	●		
	SNMG120408	12.700	12.700	4.760	5.16	0.8			●	●					●	●	●		
	SNMG120412	12.700	12.700	4.760	5.16	1.2			●	●					●	●	●		
	SNMG120416	12.700	12.700	4.760	5.16	1.6			●	●					●	●	●		
	SNMG150608	15.875	15.875	6.350	6.35	0.8			●	●					●	●	●		
	SNMG150612	15.875	15.875	6.350	6.35	1.2			●	●					●	●	●		
	SNMG190612	19.050	19.050	6.350	7.94	1.2	●	●	●	●						●			
	SNMG190616	19.050	19.050	6.350	7.94	1.6	●	●	●	●						●			
	SNMG250724	25.400	25.400	7.940	9.12	2.4	●	●	●	●						●			
SNMG250924	25.400	25.400	9.525	9.12	2.4	●	●	●	●						●				
Черновая	 SNMG120408-NPR	12.700	12.700	4.760	5.16	0.8	●	●	●	●						●			
	SNMG120412-NPR	12.700	12.700	4.760	5.16	1.2	●	●	●	●						●			
	SNMG150608-NPR	15.875	15.875	6.350	6.35	0.8	●	●	●	●						●			
	SNMG150612-NPR	15.875	15.875	6.350	6.35	1.2	●	●	●	●						●			
	SNMG190612-NPR	19.050	19.050	6.350	7.94	1.2	●	●	●	●						●			
	SNMG190616-NPR	19.050	19.050	6.350	7.94	1.6	●	●	●	●						●			
	 SNMM190624-NPR1	19.050	19.050	6.350	7.94	2.4	●	●	●	●						●			
	SNMM250924-NPR1	25.400	25.400	9.525	9.12	2.4	●	●	●	●						●			
	 SNMA120408	12.700	12.700	4.760	5.16	0.8										●	●	●	
	SNMA120412	12.700	12.700	4.760	5.16	1.2										●	●	●	
	SNMA120416	12.700	12.700	4.760	5.16	1.6										●	●	●	
	SNMA150608	15.875	15.875	6.350	6.35	0.8										●	●	●	
	SNMA150612	15.875	15.875	6.350	6.35	1.2										●	●	●	
SNMA190612	19.050	19.050	6.350	7.94	1.2											●	●		
SNMA190616	19.050	19.050	6.350	7.94	1.6											●	●		

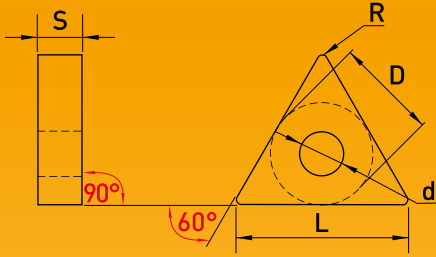

P	★	★	★	★	☆					☆	☆	☆		
M					★	★	★	★						☆
K	☆	☆	☆	☆							★	★	★	
N														★
S						★	★	★	★					★
H											☆			

Обработка	Форморазмер пластины	L мм	D мм	S мм	d мм	R мм	Сплавы														
							OP25A	OP15	OP25	OP20	OM10	OPM215	OPM25A	OPM25	OK15	OK25	OK20D	ON10	OSM15		
Чистовая		TNMG160404-NPF	16.5	9.525	4.76	3.81	0.4	●	●	●											
		TNMG160408-NPF	16.5	9.525	4.76	3.81	0.8	●	●	●											
		TNMG160404-NMF1	16.5	9.525	4.76	3.81	0.4				●	●	●	●							
		TNMG160408-NMF1	16.5	9.525	4.76	3.81	0.8				●	●	●	●							
		TNMG160404-NSF	16.5	9.525	4.76	3.81	0.4				●	●	●	●							
Получистовая		TNMG160404-NPM	16.5	9.525	4.76	3.81	0.4	●	●	●									●		
		TNMG160408-NPM	16.5	9.525	4.76	3.81	0.8	●	●	●									●		
		TNMG160412-NPM	16.5	9.525	4.76	3.81	1.2	●	●	●									●		
		TNMG220404-NPM	22.0	12.700	4.76	5.16	0.4	●	●	●									●		
		TNMG220408-NPM	22.0	12.700	4.76	5.16	0.8	●	●	●									●		
		TNMG220412-NPM	22.0	12.700	4.76	5.16	1.2	●	●	●									●		
		TNMG160404-NMM	16.5	9.525	4.76	3.81	0.4		●	●	●	●	●	●							
		TNMG160408-NMM	16.5	9.525	4.76	3.81	0.8		●	●	●	●	●	●							
		TNMG160412-NMM	16.5	9.525	4.76	3.81	1.2		●	●	●	●	●	●							
		TNMG220404-NMM	22.0	12.700	4.76	5.16	0.4		●	●	●	●	●	●							
		TNMG220408-NMM	22.0	12.700	4.76	5.16	0.8		●	●	●	●	●	●							
		TNMG220412-NMM	22.0	12.700	4.76	5.16	1.2		●	●	●	●	●	●							
		TNMG160404-NMF	16.5	9.525	4.76	3.81	0.4				●	●	●	●							
		TNMG160408-NMF	16.5	9.525	4.76	3.81	0.8				●	●	●	●							
		TNMG160412-NMF	16.5	9.525	4.76	3.81	1.2				●	●	●	●							

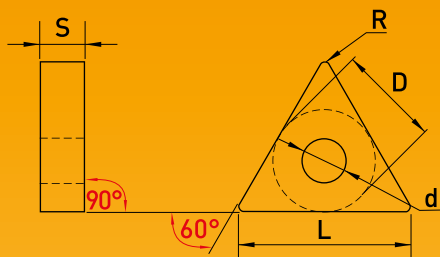

P	★	★	★	★	☆					☆	☆	☆		
M					★	★	★	★						☆
K	☆	☆	☆	☆						★	★	★		
N														★
S						★	★	★	★					★
H											☆			

Обработка	Форморазмер пластины	L мм	D мм	S мм	d мм	R мм	Сплавы															
							OP25A	OP15	OP25	OP20	OM10	OPM215	OPM25A	OPM25	OK15	OK25	OK20D	ON10	OSM15			
Получистовая		TNMG160408	16.5	9.525	4.76	3.81	0.8	●	●	●	●						●	●	●			
		TNMG160412	16.5	9.525	4.76	3.81	1.2	●	●	●	●							●	●	●		
		TNMG220404	22.0	12.700	4.76	5.16	0.4	●	●	●	●							●	●	●		
		TNMG220408	22.0	12.700	4.76	5.16	0.8	●	●	●	●							●	●	●		
		TNMG220412	22.0	12.700	4.76	5.16	1.2	●	●	●	●							●	●	●		
		TNMG220416	22.0	12.700	4.76	5.16	1.6	●	●	●	●							●	●	●		
Черновая		TNMG160404-NPR	16.5	9.525	4.76	3.81	0.4	●	●	●	●							●				
		TNMG160408-NPR	16.5	9.525	4.76	3.81	0.8	●	●	●	●							●				
		TNMG160412-NPR	16.5	9.525	4.76	3.81	1.2	●	●	●	●							●				
		TNMG160416-NPR	16.5	9.525	4.76	3.81	1.6	●	●	●	●							●				
		TNMG220408-NPR	22.0	12.700	4.76	5.16	0.8	●	●	●	●							●				
		TNMG220412-NPR	22.0	12.700	4.76	5.16	1.2	●	●	●	●							●				
		TNMG220416-NPR	22.0	12.700	4.76	5.16	1.6	●	●	●	●							●				
	TNMG270612-NPR	27.5	15.875	6.35	6.35	1.2	●	●	●	●							●					
		TNMA160404	16.5	9.525	4.76	3.81	0.4											●	●	●		
		TNMA160408	16.5	9.525	4.76	3.81	0.8											●	●	●		
TNMA160412		16.5	9.525	4.76	3.81	1.2											●	●	●			
TNMA160416		16.5	9.525	4.76	3.81	1.6											●	●	●			
TNMA220408		22.0	12.700	4.76	5.16	0.8											●	●	●			
TNMA220412		22.0	12.700	4.76	5.16	1.2											●	●	●			
TNMA220416		22.0	12.700	4.76	5.16	1.6											●	●	●			

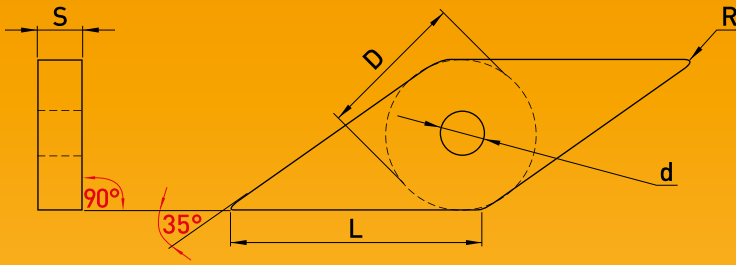

P	★	★	★	★	☆				☆	☆	☆				
M						★	★	★	★						☆
K	☆	☆	☆	☆								★	★	★	
N															★
S						★	★	★	★						★
H												☆			

Обработка	Форморазмер пластины	L мм	D мм	S мм	d мм	R мм	Сплавы																			
							OP25A	OP15	OP25	OP20	OM10	OPM215	OPM25A	OPM25	OK15	OK25	OK20D	ON10	OSM15							
Чистовая	VNMG160404-NPF	16.6	9.525	4.76	3.81	0.4		●	●	●																
	VNMG160408-NPF	16.6	9.525	4.76	3.81	0.8		●	●	●																
	VNMG160404-NSF	16.6	9.525	4.76	3.81	0.4					●	●	●	●												
Получистовая	VNMG160404-NPM	16.6	9.525	4.76	3.81	0.4		●	●	●											●					
	VNMG160408-NPM	16.6	9.525	4.76	3.81	0.8		●	●	●											●					
	VNMG160412-NPM	16.6	9.525	4.76	3.81	1.2		●	●	●											●					
	VNMG160404-NMM	16.6	9.525	4.76	3.81	0.4			●	●	●	●	●	●												
	VNMG160408-NMM	16.6	9.525	4.76	3.81	0.8			●	●	●	●	●	●												
	VNMG160408-NMF	16.6	9.525	4.76	3.81	0.8					●	●	●	●												
Черновая	VNMG160404	16.6	9.525	4.76	3.81	0.4	●	●												●	●	●				
	VNMG160408	16.6	9.525	4.76	3.81	0.8	●	●												●	●	●				
	VNMG160408-NPR	16.6	9.525	4.76	3.81	0.4	●	●	●	●											●					
	VNMG160412-NPR	16.6	9.525	4.76	3.81	0.8	●	●	●	●											●					
	VNMA160404	16.6	9.525	4.76	3.81	0.4															●	●	●			
	VNMA160408	16.6	9.525	4.76	3.81	0.8															●	●	●			

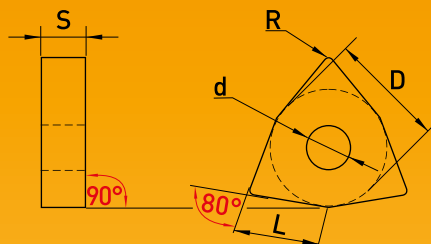

P	★	★	★	★	☆					☆	☆	☆		
M						★	★	★	★					☆
K	☆	☆	☆	☆							★	★	★	
N														★
S							★	★	★	★				★
H											☆			

Обработка	Форморазмер пластины	L мм	D мм	S мм	d мм	R мм	Сплавы																				
							OP25A	OP15	OP25	OP20	OM10	OPM215	OPM25A	OPM25	OK15	OK25	OK20D	ON10	OSM15								
Чистовая		WNMG060404-NPF	6.5	9.525	4.76	3.81	0.4		●	●	●																
		WNMG060408-NPF	6.5	9.525	4.76	3.81	0.8		●	●	●																
		WNMG080404-NPF	8.7	12.700	4.76	5.16	0.4		●	●	●																
		WNMG080408-NPF	8.7	12.700	4.76	5.16	0.8		●	●	●																
		WNMG060408-NMF1	6.5	9.525	4.76	3.81	0.8					●	●	●	●												
		WNMG080404-NMF1	8.7	12.700	4.76	5.16	0.4					●	●	●	●												
		WNMG080408-NMF1	8.7	12.700	4.76	5.16	0.8					●	●	●	●												
			WNMG060304-NSF	6.5	9.525	3.18	3.81	0.4					●	●	●	●											
			WNMG060404-NSF	6.5	9.525	4.76	3.81	0.4					●	●	●	●											
			WNMG080404-NSF	8.7	12.700	4.76	5.16	0.4					●	●	●	●											
	Получистовая		WNMG060408-NPM	6.5	9.525	4.76	3.81	0.8		●	●	●															
			WNMG080404-NPM	8.7	12.700	4.76	5.16	0.4		●	●	●															
WNMG080408-NPM			8.7	12.700	4.76	5.16	0.8		●	●	●																
WNMG080412-NPM			8.7	12.700	4.76	5.16	1.2		●	●	●																
		WNMG060408-NMM	6.5	9.525	4.76	3.81	0.8			●		●	●	●	●												
		WNMG060412-NMM	6.5	9.525	4.76	3.81	1.2			●		●	●	●	●												
		WNMG080404-NMM	8.7	12.700	4.76	5.16	0.4			●		●	●	●	●												
		WNMG080408-NMM	8.7	12.700	4.76	5.16	0.8			●		●	●	●	●												
		WNMG080412-NMM	8.7	12.700	4.76	5.16	1.2			●		●	●	●	●												
			WNMG060408-NMF	6.5	9.525	4.76	3.81	0.8					●	●	●	●											
			WNMG080408-NMF	8.7	12.700	4.76	5.16	0.8					●	●	●	●											
			WNMG080412-NMF	8.7	12.700	4.76	5.16	1.2					●	●	●	●											
			WNMG080404	8.7	12.700	4.76	5.16	0.4	●	●	●	●									●	●	●				
		WNMG080408	8.7	12.700	4.76	5.16	0.8	●	●	●	●									●	●	●					
		WNMG080412	8.7	12.700	4.76	5.16	1.2	●	●	●	●									●	●	●					
Черновая			WNMG080408-NPR	8.7	12.700	4.76	5.16	0.8	●	●	●	●										●					
			WNMG080412-NPR	8.7	12.700	4.76	5.16	1.2	●	●	●	●											●				
			WNMA060404	6.5	9.525	4.76	3.81	0.4															●	●	●		
	WNMA060412		6.5	9.525	4.76	3.81	1.2															●	●	●			
	WNMA080408		8.7	12.700	4.76	5.16	0.8															●	●	●			
	WNMA080412		8.7	12.700	4.76	5.16	1.2															●	●	●			
	WNMA080416		8.7	12.700	4.76	5.16	1.6															●	●	●			

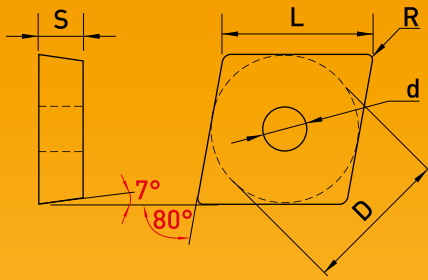

P	★	★	★	★	☆					☆	☆	☆		
M					★	★	★	★						☆
K	☆	☆	☆	☆							★	★	★	
N														★
S						★	★	★	★					★
H											☆			

Обработка	Форморазмер пластины	L мм	D мм	S мм	d мм	R мм	Сплавы																			
							OP25A	OP15	OP25	OP20	OM10	OPM215	OPM25A	OPM25	OK15	OK25	OK20D	ON10	OSM15							
Чистовая		CCMT060202-PTF	6.4	6.350	2.38	2.8	0.2		●	●	●			●	●											
		CCMT060204-PTF	6.4	6.350	2.38	2.8	0.4		●	●	●			●	●											
		CCMT060208-PTF	6.4	6.350	2.38	2.8	0.8		●	●	●			●	●											
		CCMT09T304-PTF	9.7	9.525	3.97	4.4	0.4		●	●	●			●	●											
		CCMT09T308-PTF	9.7	9.525	3.97	4.4	0.8		●	●	●			●	●											
		CCMT120404-PTF	12.9	12.700	4.76	5.5	0.4		●	●	●			●	●											
		CCMT120408-PTF	12.9	12.700	4.76	5.5	0.8		●	●	●			●	●											
		CCMT060202-CSF	6.4	6.350	2.38	2.8	0.2						●	●	●											
		CCMT060204-CSF	6.4	6.350	2.38	2.8	0.4						●	●	●											
		CCMT09T304-CSF	9.7	9.525	3.97	4.4	0.4						●	●	●											
		CCMT09T308-CSF	12.9	12.700	4.76	5.5	0.8						●	●	●											
		CCMT120404-CSF	12.9	12.700	4.76	5.5	0.4						●	●	●											
		CCGX060202-AL	6.4	6.350	2.38	2.8	0.2																		●	
		CCGX060204-AL	6.4	6.350	2.38	2.8	0.4																		●	
CCGX09T302-AL		9.7	9.525	3.97	4.4	0.2																		●		
CCGX09T304-AL		9.7	9.525	3.97	4.4	0.4																		●		
CCGX09T308-AL		9.7	9.525	3.97	4.4	0.8																		●		
CCGX120404-AL		12.9	12.700	4.76	5.5	0.4																		●		
CCGX120408-AL		12.9	12.700	4.76	5.5	0.8																		●		
Получистовая			CCMT060204-PTM	6.4	6.350	2.38	2.8	0.4		●	●	●			●	●			●							
	CCMT060208-PTM		6.4	6.350	2.38	2.8	0.8		●	●	●			●	●			●								
	CCMT09T304-PTM		9.7	9.525	3.97	4.4	0.4		●	●	●			●	●			●								
	CCMT09T308-PTM		9.7	9.525	3.97	4.4	0.8		●	●	●			●	●			●								
	CCMT120404-PTM		12.9	12.700	4.76	5.5	0.4		●	●	●			●	●			●								
	CCMT120408-PTM		12.9	12.700	4.76	5.5	0.8		●	●	●			●	●			●								
		CCMT060204-PGM	6.4	6.350	2.38	2.8	0.4		●	●	●			●	●											
		CCMT060208-PGM	6.4	6.350	2.38	2.8	0.8		●	●	●			●	●											
		CCMT09T304-PGM	9.7	9.525	3.97	4.4	0.4		●	●	●			●	●											
		CCMT09T308-PGM	9.7	9.525	3.97	4.4	0.8		●	●	●			●	●											
		CCMT120404-PGM	12.9	12.700	4.76	5.5	0.4		●	●	●			●	●											
		CCMT120408-PGM	12.9	12.700	4.76	5.5	0.8		●	●	●			●	●											
			CCMT060208-PTR	6.4	6.350	2.38	2.8	0.8		●	●	●								●	●					
			CCMT09T304-PTR	9.7	9.525	3.97	4.4	0.4		●	●	●								●	●					
CCMT09T308-PTR	9.7		9.525	3.97	4.4	0.8		●	●	●								●	●							
CCMT120408-PTR	12.9		12.700	4.76	5.5	0.8		●	●	●								●	●							
CCMT120412-PTR	12.9		12.700	4.76	5.5	1.2		●	●	●								●	●							

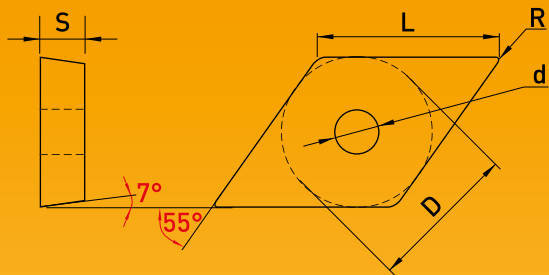

P	★	★	★	★	☆					☆	☆	☆		
M						★	★	★	★					☆
K	☆	☆	☆	☆							★	★	★	
N														★
S							★	★	★	★				★
H											☆			

Обработка	Форморазмер пластины	L мм	D мм	S мм	d мм	R мм	Сплавы												
							OP25A	OP15	OP25	OP20	OM10	OPM215	OPM25A	OPM25	OK15	OK25	OK20D	ON10	OSM15
Чистовая		DCMT070204-PTF	7.8	6.350	2.38	2.8	0.4		●	●	●			●	●				
		DCMT070208-PTF	7.8	6.350	2.38	2.8	0.8		●	●	●			●	●				
		DCMT11T302-PTF	11.6	9.525	3.97	4.4	0.2		●	●	●			●	●				
		DCMT11T304-PTF	11.6	9.525	3.97	4.4	0.4		●	●	●			●	●				
		DCMT11T308-PTF	11.6	9.525	3.97	4.4	0.8		●	●	●			●	●				
		DCGX070202-AL	7.8	6.350	2.38	2.8	0.2												●
		DCGX070204-AL	7.8	6.350	2.38	2.8	0.4												●
		DCGX11T302-AL	11.6	9.525	3.97	4.4	0.2												●
Получистовая		DCGX11T304-AL	11.6	9.525	3.97	4.4	0.4												●
		DCGX11T308-AL	11.6	9.525	3.97	4.4	0.8												●
		DCMT070204-PTM	7.8	6.350	2.38	2.8	0.4		●	●	●			●	●		●		
		DCMT070208-PTM	7.8	6.350	2.38	2.8	0.8		●	●	●			●	●		●		
		DCMT11T304-PTM	11.6	9.525	3.97	4.4	0.4		●	●	●			●	●		●		
		DCMT11T308-PTM	11.6	9.525	3.97	4.4	0.8		●	●	●			●	●		●		
		DCMT070204-PGM	7.8	6.350	2.38	2.8	0.4		●	●	●			●	●				
		DCMT070208-PGM	7.8	6.350	2.38	2.8	0.8		●	●	●			●	●				
Черновая		DCMT11T304-PGM	11.6	9.525	3.97	4.4	0.4		●	●	●			●	●				
		DCMT11T308-PGM	11.6	9.525	3.97	4.4	0.8		●	●	●			●	●				
		DCMT11T304-PTR	11.6	9.525	3.97	4.4	0.4		●	●	●						●	●	
		DCMT11T308-PTR	11.6	9.525	3.97	4.4	0.8		●	●	●						●	●	
	DCMT11T312-PTR	11.6	9.525	3.97	4.4	1.2		●	●	●						●	●		

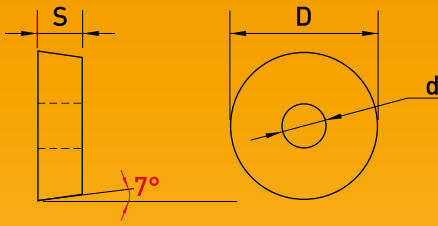

P	★	★	★	★	☆					☆	☆	☆		
M					★	★	★	★						☆
K	☆	☆	☆	☆						★	★	★		
N													★	
S					★	★	★	★						★
H										☆				

Обработка	Форморазмер пластины		L мм	D мм	S мм	d мм	R мм	Сплавы																	
								OP25A	OP15	OP25	OP20	OM10	OPM215	OPM25A	OPM25	OK15	OK25	OK20D	ON10	OSM15					
П/ч.		RCMT0803M0	8	8	3.18	3.4		●		●	●	●													
		RCMT1606M0	16	16	6.35	5.5		●		●	●	●													
П/ч. / Черновая		RCMX0803M0	8	8	3.18	3.4		●		●	●	●							●						
		RCMX1003M0	10	10	3.18	3.6		●		●	●	●							●						
		RCMX1204M0	12	12	4.76	4.4		●		●	●	●							●						
		RCMX1606M0	16	16	6.35	5.5		●		●	●	●							●						
		RCMX2006M0	20	20	6.35	6.5		●		●	●	●							●						
		RCMX2507M0	25	25	7.94	7.2		●		●	●	●							●						
		RCMX3209M0	32	32	9.52	9.5		●		●	●	●					●								

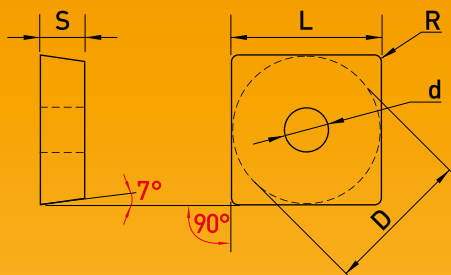

P	★	★	★	★	☆				☆	☆	☆			
M						★	★	★	★					☆
K	☆	☆	☆	☆							★	★	★	
N														★
S						★	★	★	★					★
H											☆			

Обработка	Форморазмер пластины	L мм	D мм	S мм	d мм	R мм	Сплавы																	
							OP25A	OP15	OP25	OP20	OM10	OPM215	OPM25A	OPM25	OK15	OK25	OK20D	ON10	OSM15					
Чистовая		SCMT09T304-PTF	9.525	9.525	3.97	4.4	0.4		●	●	●				●	●								
		SCMT09T308-PTF	9.525	9.525	3.97	4.4	0.8		●	●	●				●	●								
		SCMT120404-PTF	12.700	12.700	4.76	5.5	0.4		●	●	●				●	●								
		SCGX09T304-Al	9.525	9.525	3.97	4.4	0.4																	●
		SCGX09T308-Al	9.525	9.525	3.97	4.4	0.8																	●
		SCGX120408-Al	12.700	12.700	4.76	5.5	0.8																	●
Получистовая		SCMT09T304-PTM	9.525	9.525	3.97	4.4	0.4		●	●	●				●	●		●						
		SCMT09T308-PTM	9.525	9.525	3.97	4.4	0.8		●	●	●				●	●		●						
		SCMT120404-PTM	12.700	12.700	4.76	5.5	0.4		●	●	●				●	●		●						
		SCMT120408-PTM	12.700	12.700	4.76	5.5	0.8		●	●	●				●	●		●						
		SCMT120412-PTM	12.700	12.700	4.76	5.5	1.2		●	●	●				●	●		●						
		SCMT09T304-PGM	9.525	9.525	3.97	4.4	0.4		●	●	●				●	●								
		SCMT09T308-PGM	9.525	9.525	3.97	4.4	0.8		●	●	●				●	●								
Черновая		SCMT09T304-PTR	9.525	9.525	3.97	4.4	0.4		●		●							●	●					
		SCMT09T308-PTR	9.525	9.525	3.97	4.4	0.8		●		●							●	●					
		SCMT120404-PTR	12.700	12.700	4.76	5.5	0.4		●		●							●	●					
		SCMT120408-PTR	12.700	12.700	4.76	5.5	0.8		●		●							●	●					
		SCMT120412-PTR	12.700	12.700	4.76	5.5	1.2		●		●							●	●					

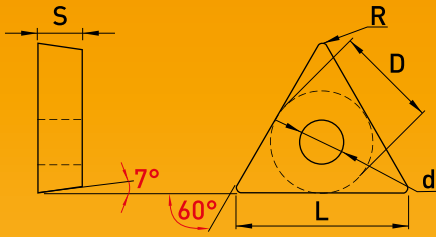

P	★	★	★	★	☆					☆	☆	☆		
M						★	★	★	★					☆
K	☆	☆	☆	☆							★	★	★	
N														★
S							★	★	★	★				★
H											☆			

Обработка	Форморазмер пластины	L мм	D мм	S мм	d мм	R мм	Сплавы											
							OP25A	OP15	OP25	OP20	OM10	OPM215	OPM25A	OPM25	OK15	OK25	OK20D	ON10
Чистовая		TCMT110202-PTF	11.0	6.350	2.38	2.8	0.2	●	●	●			●	●				
		TCMT110204-PTF	11.0	6.350	2.38	2.8	0.4	●	●	●			●	●				
		TCMT16T304-PTF	16.5	9.525	3.97	4.4	0.4	●	●	●			●	●				
		TCMT16T308-PTF	16.5	9.525	3.97	4.4	0.8	●	●	●			●	●				
		TCGX090204-AL	9.6	5.560	2.38	2.5	0.4											●
		TCGX110202-AL	11.0	6.350	2.38	2.8	0.2											●
		TCGX110204-AL	11.0	6.350	2.38	2.8	0.4											●
		TCGX16T304-AL	16.5	9.525	3.97	4.4	0.4											●
Получистовая		TCMT090204-PTM	9.6	5.560	2.38	2.5	0.4	●	●	●			●	●		●		
		TCMT090208-PTM	9.6	5.560	2.38	2.5	0.8	●	●	●			●	●		●		
		TCMT110204-PTM	11.0	6.350	2.38	2.8	0.4	●	●	●			●	●		●		
		TCMT110208-PTM	11.0	6.350	2.38	2.8	0.8	●	●	●			●	●		●		
		TCMT16T304-PTM	16.5	9.525	3.97	4.4	0.4	●	●	●			●	●		●		
		TCMT16T308-PTM	16.5	9.525	3.97	4.4	0.8	●	●	●			●	●		●		
		TCMT16T312-PTM	16.5	9.525	3.97	4.4	1.2	●	●	●			●	●		●		
		TCMT110204-PGM	11.0	6.350	2.38	2.8	0.4	●	●	●			●	●				
		TCMT110208-PGM	11.0	6.350	2.38	2.8	0.8	●	●	●			●	●				
		TCMT16T304-PGM	16.5	9.525	3.97	4.4	0.4	●	●	●			●	●				
		TCMT16T308-PGM	16.5	9.525	3.97	4.4	0.8	●	●	●			●	●				
		TCMT16T304-PTR	16.5	9.525	3.97	4.4	0.4	●	●	●						●	●	
Черновая		TCMT16T308-PTR	16.5	9.525	3.97	4.4	0.8	●	●	●					●	●		
		TCMT16T312-PTR	16.5	9.525	3.97	4.4	1.2	●	●	●					●	●		
		TCMT220408-PTR	22.0	12.700	4.76	5.5	0.8	●	●	●					●	●		

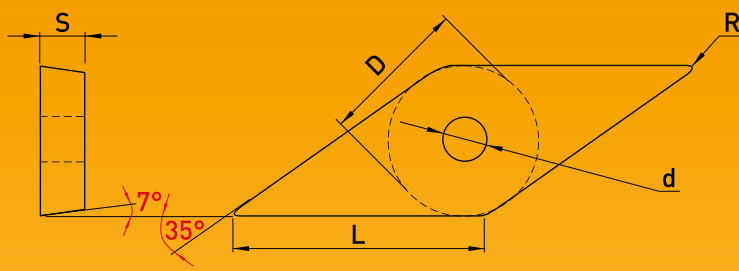





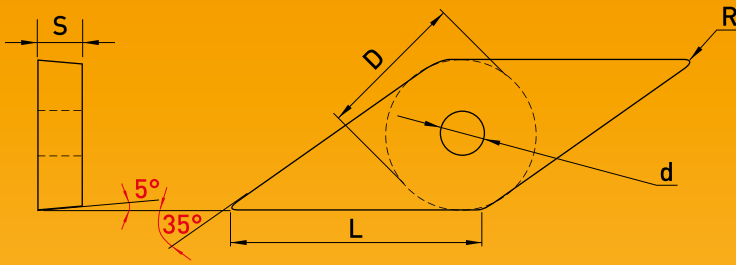



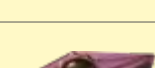
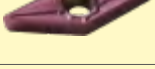

P	★	★	★	★	★	☆					☆	☆	☆		
M					★	★	★	★	★						☆
K	☆	☆	☆	☆	★						★	★	★		
N					★										★
S							★	★	★	★					★
H											☆				

Обработка	Форморазмер пластины	L мм	D мм	S мм	d мм	R мм	Сплавы																		
							OP25A	OP15	OP25	OP20	OM26	OM10	OPM215	OPM25A	OPM25	OK15	OK25	OK20D	ON10	OSM15					
Чистовая		VCMT110302-PTF	11.0	6.350	3.18	2.8	0.2		●	●	●				●	●									
		VCMT110304-PTF	11.0	6.350	3.18	2.8	0.4		●	●	●				●	●									
		VCMT160404-PTF	16.5	9.525	4.76	4.4	0.4		●	●	●				●	●									
		VCGX110302-AL	11.0	6.350	3.18	2.8	0.2																	●	
		VCGX110304-AL	11.0	6.350	3.18	2.8	0.4																	●	
		VCGX160402-AL	16.5	9.525	4.76	4.4	0.2																	●	
		VCGX160404-AL	16.5	9.525	4.76	4.4	0.4																	●	
		VCGX160408-AL	16.5	9.525	4.76	4.4	0.8																	●	
Получистовая		VCMT160404-PTM	16.5	9.525	4.76	4.4	0.4		●	●	●				●	●									
		VCMT160408-PTM	16.5	9.525	4.76	4.4	0.8		●	●	●				●	●									
		VCMT160408-PSO	16.5	9.525	4.76	4.4	0.8																		●

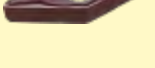
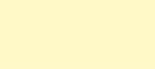

P	★	★	★	★	★	☆				☆	☆	☆		
M						★	★	★	★	★				☆
K	☆	☆	☆	☆	★						★	★	★	
N					★									★
S							★	★	★	★				★
H											☆			

Обработка	Форморазмер пластины	L мм	D мм	S мм	d мм	R мм	Сплавы														
							OP25A	OP15	OP25	OP20	OM26	OM10	OPM215	OPM25A	OPM25	OK15	OK25	OK20D	ON10	OSM15	
Чистовая	 VBMT160404-PTF	16.5	9.525	4.76	4.4	0.4	●	●	●				●	●							
	 VBMT160408-PTF	16.5	9.525	4.76	4.4	0.8	●	●	●				●	●							
Получистовая	 VBMT110304-PTM	11.0	6.350	3.18	2.8	0.4	●	●	●				●	●		●					
	 VBMT110308-PTM	11.0	6.350	3.18	2.8	0.8	●	●	●				●	●		●					
	 VBMT160404-PTM	16.5	9.525	4.76	4.4	0.4	●	●	●				●	●		●					
	 VBMT160408-PTM	16.5	9.525	4.76	4.4	0.8	●	●	●				●	●		●					
	 VBMT160412-PTM	16.5	9.525	4.76	4.4	1.2	●	●	●				●	●		●					
	 VBMT160404-PSO	16.5	9.525	4.76	4.4	0.4	●	●	●				●	●		●					
	 VBMT160408-PSO	16.5	9.525	4.76	4.4	0.8	●	●	●				●	●		●					
Черновая	 VBMT160404-PGM	16.5	9.525	4.76	4.4	0.4	●	●	●				●	●						●	
	 VBMT160408-PGM	16.5	9.525	4.76	4.4	0.8	●	●	●				●	●						●	
	 VBMT160404-PTR	16.5	9.525	4.76	4.4	0.4	●	●	●							●	●				
	 VBMT160408-PTR	16.5	9.525	4.76	4.4	0.8	●	●	●						●	●					
	 VBMT160412-PTR	16.5	9.525	4.76	4.4	1.2	●	●	●						●	●					

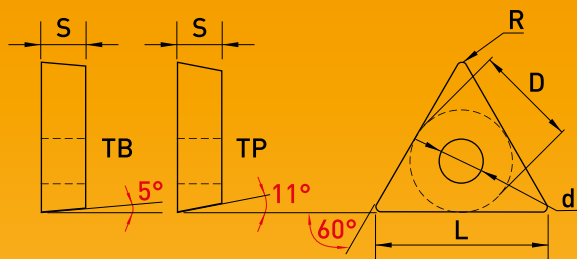

P	★	★	★	★	★	☆				☆	☆	☆		
M						★	★	★	★					☆
K	☆	☆	☆	☆	★					★	★	★		
N					★								★	
S							★	★	★	★				★
H											☆			

Обработка	Форморазмер пластины	L мм	D мм	S мм	d мм	R мм	Сплавы																			
							OP25A	OP15	OP25	OP20	OM26	OM10	OPM215	OPM25A	OPM25	OK15	OK25	OK20D	ON10	OSM15						
Чистовая	TBGH060202L	6.4	3.97	2.38	2.30	0.2					●	●														
	TBGH060202R	6.4	3.97	2.38	2.30	0.2					●	●														
	TBGH060204L	6.4	3.97	2.38	2.30	0.4					●	●														
	TBGH060204R	6.4	3.97	2.38	2.30	0.4					●	●														
	TPGH080202L	8.2	4.76	2.38	2.40	0.2					●	●														
	TPGH080204L	8.2	4.76	2.38	2.40	0.4					●	●														
	TPGH090202L	9.6	5.56	2.38	2.80	0.2					●	●														
	TPGH090204L	9.6	5.56	2.38	2.80	0.4					●	●														
	TPGH110302L	11.0	6.35	3.18	3.18	0.2					●	●														
	TPGH110304L	11.0	6.35	3.18	3.18	0.4					●	●														
	TPGH11T302L	11.0	6.35	3.97	3.18	0.2					●	●														
	TPGH11T302R	11.0	6.35	3.97	3.18	0.2					●	●														
	TPGH11T304L	11.0	6.35	3.97	3.18	0.4					●	●														
	TPGH11T304R	11.0	6.35	3.97	3.18	0.4					●	●														

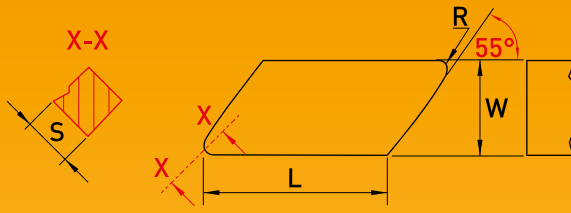

P	★	★	★	☆			☆	☆	☆
M				★	★	★			
K	☆	☆	☆				★	★	★
N									
S				★	★	★			
H							☆		

Обработка	Форморазмер пластины	L мм	W мм	S мм	R мм	Сплавы											
						OP25A	OP15	OP25	OM10	OPM25A	OPM215	OK15	OK25	OK20D			
П/ч.	 KNUX160405L11	16.2	9.525	4.76	0.5	●			●		●						
	KNUX160405R11	16.2	9.525	4.76	0.5	●			●		●						



СВН ПЛАСТИНЫ

СМЕННЫЕ ТВЕРДОСПЛАВНЫЕ ДЛЯ ТОКАРНОЙ ОБРАБОТКИ

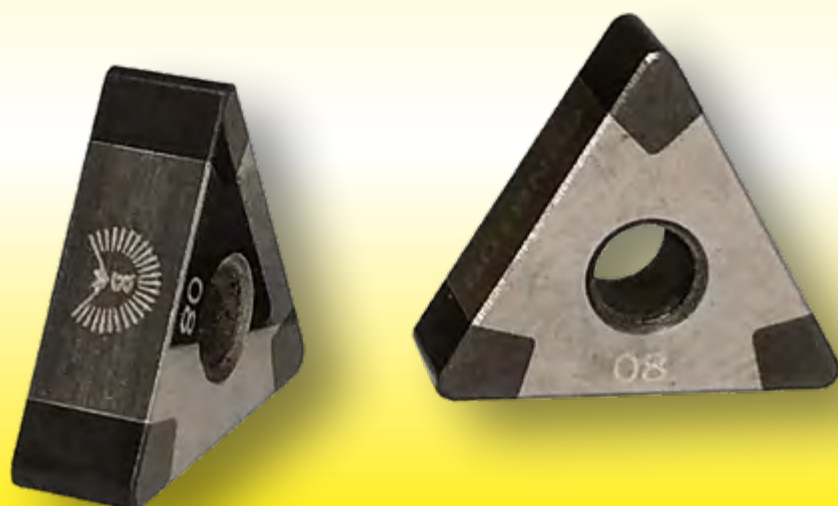

РАЗДЕЛ 2

1. Форма пластины	2. Задний угол пластины	3. Класс точности	4. Исполнение пластины	5. Размер пластины	6. Толщина пластины
D	N	G	A	15	06

Обозначение	Угол	Форма пластин
A	85°	
B	82°	
C	80°	
D	55°	
E	75°	
K	55°	
M	86°	
N	55°	
V	35°	
H	120°	
L	90°	
O	135°	
P	108°	
R	—	
S	90°	
T	60°	
W	80°	

Задний угол пластин	
A 3°	
B 5°	
C 7°	
D 15°	
E 20°	
F 25°	
G 30°	
N 0°	
P 11°	

Класс точности	Поля допуска		
	D	B	S
C	±0,025	±0,013	±0,025
H	±0,013	±0,013	±0,025
E	±0,025	±0,025	±0,025
G	±0,025	±0,025	±0,013
M			±0,013
U			±0,013

D	Поля допуска на размер D			
	Допуск класс M		Допуск класс U	
	Ф о р м ы			
	S, T, C, R, W	D	V	S, T, C
3,97	0,05	—	—	—
4,76	0,05	—	—	0,08
5,56	0,05	0,05	0,05	0,08
6,35	0,05	0,05	0,05	0,08
7,94	0,05	0,05	0,05	0,08
9,52	0,05	0,05	0,05	0,08
11,11	0,08	0,08	0,08	0,13
12,70	0,08	0,08	0,08	0,13
14,29	0,08	0,08	0,08	0,13
15,88	0,10	0,10	0,10	0,18
17,46	0,10	0,10	0,10	0,18
19,05	0,10	0,10	0,10	0,18
22,22	0,13	—	—	0,25
25,40	0,13	—	—	0,25
31,75	0,15	—	—	0,25

D	Поля допуска на размер B			
	Допуск класс M		Допуск класс U	
	Ф о р м ы			
	S, T, C, R, W	D	V	S, T, C
3,97	0,08	—	—	—
4,76	0,08	—	—	0,13
5,56	0,08	0,11	—	0,13
6,35	0,08	0,11	—	0,13
7,94	0,08	0,11	—	0,13
9,52	0,08	0,11	0,18	0,13
11,11	0,13	0,15	—	—
12,70	0,13	0,15	0,25	0,20
14,29	0,13	0,15	—	—
15,88	0,15	0,18	—	0,27
17,46	0,15	0,18	—	0,27
19,05	0,15	0,18	—	0,27
22,22	0,15	—	—	0,38
25,40	0,18	—	—	0,38
31,75	0,20	—	—	0,38

Обозначение	Исполнение пластины
N	
R	
F	
A	
M	
G	
W	
T	
Q	
U	
B	
H	
C	
J	
X,V	Специальная конструкция

D мм	Длина режущей кромки							
	C	D	R	S	T	V	W	
3,97	S4	O4	O3	O3	O6	—	—	
4,76	O4	O5	O4	O4	O8	O8	S3	
5,56	O5	O6	O5	O5	O9	O9	O3	
6,00	—	—	O6	—	—	—	—	
6,35	O6	O7	O6	O6	O11	O11	O4	
7,94	O8	O9	O7	O7	O13	O13	O5	
8,00	—	—	O8	—	—	—	—	
9,52	O9	O11	O9	O9	O16	O16	O6	
10,00	—	—	O10	—	—	—	—	
11,11	O11	O13	O11	O11	O19	O19	O7	
12,00	—	—	O12	—	—	—	—	
12,70	O12	O15	O12	O12	O22	O22	O8	
14,29	O14	O17	O14	O14	O24	O24	O9	
15,88	O16	O19	O15	O15	O27	O27	O10	
16,00	—	—	O16	—	—	—	—	
17,46	O17	O21	O17	O17	O30	O30	O11	
19,05	O19	O23	O19	O19	O33	O33	O13	
20,00	—	—	O20	—	—	—	—	
22,22	O22	O27	O22	O22	O38	O38	O15	
25,00	—	—	O25	—	—	—	—	
25,40	O25	O31	O25	O25	O44	O44	O17	
31,75	O32	O38	O31	O31	O54	O54	O21	
32,00	—	—	O32	—	—	—	—	

D мм	Толщина
—	0,79
T0	1,00
O1	11,59
T1	1,98
O2	2,38
O3	3,18
T3	3,97
O4	4,76
O5	5,56
O6	6,35
O7	7,94
O9	9,52
O11	11,11
O12	12,70

D — диаметр, вписанный в пластину
 S — толщина
 R — радиус скругления

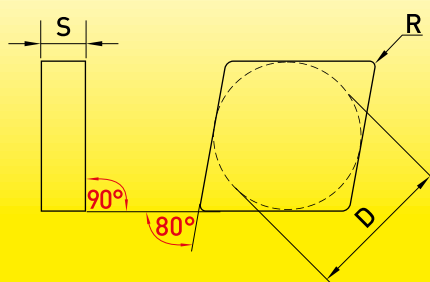

7. Радиус скругления

04

Д мм	Радиус скругления
X0	0,4
01	0,1
02	0,2
04	0,4
08	0,8
12	1,2
16	1,6
20	2,0
24	2,4
28	2,8
32	3,2
00	Круглая режущая пластина
М0	

8. Подготовка режущей кромки

S

Обозначение	Форма режущей кромки
F	 ОСТРАЯ
E	 СКРУГЛЕННАЯ
T	 С ФАСКОЙ
S	 С ФАСКОЙ И СКРУГЛЕНИЕМ

9. Ширина защитной фаски

010

ISO	Размер
010	0,1
020	0,2

10. Угол защитной фаски

20

Обозначение	Размер
10	10°
15	15°
20	20°
25	25°
30	30°

ДАННЫЕ ЗНАЧЕНИЯ ДЕЙСТВИТЕЛЬНЫ ТОЛЬКО ДЛЯ ФОРМ **T** (с фаской) и **S** (с фаской и скруглением)

11. Конструкция пластины

S

Обозначение	Тип	Dbl
M	Монолитные пластины	
S	Монолитные вставки	
A	Напайные пластинки	

12. Количество режущих кромок

4

Сорт	CBN V%	Размер основной фракции Мкр	Связка	Твердость Hv	Тип обработки	Описание	Применение	Твердость HRC	Исполнение пластин			
									Моно-литные пластины	Моно-литные вставки	Напайные пластинки	
CBNB 050	85–90	6–12	Al-TiN	3400–3700	получистовая, непрерывное резание	Высокое содержание CBN на металлической связке с Ti-основой. Этот состав обеспечивает превосходную износостойкость и термостабильность, имеет высокую твердость.	Используется в различных областях: от непрерывного до слегка прерывистого резания. Идеально подходит для обработки чугуна и металлических порошковых сплавов, быстрорежущих сталей и закаленных сталей.	45–68	●	●	●	P M K N S H
CBNB 236	85–85	20–25	Al-TiN	3300–3500	черновая, прерывистое резание	Пониженное содержание CBN с комбинированным размером зерна. Al-Ni-связка. Высокая ударная вязкость.	Обработка серого и ковкого чугуна, высокопрочных чугунов, чугунов с высоким содержанием Ni и Cr, высокомарганцевых сталей.	45–68	●			P M K N S H
CBNB 082	90–95	до 4	Al-Co	3500–3700	финишная, непрерывное/легкое прерывистое резание	Сорт с наиболее высоким содержанием CBN и субмикронной структурой металлической связки, с высокой абразивной стойкостью и теплопроводностью.	Непрерывная и легкая прерывистая обработка серых чугунов, порошковых металлических материалов и цементированной стали.	45–65	●	●	●	P M K N S H
CBNB 109	50–65	2–4	TiN	2500–2800	финишная/получистовая, непрерывное/легкое прерывистое резание	Тщательно контролируемый размер зерен и наиболее низкое содержание CBN в сочетании с матрицей TiN. Высокая стойкость к истиранию, высокая ударная вязкость и химическая стабильность.	Непрерывная и, средней прерывистости обработка закаленной стали. Обеспечивает высокое качество поверхности.	55–68	●	●	●	P M K N S H
CBNB 067	85–90	10	Al-Ti		черновая/чистовая, непрерывное резание	Сорт с высоким содержанием CBN – размером 10–12 микрон, Al-Ti керамической связкой. Обладает уникальной стойкостью к абразивному износу и ударной вязкостью.	Специально спроектирован для обработки высоко-хромистой и высококоникелевой стали, стальных валов, закаленных быстрорежущих сталей на высоких скоростях резания и с повышенной стойкостью.	45–68	●			P M K N S H
CBNB 086	85–90	17–20	Al-TiN	3300–3500	черновая/получистовая	Сорт с пониженным содержанием CBN с комбинированным размером зерна. Al-Ni-связка. Высокая ударная вязкость.	Обработка серого и ковкого чугуна, высокопрочных чугунов, чугунов с высоким содержанием Ni и Cr, высокомарганцевых сталей.	45–68	●	●		P M K N S H

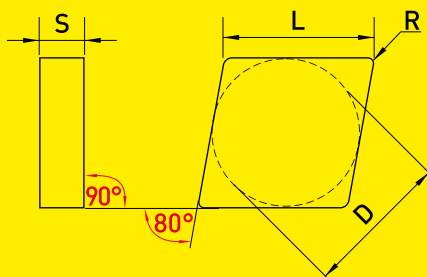
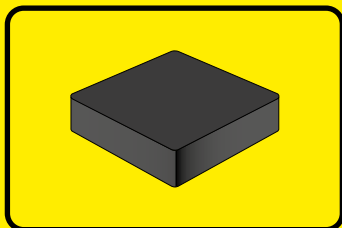

форма CNGN

ISO	D мм	L мм	S мм	R мм	СОПТА CBN					
					CBNB 050	CBNB 236	CBNB 082	CBNB 109	CBNB 067	CBNB 086
CNGN090402	9.53	9.57	4.76	0.2	○	○	○	○	○	○
CNGN090404	9.53	9.57	4.76	0.4	○	○	○	○	○	○
CNGN090408	9.53	9.57	4.76	0.8	○	○	○	○	○	○
CNGN120402	12.70	12.90	4.76	0.2	○	○	○	○	○	○
CNGN120404	12.70	12.90	4.76	0.4	○	○	○	○	○	○
CNGN120408	12.70	12.90	4.76	0.8	○	○	○	○	○	○
CNGN120608	12.70	12.90	6.35	0.8	○	○	○	○	○	○
CNGN120612	12.70	12.90	6.35	1.2	○	○	○	○	○	○
CNGN120704	12.70	12.90	7.94	0.4	○	○	○	○	○	○
CNGN120708	12.70	12.90	7.94	0.8	○	○	○	○	○	○
CNGN120712	12.70	12.90	7.94	1.2	○	○	○	○	○	○
CNGN120716	12.70	12.90	7.94	1.6	○	○	○	○	○	○
CNGN160612	15.88	16.10	6.35	1.2	○	○	○	○	○	○
CNGN160616	15.88	16.10	6.35	1.6	○	○	○	○	○	○
CNGN160708	15.88	16.10	7.94	0.8	○	○	○	○	○	○
CNGN160712	15.88	16.10	7.94	1.2	○	○	○	○	○	○
CNGN160716	15.88	16.10	7.94	1.6	○	○	○	○	○	○
CNGN160720	15.88	16.10	7.94	2.0	○	○	○	○	○	○
CNGN190612	19.05	19.40	6.35	1.2	○	○	○	○	○	○
CNGN190616	19.05	19.40	6.35	1.6	○	○	○	○	○	○
CNGN190632	19.05	19.40	6.35	3.2	○	○	○	○	○	○
CNGN190716	19.05	19.40	7.94	1.6	○	○	○	○	○	○
CNGN190720	19.05	19.40	7.94	2.0	○	○	○	○	○	○
CNGN190724	19.05	19.40	7.94	2.4	○	○	○	○	○	○
CNGN250724	25.40	25.78	7.94	2.4	○	○	○	○	○	○
CNGN250924	25.40	25.78	9.53	2.4	○	○	○	○	○	○

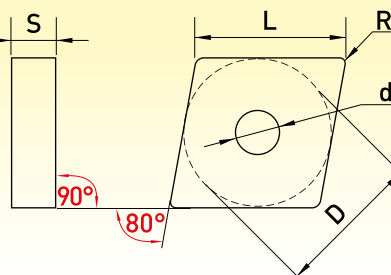
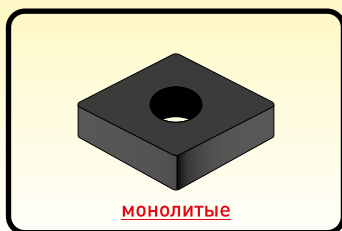
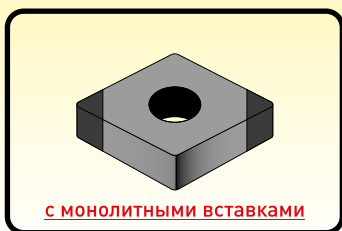

форма CNGA

ISO	D мм	L мм	S мм	R мм	d мм	СОПТА CBN					
						CBNB 050	CBNB 236	CBNB 082	CBNB 109	CBNB 067	CBNB 086
CNGA120402	12.7	12.9	4.76	0.2	5.16	○		○	○		○
CNGA120404	12.7	12.9	4.76	0.4	5.16	○		○	○		○
CNGA120408	12.7	12.9	4.76	0.8	5.16	○		○	○		○
CNGA120412	12.7	12.9	4.76	1.2	5.16	○		○	○		○

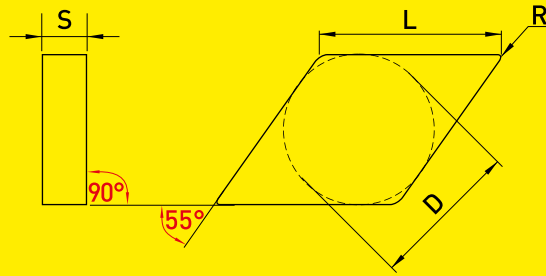
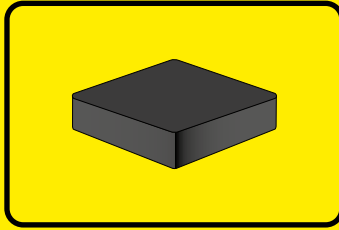

форма DNGN

ISO	D мм	L мм	S мм	R мм	СОПЛА CBN					
					CBNB 050	CBNB 236	CBNB 082	CBNB 109	CBNB 067	CBNB 086
DNGN110402	9.53	11.0	4.76	0.2	○	○	○	○	○	○
DNGN110404	9.53	11.0	4.76	0.4	○	○	○	○	○	○
DNGN110408	9.53	11.0	4.76	0.8	○	○	○	○	○	○
DNGN150412	12.70	15.5	4.76	1.2	○	○	○	○	○	○
DNGN150602	12.70	15.5	6.35	0.2	○	○	○	○	○	○
DNGN150604	12.70	15.5	6.35	0.4	○	○	○	○	○	○
DNGN150608	12.70	15.5	6.35	0.8	○	○	○	○	○	○
DNGN150612	12.70	15.5	6.35	1.2	○	○	○	○	○	○
DNGN150702	12.70	15.5	7.94	0.2	○	○	○	○	○	○
DNGN150704	12.70	15.5	7.94	0.4	○	○	○	○	○	○
DNGN150708	12.70	15.5	7.94	0.8	○	○	○	○	○	○
DNGN150712	12.70	15.5	7.94	1.2	○	○	○	○	○	○
DNGN150716	12.70	15.5	7.94	1.6	○	○	○	○	○	○

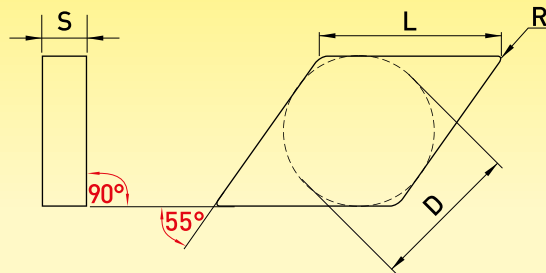
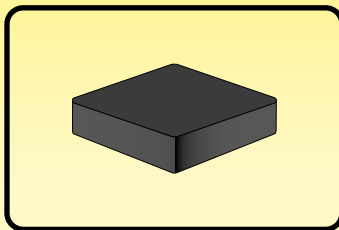

форма DNUN

ISO	D мм	L мм	S мм	R мм	СОПЛА CBN					
					CBNB 050	CBNB 236	CBNB 082	CBNB 109	CBNB 067	CBNB 086
DNUN110402	9.525	11.0	4.76	0.2	○	○	○	○	○	○
DNUN110404	9.525	11.0	4.76	0.4	○	○	○	○	○	○
DNUN110408	9.525	11.0	4.76	0.8	○	○	○	○	○	○
DNUN110412	9.525	11.0	4.76	1.2	○	○	○	○	○	○
DNUN110602	9.525	11.0	6.35	0.2	○	○	○	○	○	○
DNUN110604	9.525	11.0	6.35	0.4	○	○	○	○	○	○
DNUN110608	9.525	11.0	6.35	0.8	○	○	○	○	○	○
DNUN110612	9.525	11.0	6.35	1.2	○	○	○	○	○	○
DNUN150602	12.700	15.5	6.35	0.2	○	○	○	○	○	○
DNUN150604	12.700	15.5	6.35	0.4	○	○	○	○	○	○
DNUN150608	12.700	15.5	6.35	0.8	○	○	○	○	○	○
DNUN150612	12.700	15.5	6.35	1.2	○	○	○	○	○	○

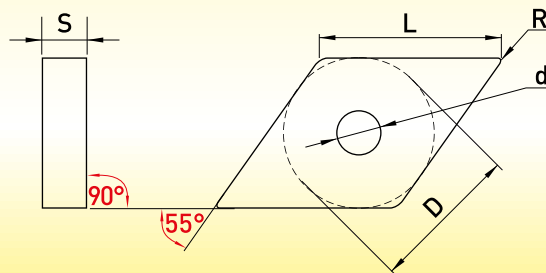
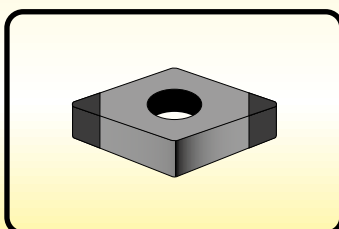

форма DNGA

ISO	D мм	L мм	S мм	R мм	d мм	СОПЛА CBN					
						CBNB 050	CBNB 236	CBNB 082	CBNB 109	CBNB 067	CBNB 086
DNGA110402	9.525	11.6	4.76	0.2	3.81	○		○	○		○
DNGA110404	9.525	11.6	4.76	0.4	3.81	○		○	○		○
DNGA110408	9.525	11.6	4.76	0.8	3.81	○		○	○		○
DNGA150408	12.700	15.5	4.76	0.8	5.16	○		○	○		○
DNGA150412	12.700	15.5	4.76	1.2	5.16	○		○	○		○
DNGA150612	12.700	15.5	4.76	1.2	5.6	○		○	○		○

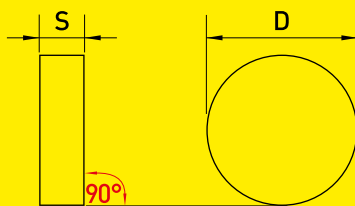
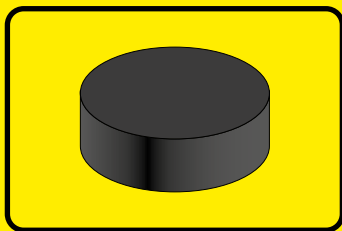

форма RNGN

ISO	D мм	S мм	СОПЛА CBN					
			CBNB 050	CBNB 236	CBNB 082	CBNB 109	CBNB 067	CBNB 086
RNGN090400	9.53	4.76	○	○	○	○	○	○
RNGN120400	12.70	4.76	○	○	○	○	○	○
RNGN120600	12.70	6.35	○	○	○	○	○	○
RNGN120700	12.70	7.94	○	○	○	○	○	○
RNGN150700	15.88	7.94	○	○	○	○	○	○
RNGN190700	19.05	7.94	○	○	○	○	○	○
RNGN2010M0	20.00	10.00	○	○	○	○	○	○
RNGN250700	25.40	7.94	○	○	○	○	○	○

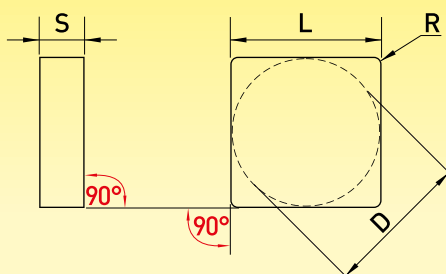
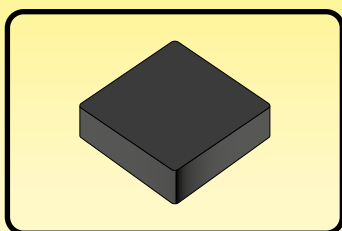

форма SNGN

ISO	D мм	L мм	S мм	R мм	СОПЛА CBN					
					CBNB 050	CBNB 236	CBNB 082	CBNB 109	CBNB 067	CBNB 086
SNGN090302	9.525	9.525	3.18	0.2	○	○	○	○	○	○
SNGN090304	9.525	9.525	3.18	0.4	○	○	○	○	○	○
SNGN090308	9.525	9.525	3.18	0.8	○	○	○	○	○	○
SNGN090312	9.525	9.525	3.18	1.2	○	○	○	○	○	○
SNGN090408	9.525	9.525	4.76	0.8	○	○	○	○	○	○
SNGN090420	9.525	9.525	4.76	2.0	○	○	○	○	○	○
SNGN120308	12.700	12.700	3.18	0.8	○	○	○	○	○	○
SNGN120402	12.700	12.700	4.76	0.2	○	○	○	○	○	○
SNGN120404	12.700	12.700	4.76	0.4	○	○	○	○	○	○
SNGN120408	12.700	12.700	4.76	0.8	○	○	○	○	○	○
SNGN120412	12.700	12.700	4.76	1.2	○	○	○	○	○	○
SNGN120416	12.700	12.700	4.76	1.6	○	○	○	○	○	○
SNGN120420	12.700	12.700	4.76	2.0	○	○	○	○	○	○
SNGN120708	12.700	12.700	7.94	0.8	○	○	○	○	○	○
SNGN120712	12.700	12.700	7.94	1.2	○	○	○	○	○	○
SNGN120716	12.700	12.700	7.94	1.6	○	○	○	○	○	○
SNGN120720	12.700	12.700	7.94	2.0	○	○	○	○	○	○
SNGN150708	15.875	15.875	7.94	0.8	○	○	○	○	○	○
SNGN150712	15.875	15.875	7.94	1.2	○	○	○	○	○	○
SNGN150716	15.875	15.875	7.94	1.6	○	○	○	○	○	○
SNGN190708	19.050	19.050	7.94	0.8	○	○	○	○	○	○
SNGN190712	19.050	19.050	7.94	1.2	○	○	○	○	○	○
SNGN190716	19.050	19.050	7.94	1.6	○	○	○	○	○	○
SNGN190720	19.050	19.050	7.94	2.0	○	○	○	○	○	○
SNGN250720	25.400	25.400	7.94	2.0	○	○	○	○	○	○
SNGN251012	25.400	25.400	10.00	1.2	○	○	○	○	○	○

форма SNMX

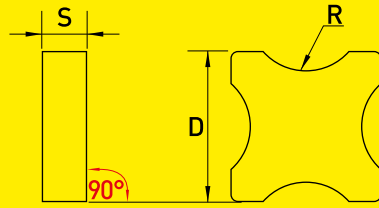
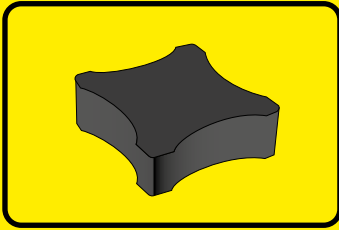

ISO	D мм	S мм	R мм	COPTA CBN					
				CBNB 050	CBNB 236	CBNB 082	CBNB 109	CBNB 067	CBNB 086
SNMX1207R09	12.70	7.94	9.00	○	○	○	○	○	○
SNMX1207R12	12.70	7.94	12.0	○	○	○	○	○	○
SNMX1207R15	12.70	7.94	15.0	○	○	○	○	○	○
SNMX1207R18	12.70	7.94	18.0	○	○	○	○	○	○
SNMX1207R20	12.70	7.94	20.0	○	○	○	○	○	○
SNMX1207R25	12.70	7.94	25.0	○	○	○	○	○	○
SNMX1207R30	12.70	7.94	30.0	○	○	○	○	○	○
SNMX1207R40	12.70	7.94	40.0	○	○	○	○	○	○
SNMX1207R50	12.70	7.94	50.0	○	○	○	○	○	○
SNMX1507R03	15.88	7.94	3.00	○	○	○	○	○	○
SNMX1507R04	15.88	7.94	4.00	○	○	○	○	○	○
SNMX1507R05	15.88	7.94	5.00	○	○	○	○	○	○
SNMX1507R06	15.88	7.94	6.00	○	○	○	○	○	○
SNMX1507R07	15.88	7.94	7.00	○	○	○	○	○	○
SNMX1910R07	19.05	10.00	7.00	○	○	○	○	○	○
SNMX1910R08	19.05	10.00	8.00	○	○	○	○	○	○
SNMX1910R09	19.05	10.00	9.00	○	○	○	○	○	○
SNMX1910R10	19.05	10.00	10.00	○	○	○	○	○	○
SNMX1910R12	19.05	10.00	12.00	○	○	○	○	○	○
SNMX1910R14	19.05	10.00	14.00	○	○	○	○	○	○
SNMX1910R16	19.05	10.00	16.00	○	○	○	○	○	○
SNMX1910R18	19.05	10.00	18.00	○	○	○	○	○	○

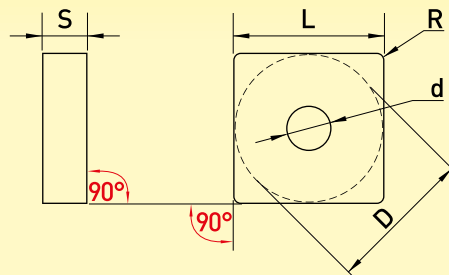
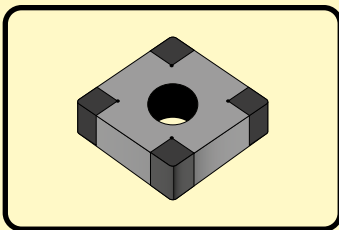

форма SNGA

ISO	D мм	L мм	S мм	R мм	d мм	COPTA CBN					
						CBNB 050	CBNB 236	CBNB 082	CBNB 109	CBNB 067	CBNB 086
SNGA120402	12.7	12.7	4.76	0.2	5.16	○		○	○		○
SNGA120404	12.7	12.7	4.76	0.4	5.16	○		○	○		○
SNGA120408	12.7	12.7	4.76	0.8	5.16	○		○	○		○
SNGA120412	12.7	12.7	4.76	1.2	5.16	○		○	○		○

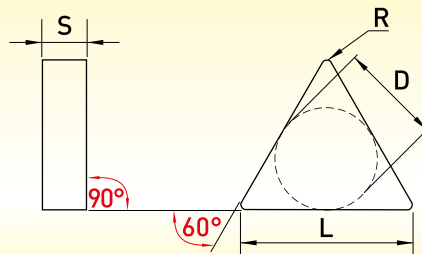
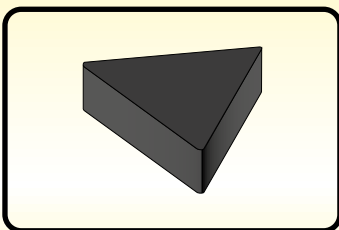

форма TNGN

ISO	D мм	L мм	S мм	R мм	COPTA CBN					
					CBNB 050	CBNB 236	CBNB 082	CBNB 109	CBNB 067	CBNB 086
TNGN110302	6.350	11.0	3.18	0.2	○	○	○	○	○	○
TNGN110304	6.350	11.0	3.18	0.4	○	○	○	○	○	○
TNGN110308	6.350	11.0	3.18	0.8	○	○	○	○	○	○
TNCN160402	9.525	16.5	4.76	0.2	○	○	○	○	○	○
TNCN160404	9.525	16.5	4.76	0.4	○	○	○	○	○	○
TNGN160408	9.525	16.5	4.76	0.8	○	○	○	○	○	○
TNGN160608	9.525	16.5	4.76	0.8	○	○	○	○	○	○
TNGN160612	9.525	16.5	6.35	1.2	○	○	○	○	○	○
TNGN220712	12.700	22.0	7.94	1.2	○	○	○	○	○	○
TNGN220716	12.700	22.0	7.94	1.6	○	○	○	○	○	○

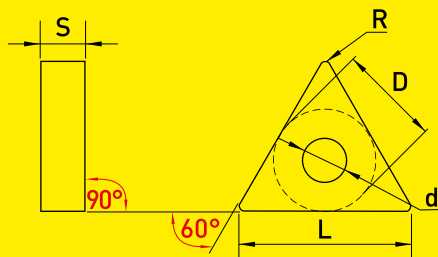
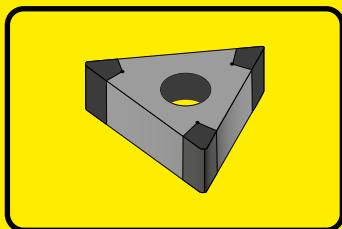

форма TNGA

ISO	D мм	L мм	S мм	R мм	d мм	СОПТА CBN					
						CBNB 050	CBNB 236	CBNB 082	CBNB 109	CBNB 067	CBNB 086
TNGA160402	9.525	16.5	4.76	0.2	3.81	○		○	○		○
TNGA160404	9.525	16.5	4.76	0.4	3.81	○		○	○		○
TNGA160408	9.525	16.5	4.76	0.8	3.81	○		○	○		○
TNGA160412	9.525	16.5	4.76	1.2	3.81	○		○	○		○
TNGA220402	12.700	22.0	4.76	0.2	5.16	○		○	○		○
TNGA220404	12.700	22.0	4.76	0.4	5.16	○		○	○		○
TNGA220408	12.700	22.0	4.76	0.8	5.16	○		○	○		○
TNGA220412	12.700	22.0	4.76	1.2	5.16	○		○	○		○

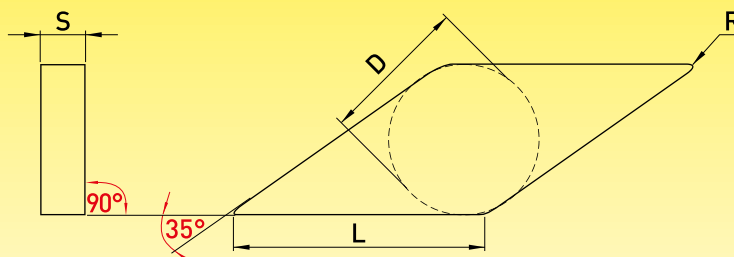
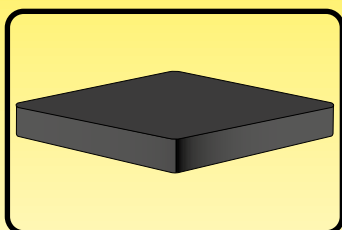

форма VNGN

ISO	D мм	L мм	S мм	R мм	СОПТА CBN						
					CBNB 050	CBNB 236	CBNB 082	CBNB 109	CBNB 067	CBNB 086	
VNGN160402	9.53	16.61	4.76	0.2		○	○	○	○	○	○
VNGN160404	9.53	16.61	4.76	0.4		○	○	○	○	○	○
VNGN160408	9.53	16.61	4.76	0.8		○	○	○	○	○	○
VNGN160412	9.53	16.61	4.76	1.2		○	○	○	○	○	○
VNGN160602	9.53	16.61	6.35	0.2		○	○	○	○	○	○
VNGN160604	9.53	16.61	6.35	0.4		○	○	○	○	○	○
VNGN160608	9.53	16.61	6.35	0.8		○	○	○	○	○	○
VNGN160612	9.53	16.61	6.35	1.2		○	○	○	○	○	○
VNGN160702	9.53	16.61	7.94	0.2		○	○	○	○	○	○
VNGN160704	9.53	16.61	7.94	0.4		○	○	○	○	○	○
VNGN160708	9.53	16.61	7.94	0.8		○	○	○	○	○	○
VNGN160712	9.53	16.61	7.94	1.2		○	○	○	○	○	○
VNGN160716	9.53	16.61	7.94	1.6		○	○	○	○	○	○

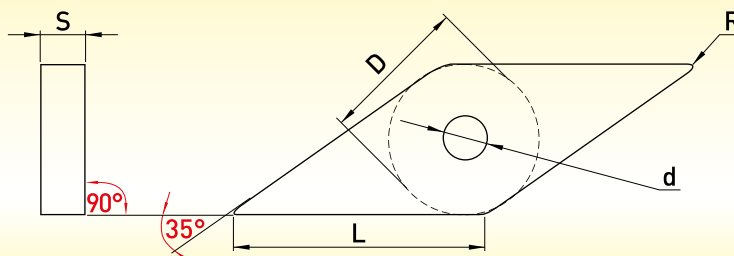
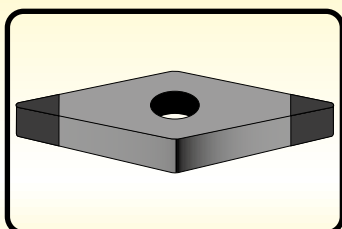

форма VNGA

ISO	D мм	L мм	S мм	R мм	d мм	СОПТА CBN					
						CBNB 050	CBNB 236	CBNB 082	CBNB 109	CBNB 067	CBNB 086
VNGA160402	9.525	16.6	4.76	0.2	3.81	○		○	○		○
VNGA160404	9.525	16.6	4.76	0.4	3.81	○		○	○		○
VNGA160408	9.525	16.6	4.76	0.8	3.81	○		○	○		○
VNGA160412	9.525	16.6	4.76	1.2	3.81	○		○	○		○

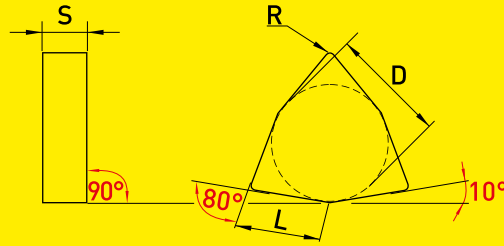
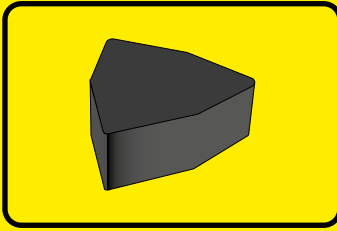

форма WNGN

ISO	D мм	L мм	S мм	R мм	СОПЛА CBN					
					CBNB 050	CBNB 236	CBNB 082	CBNB 109	CBNB 067	CBNB 086
WNGN060402	9.53	6.52	4.76	0.2	○	○	○	○	○	○
WNGN060404	9.53	6.52	4.76	0.4	○	○	○	○	○	○
WNGN060408	9.53	6.52	4.76	0.8	○	○	○	○	○	○
WNGN060412	9.53	6.52	4.76	1.2	○	○	○	○	○	○
WNGN080702	12.70	8.69	7.94	0.2	○	○	○	○	○	○
WNGN080704	12.70	8.69	7.94	0.4	○	○	○	○	○	○
WNGN080708	12.70	8.69	7.94	0.8	○	○	○	○	○	○
WNGN080712	12.70	8.69	7.94	1.2	○	○	○	○	○	○

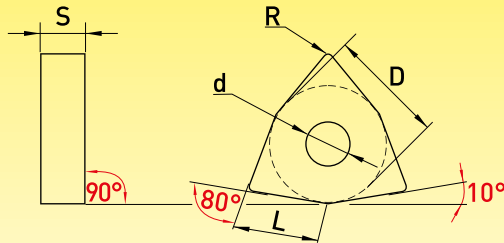
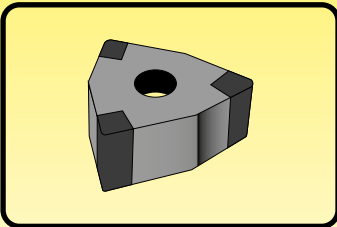

форма WNGA

ISO	D мм	L мм	S мм	R мм	d мм	СОПЛА CBN					
						CBNB 050	CBNB 236	CBNB 082	CBNB 109	CBNB 067	CBNB 086
WNGA060402	9.525	6.50	4.76	0.2	3.81	○		○	○		○
WNGA060404	9.525	6.50	4.76	0.4	3.81	○		○	○		○
WNGA060408	9.525	6.50	4.76	0.8	3.81	○		○	○		○
WNGA060412	9.525	6.50	4.76	1.2	3.81	○		○	○		○
WNGA080402	12.700	8.79	4.76	0.2	5.16	○		○	○		○
WNGA080404	12.700	8.79	4.76	0.4	5.16	○		○	○		○
WNGA080408	12.700	8.79	4.76	0.8	5.16	○		○	○		○
WNGA080412	12.700	8.79	4.76	1.2	5.16	○		○	○		○

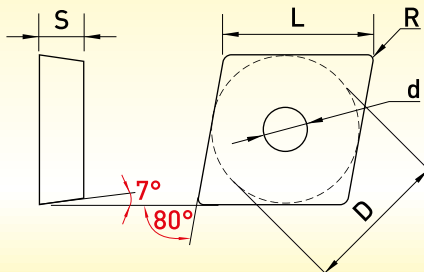
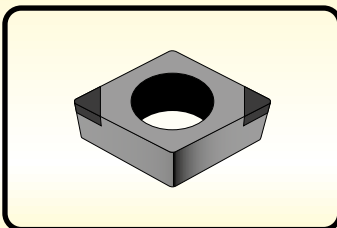

форма CCGW

ISO	D мм	L мм	S мм	R мм	d мм	СОПЛА CBN					
						CBNB 050	CBNB 236	CBNB 082	CBNB 109	CBNB 067	CBNB 086
CCGW060202	6.350	2.5	2.38	0.2	2.8	○		○	○		○
CCGW060204	6.350	2.5	2.38	0.4	2.8	○		○	○		○
CCGW060208	6.350	2.4	2.38	0.8	2.8	○		○	○		○
CCGW09T302	9.525	2.5	3.97	0.2	4.4	○		○	○		○
CCGW09T304	9.525	2.5	3.97	0.4	4.4	○		○	○		○
CCGW09T308	9.525	2.4	3.97	0.8	4.4	○		○	○		○
CCGW120408	12.700	2.4	4.76	0.8	5.5	○		○	○		○

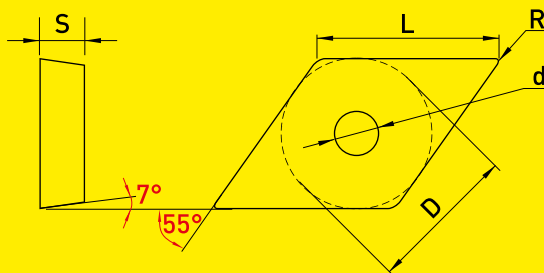
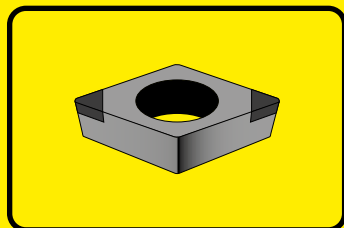

форма DCGW

ISO	D мм	L мм	S мм	R мм	d мм	СОПТА CBN					
						CBNB 050	CBNB 236	CBNB 082	CBNB 109	CBNB 067	CBNB 086
DCGW070202	6.350	2.7	2.38	0.2	2.8	○		○	○		○
DCGW070204	6.350	2.5	2.38	0.4	2.8	○		○	○		○
DCGW11T302	9.525	2.5	3.97	0.2	4.4	○		○	○		○
DCGW11T304	9.525	2.5	3.97	0.4	4.4	○		○	○		○
DCGW11T308	9.525	2.3	3.97	0.8	4.4	○		○	○		○

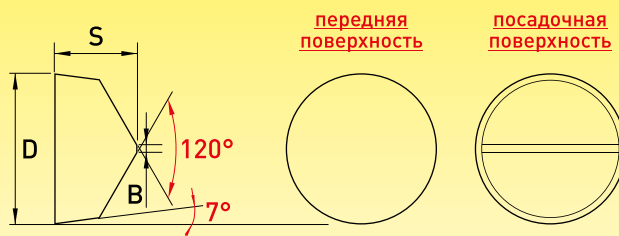
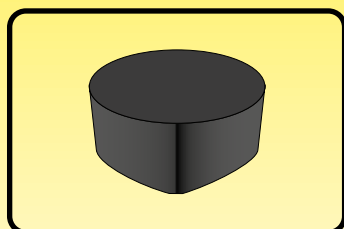

форма RCGV

ISO	D мм	S мм	B мм	СОПТА CBN					
				CBNB 050	CBNB 236	CBNB 082	CBNB 109	CBNB 067	CBNB 086
RCGV060400	6.350	4.76	0.8	○	○	○	○	○	○
RCGV060600	6.350	6.35	0.8	○	○	○	○	○	○
RCGV090700	9.525	7.94	1.0	○	○	○	○	○	○
RCGV120700	12.700	7.94	2.0	○	○	○	○	○	○
RCGV151000	15.875	10.00	2.0	○	○	○	○	○	○
RCGV191000	19.050	10.00	2.0	○	○	○	○	○	○
RCGV201200	20.000	12.00	2.0	○	○	○	○	○	○
RCGV251200	25.400	12.00	2.0	○	○	○	○	○	○

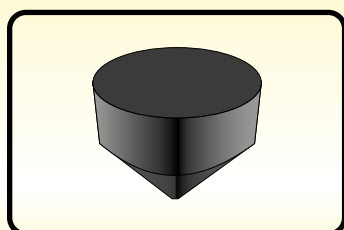

форма RCGY

ISO	D мм	S мм	B мм	СОПТА CBN					
				CBNB 050	CBNB 236	CBNB 082	CBNB 109	CBNB 067	CBNB 086
RCGY060400	6.350	4.76	0.6	○	○	○	○	○	○
RCGY060500	6.350	5.00	0.6	○	○	○	○	○	○
RCGY060700	6.350	7.94	0.6	○	○	○	○	○	○
RCGY090700	9.525	7.94	1.2	○	○	○	○	○	○
RCGY120700	12.700	7.94	1.2	○	○	○	○	○	○

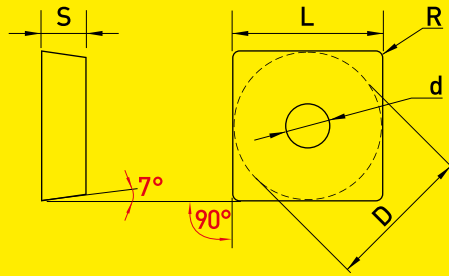
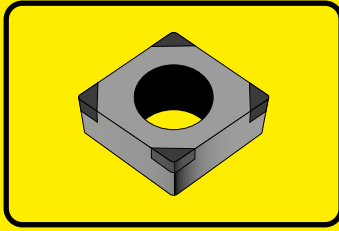

форма SCGW

ISO	D мм	L мм	S мм	R мм	d мм	КОПТА CBN					
						CBNB 050	CBNB 236	CBNB 082	CBNB 109	CBNB 067	CBNB 086
SCGW120402	12.7	2.5	4.76	0.2	4.40	○		○	○		○
SCGW120404	12.7	2.5	4.76	0.4	4.40	○		○	○		○
SCGW120408	12.7	2.3	4.76	0.8	4.40	○		○	○		○
SCGW120412	12.7	2.1	4.76	1.2	4.40	○		○	○		○
SCGW120402	12.7	2.5	4.76	0.2	5.56	○		○	○		○
SCGW120404	12.7	2.5	4.76	0.4	5.56	○		○	○		○
SCGW120408	12.7	2.3	4.76	0.8	5.56	○		○	○		○
SCGW120412	12.7	2.1	4.76	1.2	5.56	○		○	○		○
SCGW120402	12.7	2.5	4.76	0.2	5.56	○		○	○		○
SCGW120404	12.7	2.5	4.76	0.4	5.56	○		○	○		○
SCGW120408	12.7	2.3	4.76	0.8	5.56	○		○	○		○
SCGW120412	12.7	2.1	4.76	1.2	5.56	○		○	○		○

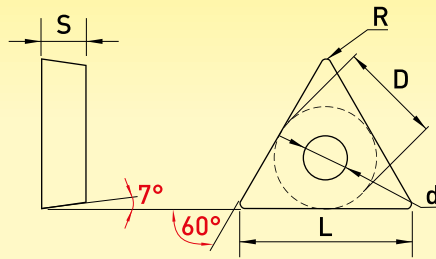
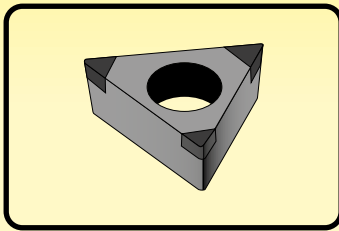

форма TCGW

ISO	D мм	L мм	S мм	R мм	d мм	КОПТА CBN					
						CBNB 050	CBNB 236	CBNB 082	CBNB 109	CBNB 067	CBNB 086
TCGW110202	6.350	2.5	2.38	0.2	2.8	○		○	○		○
TCGW110204	6.350	2.5	2.38	0.4	2.8	○		○	○		○
TCGW110208	6.350	2.0	2.38	0.8	2.8	○		○	○		○
TCGW110304	6.350	2.5	3.18	0.4	2.8	○		○	○		○
TCGW16T302	9.525	2.5	3.97	0.2	4.4	○		○	○		○
TCGW16T304	9.525	2.5	3.97	0.4	4.4	○		○	○		○
TCGW16T308	9.525	2.0	3.97	0.8	4.4	○		○	○		○
TCGW16T308	9.525	2.2	3.97	0.8	4.4	○		○	○		○

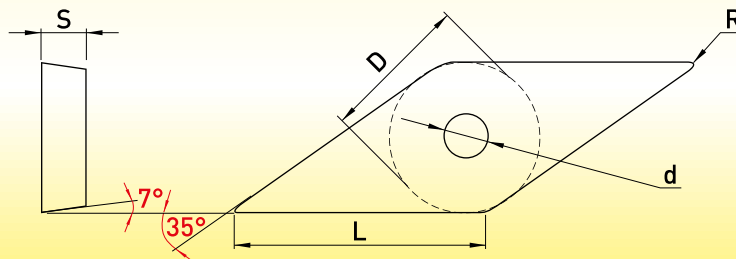
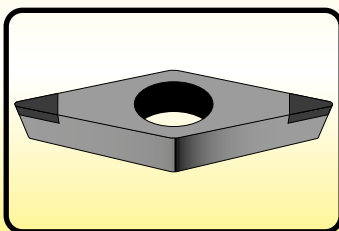

форма VCGW

ISO	D мм	L мм	S мм	R мм	d мм	КОПТА CBN					
						CBNB 050	CBNB 236	CBNB 082	CBNB 109	CBNB 067	CBNB 086
VCGW160402	9.525	2.8	4.76	0.2	4.4	○		○	○		○
VCGW160404	9.525	2.8	4.76	0.4	4.4	○		○	○		○
VCGW160408	9.525	2.5	4.76	0.8	4.4	○		○	○		○
VCGW160412	9.525	2.0	4.76	1.2	4.4	○		○	○		○



ИНСТРУМЕНТ ДЛЯ НАРЕЗАНИЯ РЕЗЬБЫ

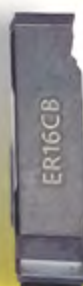
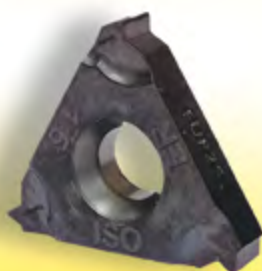
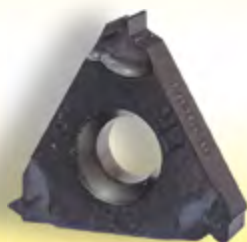

РАЗДЕЛ 3

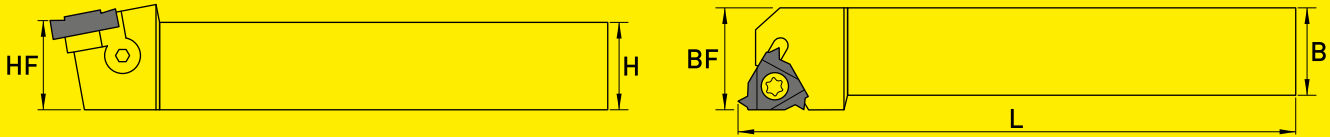

УРП	Артикул	Н мм	В мм	L мм	HF мм	BF мм	Пластины режущие	Винт режущей пластины	Ключ	Пластины опорные		Винт опорной пластины	Ключ
										Правые	Левые		
6	SG05 R/L 0808H06	8	8	100	8	11	TG05 R/L 06	M2.2x6.3	T07				
8	SG05 R/L 0808H08	8	8	100	8	11	TG05 R/L 08	M2.5x6.5	T07				
11	SG05 R/L 0808H11	8	8	100	8	11	TG05 R/L 11	M3.0x7.2	T08	—	—	—	—
	SG05 R/L 1010H11	10	10	100	10	11							
	SG05 R/L 1212H11	12	12	100	12	12							
16	SG05 R/L 1616H16	16	16	100	16	20	TG05 R/L 16	M3.5x12.0	T15	AT16E	AT16N	M3x5	S2.5
	SG05 R/L 2020K16	20	20	125	20	25							
	SG05 R/L 2525M16	25	25	150	25	32							
	SG05 R/L 3232P16	32	32	170	32	32							
	SG05 R/L 323240P16	32	32	170	32	40							
22	SG05 R/L 2525M22	25	25	150	25	32	TG05 R/L 22	M4.0x14.0	T15	AT22E	AT22N	M3x5	S2.5
	SG05 R/L 3232P22	32	32	170	32	32							
	SG05 R/L 323240P22	32	32	170	32	40							
27	SG05 R/L 2525M27	25	25	150	25	35	TG05 R/L 27	M6.0x16.0	T20	AT27E	AT27N	M3x5	S2.5
	SG05 R/L 3232P27	32	32	170	32	40							
	SG05 R/L 4040R27	40	40	200	40	40							
	SG05 R/L 5050S27	50	50	250	50	40							

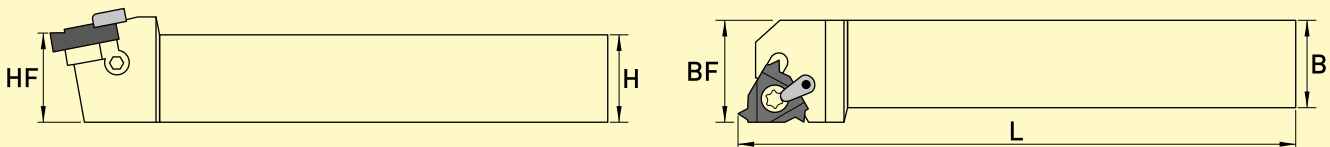

УРП	Артикул	Н мм	В мм	L мм	HF мм	BF мм	Пластины режущие	Прижим тип С	Ключ	Винт	Пластины опорные		Винт опорной пластины	Ключ
											Правые	Левые		
16	SCG05 R/L 2020K16	20	20	125	20	25	TG05 R/L 16	C-16	T15	SC-16	AT16E	AT16N	M3x5	S2.5
	SCG05 R/L 2525M16	25	25	150	25	30								
	SCG05 R/L 3232P16	32	32	170	32	37								
22	SCG05 R/L 2525M22	25	25	150	25	30	TG05 R/L 22	C-22	T15	SC-22	AT22E	AT22N	M3x5	S2.5
	SCG05 R/L 3232P22	32	32	170	32	37								
	SCG05 R/L 4040R22	40	40	200	40	45								

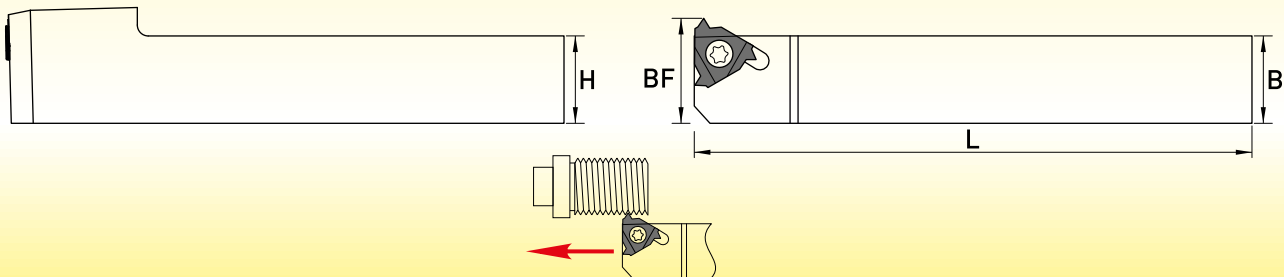

УРП	Артикул	Н мм	В мм	L мм	BF мм	Пластины режущие	Винт	Ключ	Пластины опорные		Винт опорной пластины	Ключ
									Правые	Левые		
16	SCG05 R 1012H16	10	12	100	15	TG05 R 16	M3.5x8.0	T15	—	—	—	—
	SCG05 R 1212H16	12	12	100	15				—	—	—	—
	SCG05 R 1616K16	16	16	125	20				AT16E	—	M3x5	S2.5
	SCG05 R 1616K16	20	20	125	24				AT16E	—	M3x5	S2.5



УРП	Артикул	Н мм	В мм	Л мм	HF мм	BF мм	Пластины режущие	Винт режущей пластины	Ключ	Пластины опорные	Винт опорной пластины	Ключ
22	SU05 R/L 3232P22	32	32	170	32	37	TU05 R/L 22	M4x14	T15	ATU 22	M3x5	S2.5
	SU05 R/L 4040R22	40	40	200	40	45						
27	SU05 R/L 3232P27	32	32	170	32	37	TU05 R/L 27	M6x16	T20	ATU 27	M3x5	S2.5
	SU05 R/L 4040R27	40	40	200	40	45						
	SU05 R/L 5050S27	50	50	250	50	55						

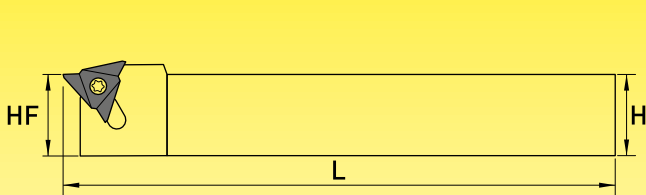

УРП	Артикул	Н мм	В мм	Л мм	HF мм	BF мм	С мм	С1 мм	С2 мм	С3 мм	Р мм	Пластины режущие	Винт режущей пластины	Ключ
16	ST305 R/L 1010H16	10	10	100	14	10	14.5	11.5	6.4	7	3	TT305 R/L 16	M3.2x12	T15
	ST305 R/L 1212H16	12	12	100	14	12	14.5	11.5	8.4	7	3			
	ST305 R/L 1616H16	16	16	100	16	16	14.5	11.5	12.4	7	3			
	ST305 R/L 2020K16	20	20	125	20	20	16.5	11.5	16.4	7	3			
	ST305 R/L 2525M16	25	25	150	25	25	16.5	11.5	21.4	7	3			
	ST305 R/L 3232P16	32	32	170	32	32	16.5	11.5	28.4	7	3			
	ST305 R/L 4040R16	40	40	200	40	40	16.5	11.5	36.4	7	3			

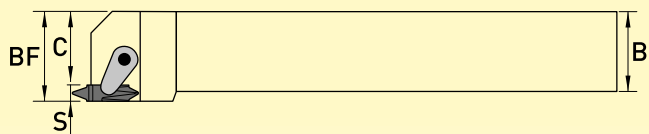
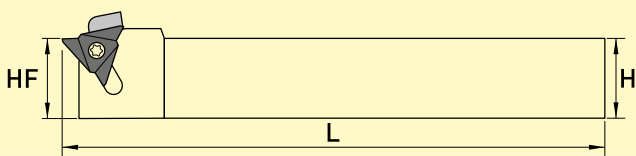

УРП	Артикул	Н мм	В мм	Л мм	HF мм	BF мм	С мм	С мм	Пластины режущие	Винт режущей пластины	Ключ	Прижим тип С	Винт	Ключ
27	SCT305 R/L 3232P2706	32	32	170	32	32	26	6	TT305 R/L 27	M6x16	T20	CL-27	XNS-510	5/32
	SCT305 R/L 3232P2708					34		8						
	SCT305 R/L 3232P2710					36		10						
	SCT305 R/L 4040R2706	40	40	200	40	40	34	6						
	SCT305 R/L 4040R2708					42		8						
	SCT305 R/L 4040R2710					44		10						

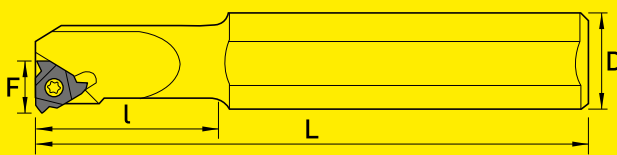

Без каналов СОЖ

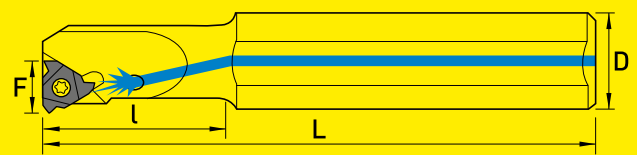

С каналами СОЖ

УРП	Артикул	D мм	F мм	L мм	L мм	D min	СОЖ	Пластины режущие	Винт режущей пластины	Ключ	Пластины опорные		Винт опорной пластины	Ключ
											Правые	Левые		
6	SG09 R/L 0706H06S	6	3.3	10	100	7		TG09 R/L 06	M2.2x6.5	T07				
8	SG09 R/L 0908H08S	8	4.6	15	100	9		TG09 R/L 08	M2.5x6.5	T-07				
11	SG09 R/L 1210H11S	10	7.2	25	100	12		TG09 R/L 11	M3.0x7.2	T08	—	—	—	—
	SG09 R/L 1310K11S	10	6.5	22	125	13								
	SG09 R/L 1310K11A	10	6.5	22	125	13	●							
	SG09 R/L 1612K11S	12	9.0	32	125	16								
	SG09 R/L 1612M11S	12	8.0	26	150	16								
	SG09 R/L 1612M11A	12	8.0	26	150	16	●							
16	SG09 R/L 2016M16S	16	12.0	32	150	20		TG09 R/L 16	M3.5x12.0	T15	AT16E	AT16N	M3x5	S2.5
	SG09 R/L 1916Q16S	16	10.0	36	180	19								
	SG09 R/L 1916Q16A	16	10.0	36	180	19	●							
	SG09 R/L 2520Q16S	20	14.0	40	180	25								
	SG09 R/L 2420R16S	20	12.0	40	200	24								
	SG09 R/L 2420R16A	20	12.0	40	200	24	●							
	SG09 R/L 2925R16S	25	14.5	45	200	29								
	SG09 R/L 2925R16A	25	14.5	45	200	29	●							
	SG09 R/L 3025R16S	25	17.5	50	200	30								
	SG09 R/L 3632S16S	32	18.5	45	250	36								
	SG09 R/L 3632S16A	32	18.5	45	250	36	●							
SG09 R/L 3832S16S	32	22.0	55	250	38									
22	SG09 R/L 3832S22S	32	22.0	55	250	38		TG09 R/L 22	M4.0x12.0	T15	AT22E	AT22N		
27	SG09 R/L 4032S27S	32	22.6	55	250	40		TG09 R/L 27	M6.0x16.0	T20	AT27E	AT27N		
	SG09 R/L 4840T27S	40	26.6	60	300	48								

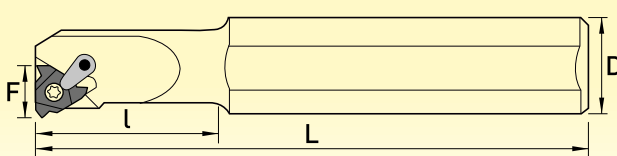

Без каналов СОЖ

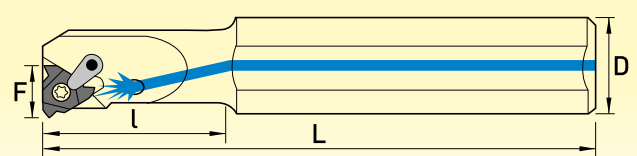

С каналами СОЖ

УРП	Артикул	D мм	F мм	L мм	L мм	D min	СОЖ	Пластины режущие	Прижим тип С	Винт режущей пластины	Ключ	Пластины опорные		Винт опорной пластины	Ключ
												Правые	Левые		
16	SCG09 R/L 2420R16S	20	12.0	40	200	24		TG09 R/L 16	C-16	M3.5x12.0	T15	AT16E	AT16N	M3x5	S2.5
	SCG09 R/L 2420R16A	20	12.0	40	200	24	●								
	SCG09 R/L 2925R16S	25	14.5	45	200	29									
	SCG09 R/L 2925R16A	25	14.5	45	200	29	●								
	SCG09 R/L 3632S16S	32	18.5	45	250	36									
	SCG09 R/L 3632S16A	32	18.5	45	250	36	●								

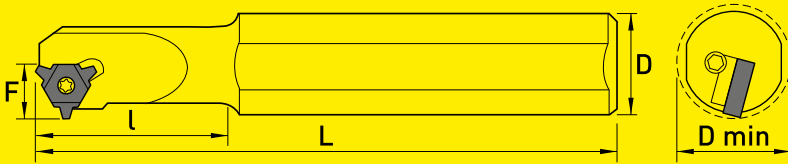

УРП	Артикул	D мм	F мм	L мм	L мм	D min	Пластины режущие	Винт режущей пластины	Ключ	Пластины опорные	Винт опорной пластины	Ключ
22	SU09 R/L 4232S22	32	25.5	60	250	42	TU09 R22	M4x14	T15	ATU 22	M3x5	S2.5
	SU09 R/L 5140T22	40	29.5	60	300	51	TUN R22					
27	SU09 R/L 4232S27	32	24.7	60	250	42	TU09 R27 TUN R27	M6x16	T20	ATU 27	M3x5	S2.5
	SU09 R/L 5340T27	40	29.4	60	300	53						
	SU09 R/L 6350U27	50	34.3	75	350	63						
	SU09 R/L 7460V27	60	39.3	75	400	74						

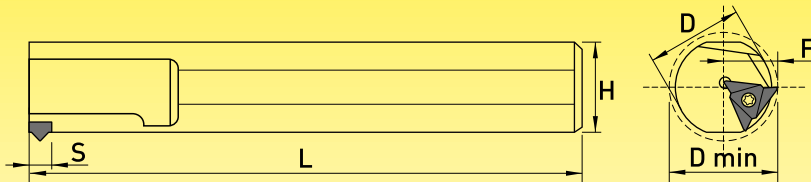

УРП	Артикул	D мм	F мм	L мм	H мм	S мм	D min	Пластины режущие	Винт режущей пластины	Ключ
27	ST309 R/L 4940T2706	40	28.4	300	38	6	49	TT305 R/L 27	M6x16	T20
	ST309 R/L 4940T2708	40	28.4	300	38	8	49		M6x20	
	ST309 R/L 4940T2710	40	28.4	300	38	10	49		M6x20	
	ST309 R/L 5950U2706	50	33.4	350	48	6	59		M6x16	
	ST309 R/L 5950U2708	50	33.4	350	48	8	59		M6x20	
	ST309 R/L 5950U2710	50	33.4	350	48	10	59		M6x20	
	ST309 R/L 6960V2706	60	38.4	400	58	6	69		M6x16	
	ST309 R/L 6960V2708	60	38.4	400	58	8	69		M6x20	
	ST309 R/L 6960V2710	60	38.4	400	58	10	69		M6x20	



С ПОКРЫТИЕМ	МАРКА СПЛАВА	ОПИСАНИЕ		05	10	15	20	25	30	35	40	Vc м/мин	
	FG04	Универсальный твердый сплав с покрытием TiAlN. Используется для черновой и получистовой обработки сталей, нержавеющей сталей, чугунов.	P										60-140
			M										40-120
			K										60-120
N													
S													
H													
			05	10	15	20	25	30	35	40			
OPM25	Мелкозернистый твердый сплав с высоким содержанием кобальта. Превосходная прочность режущей кромки в сочетании с хорошей термостойкостью. PVD износостойкое покрытие AlTiN с очень малым коэффициентом трения и высокой температурой оксидации, хорошей нано-твердостью. Основное применение — фрезерование и сверление сталей и нержавеющей сталей.	P										60-140	
		M										40-120	
		K										60-120	
		N											
		S										20-50	
		H											
			05	10	15	20	25	30	35	40			
OU15	Сплав с PVD покрытием. Мелкозернистая, твердая основа обеспечивает максимальную износостойкость. Применяется для точения всех видов материалов.	P										80-160	
		M										60-130	
		K										80-150	
		N										300-600	
		S										30-60	
		H										20-30	

ПО ЗАПРОСУ ПОСТАВЛЯЮТСЯ ПЛАСТИНЫ ДЛЯ СЛЕДУЮЩИХ ТИПОВ РЕЗЬБ:

MJ, UNJ, BSW, PG, TR, RD, BSP, BSPT, NPT, NPTF.

ОБЗОР ПЛАСТИН ВЫШЕПЕРЕЧИСЛЕННЫХ РЕЗЬБ ОЖИДАЙТЕ В СЛЕДУЮЩЕЙ РЕДАКЦИИ КАТАЛОГА.

ПЛАСТИНЫ ДЛЯ НАРУЖНОЙ РЕЗЬБЫ

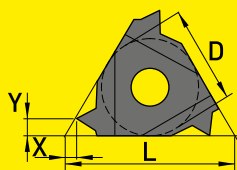
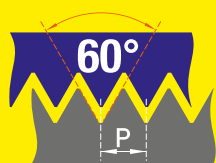

P	★	★	★	
M	★	★	★	
K	★		★	
N			★	★
S		★	★	
H				

Сплавы

УРП	Артикул	Д мм (дюйм)	Р мм	ТPI	L мм	Х мм	У мм	FG04	OPM25	OU15	RN20
11	TG05 R/L 11A60	6.35 (1/4")	0.50~1.5	48.0~16	11	0.80	0.90	⊙	⊙	⊙	⊙
16	TG05 R/L 16A60	9.52 (3/8")	0.50~1.5	48.0~16	16	0.50	0.90	⊙	⊙	⊙	⊙
16	TG05 R/L 16AG60		0.50~3.0	48.0~8	16	1.20	1.70	⊙	⊙	⊙	⊙
16	TG05 R/L 16G60		1.75~3.0	14.0~8	16	1.20	1.70	⊙	⊙	⊙	⊙
22	TG05 R/L 22N60	12.70 (1/2")	3.50~5.0	7.0~5	22	1.70	2.50	⊙	⊙	⊙	⊙
27	TG05 R/L 27Q60	15.88 (5/8")	5.50~6.0	4.5~4	27	2.10	3.10	⊙	⊙	⊙	⊙

ПЛАСТИНЫ ДЛЯ ВНУТРЕННЕЙ РЕЗЬБЫ

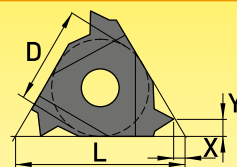
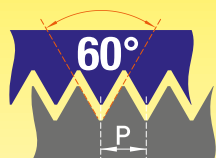

P	★	★	★	
M	★	★	★	
K	★		★	
N			★	★
S		★	★	
H				

Сплавы

УРП	Артикул	Д мм (дюйм)	Р мм	ТPI	L мм	Х мм	У мм	FG04	OPM25	OU15	RN20
6	TG09 R/L 06A60	3.97 (5/32")	0.50~1.25	48.0~20	6	0.6	0.6	⊙	⊙	⊙	⊙
8	TG09 R/L 08A60	4.76 (3/16")	0.50~1.50	48.0~16	8	0.6	0.7	⊙	⊙	⊙	⊙
11	TG09 R/L 11A60	6.35 (1/4")	0.50~1.50	48.0~16	11	0.8	0.9	⊙	⊙	⊙	⊙
16	TG09 R/L 16A60	9.52 (3/8")	0.50~1.50	48.0~16	16	0.8	0.9	⊙	⊙	⊙	⊙
16	TG09 R/L 16AG60		0.50~3.00	48.0~8	16	1.2	1.7	⊙	⊙	⊙	⊙
16	TG09 R/L 16G60		1.75~3.00	14.0~8	16	1.2	1.7	⊙	⊙	⊙	⊙
22	TG09 R/L 22N60	12.70 (1/2")	1.75~3.00	7.0~5	22	1.7	2.5	⊙	⊙	⊙	⊙
27	TG09 R/L 27Q60	15.88 (5/8")	5.50~6.00	4.5~4	27	1.8	2.7	⊙	⊙	⊙	⊙

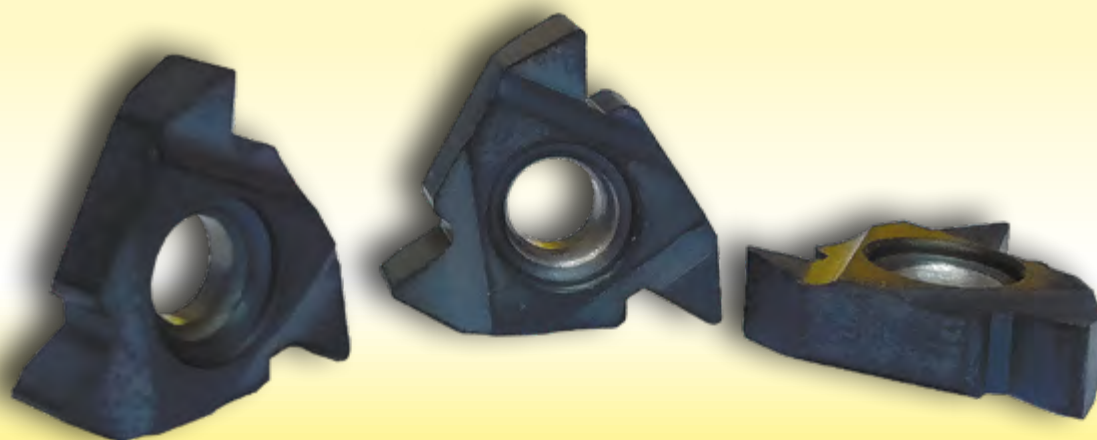

ПЛАСТИНЫ ДЛЯ НАРУЖНОЙ РЕЗЬБЫ

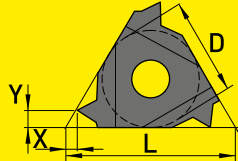
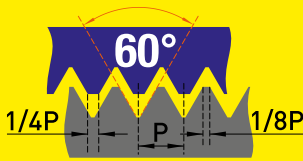

P	★	★	★	
M	★	★	★	
K	★		★	
N			★	★
S		★	★	
H				

УРП	Артикул	D мм (дюйм)	P мм	L мм	X мм	Y мм	Сплавы			
							FG04	OPM25	OU15	RN20
11.0	TG05 R/L 11 ISO050	6.35 (1/4")	0.50	11.0	0.6	0.6	⊙	⊙	⊙	⊙
11.0	TG05 R/L 11 ISO075		0.75	11.0	0.6	0.6	⊙	⊙	⊙	⊙
11.0	TG05 R/L 11 ISO100		1.00	11.0	0.7	0.7	⊙	⊙	⊙	⊙
11.0	TG05 R/L 11 ISO125		1.25	11.0	0.8	0.9	⊙	⊙	⊙	⊙
11.0	TG05 R/L 11 ISO150		1.50	11.0	0.8	1.0	⊙	⊙	⊙	⊙
11.0	TG05 R/L 11 ISO175		1.75	11.0	0.8	1.1	⊙	⊙	⊙	⊙
16.0	TG05 R/L 16 ISO050	9.52 (3/8")	0.50	16.0	0.6	0.6	●	⊙	⊙	⊙
16.0	TG05 R/L 16 ISO075		0.75	16.0	0.6	0.6	●	⊙	⊙	⊙
16.0	TG05 R/L 16 ISO100		1.00	16.0	0.7	0.7	●	⊙	⊙	⊙
16.0	TG05 R/L 16 ISO125		1.25	16.0	0.6	0.9	●	⊙	⊙	⊙
16.0	TG05 R/L 16 ISO150		1.50	16.0	0.8	1.0	●	⊙	⊙	⊙
16.0	TG05 R/L 16 ISO175		1.75	16.0	0.9	1.2	●	⊙	⊙	⊙
16.0	TG05 R/L 16 ISO200	2.00	16.0	1.0	1.3	●	⊙	⊙	⊙	
16.0	TG05 R/L 16 ISO250	2.50	16.0	1.1	1.5	●	⊙	⊙	⊙	
16.0	TG05 R/L 16 ISO300	3.00	16.0	1.2	1.6	●	⊙	⊙	⊙	
22.0	TG05 R/L 22 ISO350	12.70 (1/2")	3.50	22.0	1.6	2.3	⊙	⊙	⊙	⊙
22.0	TG05 R/L 22 ISO400		4.00	22.0	1.6	2.3	⊙	⊙	⊙	⊙
22.0	TG05 R/L 22 ISO450		4.50	22.0	1.7	2.4	⊙	⊙	⊙	⊙
22.0	TG05 R/L 22 ISO500		5.00	22.0	1.7	2.5	⊙	⊙	⊙	⊙
27.5	TG05 R/L 27 ISO550	15.88 (5/8")	5.50	27.5	1.9	2.7	⊙	⊙	⊙	⊙
27.5	TG05 R/L 27 ISO600		6.00	27.5	2.0	2.9	⊙	⊙	⊙	⊙

ПЛАСТИНЫ ДЛЯ ВНУТРЕННЕЙ РЕЗЬБЫ

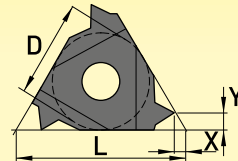
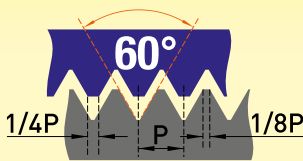

P	★	★	★	
M	★	★	★	
K	★		★	
N			★	★
S		★	★	
H				

УРП	Артикул	D мм (дюйм)	P мм	L мм	X мм	Y мм	Сплавы			
							FG04	OPM25	OU15	RN20
6	TG09 R/L 06 ISO050	3.97 5/32"	0.50	6	0.9	0.5	⊙	⊙	⊙	⊙
6	TG09 R/L 06 ISO075		0.75	6	0.8	0.5	⊙	⊙	⊙	⊙
6	TG09 R/L 06 ISO100		1.00	6	0.7	0.6	⊙	⊙	⊙	⊙
6	TG09 R/L 06 ISO125		1.25	6	0.6	0.6	⊙	⊙	⊙	⊙
8	TG09 R/L 08 ISO050	4.76 3/16"	0.50	8	0.6	0.5	⊙	⊙	⊙	⊙
8	TG09 R/L 08 ISO075		0.75	8	0.6	0.5	⊙	⊙	⊙	⊙
8	TG09 R/L 08 ISO100		1.00	8	0.6	0.6	⊙	⊙	⊙	⊙
8	TG09 R/L 08 ISO125		1.25	8	0.6	0.7	⊙	⊙	⊙	⊙
8	TG09 R/L 08 ISO150		1.50	8	0.6	0.7	⊙	⊙	⊙	⊙
8	TG09 R/L 08 ISO175	1.75	8	0.6	0.8	⊙	⊙	⊙	⊙	
11	TG09 R/L 11 ISO050	6.35 1/4"	0.50	11	0.6	0.6	⊙	⊙	⊙	⊙
11	TG09 R/L 11 ISO075		0.75	11	0.6	0.6	⊙	⊙	⊙	⊙
11	TG09 R/L 11 ISO100		1.00	11	0.6	0.7	⊙	⊙	⊙	⊙
11	TG09 R/L 11 ISO125		1.25	11	0.8	0.9	⊙	⊙	⊙	⊙
11	TG09 R/L 11 ISO150		1.50	11	0.8	1.0	⊙	⊙	⊙	⊙
11	TG09 R/L 11 ISO175		1.75	11	0.9	1.1	⊙	⊙	⊙	⊙
11	TG09 R/L 11 ISO200	2.00	11	1.0	1.3	⊙	⊙	⊙	⊙	
16	TG09 R/L 16 ISO050	9.52 3/8"	0.50	16	0.6	0.6	⊙	⊙	⊙	⊙
16	TG09 R/L 16 ISO075		0.75	16	0.6	0.6	⊙	⊙	⊙	⊙
16	TG09 R/L 16 ISO100		1.00	16	0.6	0.7	⊙	⊙	⊙	⊙
16	TG09 R/L 16 ISO125		1.25	16	0.8	0.9	⊙	⊙	⊙	⊙
16	TG09 R/L 16 ISO150		1.50	16	0.8	1.0	⊙	⊙	⊙	⊙
16	TG09 R/L 16 ISO175		1.75	16	0.9	1.2	⊙	⊙	⊙	⊙
16	TG09 R/L 16 ISO200	2.00	16	1.0	1.3	⊙	⊙	⊙	⊙	
16	TG09 R/L 16 ISO250	2.50	16	1.1	1.5	⊙	⊙	⊙	⊙	
16	TG09 R/L 16 ISO300	3.00	16	1.1	1.5	⊙	⊙	⊙	⊙	
22	TG09 R/L 22 ISO350	12.70 1/2"	3.50	22	1.6	2.3	⊙	⊙	⊙	⊙
22	TG09 R/L 22 ISO400		4.00	22	1.6	2.3	⊙	⊙	⊙	⊙
22	TG09 R/L 22 ISO450		4.50	22	1.6	2.4	⊙	⊙	⊙	⊙
22	TG09 R/L 22 ISO500		5.00	22	1.6	2.5	⊙	⊙	⊙	⊙
27	TG09 R/L 27 ISO550	15.88 5/8"	5.50	27	1.9	2.7	⊙	⊙	⊙	⊙
27	TG09 R/L 27 ISO600		6.00	27	2.0	2.9	⊙	⊙	⊙	⊙

ИНСТРУМЕНТ

ДЛЯ ОТРЕЗКИ

И НАРЕЗАНИЯ КАНАВОК

РАЗДЕЛ 4

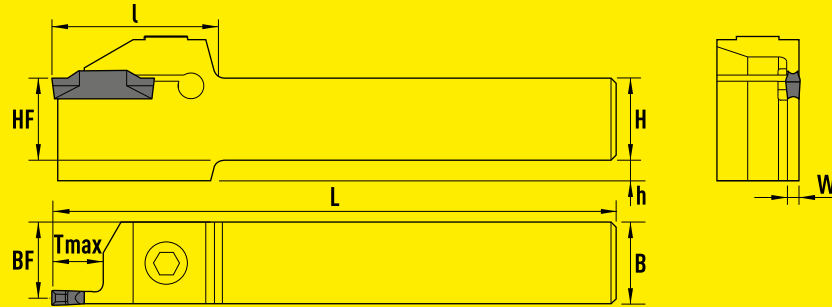
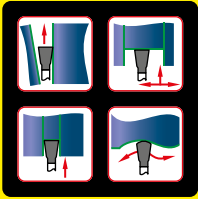

Артикул	УПР	H=HF мм	B мм	Tmax* мм	l мм	L мм	BF мм	W мм	h мм	Пластины	Винт	Шайба	Ключ	Статус		
SPDED R/L 1212H-S020T15	2.0	12	12	15.0	н.д.	100	12.2	1.8	—	SDGU	AST04W	AS6	H03	○		
SPDED R/L 1616J-S020T08		16	16	8.0	33.0	110	15.1	1.8	4		SSP0516		H04	⊙		
SPDED R/L 1616J-S020T12		16	16	12.0	32.0	110	15.1	1.8	4		SSP0516		H04	⊙		
SPDED R/L 1616K-S020T15		16	16	15.0	н.д.	125	16.2	1.8	—		AST04W	AS6	H03	○		
SPDED R/L 1616J-S020T17		16	16	17.0	37.0	110	15.1	1.8	4		SSP0516		H04	⊙		
SPDED R/L 2020K-S020T08		20	20	8.0	33.0	125	19.1	1.8	—		SSP0520		H04	⊙		
SPDED R/L 2020K-S020T09		20	20	9.0	н.д.	125	20.2	1.8	—		AST04W	AS6	H03	○		
SPDED R/L 2020K-S020T12		20	20	12.0	32.0	125	19.1	1.8	—		SSP0520		H04	⊙		
SPDED R/L 2020K-S020T15		20	20	15.0	н.д.	125	20.2	1.8	—		AST04W	AS6	H03	○		
SPDED R/L 2020K-S020T17		20	20	17.0	37.0	125	19.1	1.8	—		SSP0520		H04	⊙		
SPDED R/L 2020K-S020T20		20	20	20.0	н.д.	125	20.2	1.8	—		AST04W	AS6	H03	○		
SPDED R/L 2525M-S020T08		2.5	25	25	8.0	33.0	150	24.1	1.8		—	SSP0616		H05	⊙	
SPDED R/L 2525M-S020T12			25	25	12.0	32.0	150	24.1	1.8		—	SSP0616		H05	⊙	
SPDED R/L 2525M-S020T17			25	25	17.0	37.0	150	24.1	1.8		—	SDGX	SSP0616	H05	⊙	
SPDED R/L 1616J-S025T12	2.5	16	16	12.0	32.0	110	15.1	2.0	4	SDGX	SSP0516		H04	⊙		
SPDED R/L 2020K-S025T12		20	20	12.0	32.0	125	19.1	2.0	—	SDGX	SSP0520		H04	⊙		
SPDED R/L 2525M-S025T12		25	25	12.0	32.0	150	24.1	2.0	—	SDGC	SSP0616		H05	⊙		
SPDED R/L 1212H-S030T15	3.0	12	12	15.0	н.д.	100	12.4	2.4	—	SDGJ	ASH08120		H04	○		
SPDED R/L 1616J-S030T09		16	16	9.0	32.0	110	14.8	2.4	4		SDEF	SSP0516		H04	⊙	
SPDED R/L 1616J-S030T12		16	16	12.0	32.0	110	14.8	2.4	4			SDGB	SSP0516		H04	⊙
SPDED R/L 1616K-S030T15		16	16	15.0	н.д.	125	16.4	2.4	—				ASH08120		H04	○
SPDED R/L 1616J-S030T20		16	16	20.0	38.5	110	14.8	2.4	—				SSP0516		H04	⊙
SPDED R/L 2020K-S030T09		20	20	9.0	32.0	125	18.8	2.4	—				SSP0520		H04	⊙
SPDED R/L 2020K-S030T12		20	20	12.0	32.0	125	18.8	2.4	—				SSP0520		H04	⊙
SPDED R/L 2020K-S030T20		20	20	20.0	38.5	125	18.8	2.4	—				SSP0520		H04	⊙
SPDED R/L 2020K-S030T25		20	20	25.0	н.д.	125	20.4	2.4	—				ASH08120		H04	○
SPDED R/L 2020K-S030T30		20	20	30.0	н.д.	125	20.4	2.4	—				ASH08120		H04	○
SPDED R/L 2525M-S030T09		25	25	9.0	32.0	150	23.8	2.4	—				SSP0616		H05	⊙
SPDED R/L 2525M-S030T12		25	25	12.0	32.0	150	23.8	2.4	—				SSP0616		H05	⊙
SPDED R/L 2525M-S030T20		25	25	20.0	38.5	150	23.8	2.4	—				SSP0616		H05	⊙
SPDED R/L 2525M-S030T22		25	25	22.0	н.д.	150	25.4	2.4	—				ASH08120		H04	○
SPDED R/L 2525M-S030T25	25	25	25.0	44.5	150	23.8	2.4	—	SSP0616				H05	⊙		
SPDED R/L 2525M-S030T30	25	25	30.0	н.д.	150	25.4	2.4	—	ASH08120		H04		○			
SPDED R/L 3232P-S030T25	32	32	25.0	н.д.	170	32.4	2.4	—	ASH08120		H04	○				

* — изготовление державок с другими параметрами, в том числе с другими значениями размера Tmax возможно по специальному заказу.



ВСЕ ДЕРЖАВКИ СОВМЕСТИМЫ С ПЛАСТИНАМИ TaeguTec

⊙ — стандартная позиция; ○ — продукция изготавливается по спецзаказу потребителя, минимальная партия и сроки — по запросу.

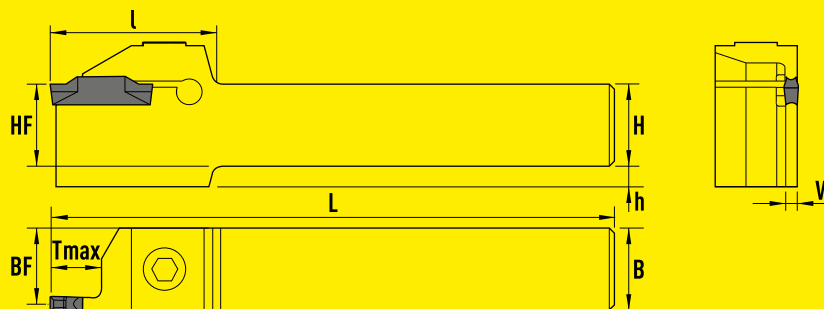
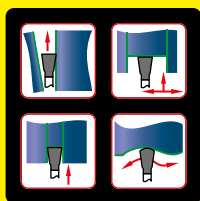

Окончание таблицы

Артикул	УПР	H=HF мм	B мм	Tmax* мм	L мм	L мм	BF мм	W мм	h мм	Пластины	Винт	Шайба	Ключ	Статус	
SPDED R/L 1616J-S040T10	4.0	16	16	10.0	32.0	110	14.5	3.0	4	SDGU	SSP0616		H05	⊙	
SPDED R/L 1616J-S040T15		16	16	15.0	33.0	110	14.5	3.0	4		SSP0616		H05	⊙	
SPDED R/L 1616J-S040T25		16	16	25.0	45.0	110	14.5	3.0	—		SSP0616		H05	⊙	
SPDED R/L 2020K-S040T10		20	20	10.0	32.0	125	18.5	3.0	—		SSP0620		H05	⊙	
SPDED R/L 2020K-S040T15		20	20	15.0	33.0	125	18.5	3.0	—		SSP0620		H05	⊙	
SPDED R/L 2020K-S040T25		20	20	25.0	45.0	125	18.5	3.0	—		SSP0620		H05	⊙	
SPDED R/L 2525M-S040T10		25	25	10.0	32.0	150	23.5	3.0	—		SSP0820		H06	⊙	
SPDED R/L 2525M-S040T15		25	25	15.0	33.0	150	23.5	3.0	—		SSP0820		H06	⊙	
SPDED R/L 2525M-S040T22		25	25	22.0	н.д.	150	25.5	3.0	—		SDGX	ASH08120		H04	○
SPDED R/L 2525M-S040T25		25	25	25.0	45.0	150	23.5	3.0	—		SDGX	SSP0820		H06	⊙
SPDED R/L 2525M-S040T30		25	25	30.0	н.д.	150	25.5	3.0	—		SDGC	ASH08120		H04	○
SPDED R/L 2020K-S050T12		5.0	20	20	12.0	37.0	125	18.1	4.0		—	SDGJ	SSP0620		H05
SPDED R/L 2020K-S050T20	20		20	20.0	37.0	125	18.1	4.0	—	SDGJ	SSP0620		H05	⊙	
SPDED R/L 2525M-S050T12	25		25	12.0	37.0	150	23.1	4.0	—	SDEF	SSP0820		H06	⊙	
SPDED R/L 2525M-S050T20	25		25	20.0	37.0	150	23.1	4.0	—	SDEF	SSP0820		H06	⊙	
SPDED R/L 2525M-S050T25	25		25	25.0	37.0	150	23.1	4.0	—	SDGB	SSP0820		H06	⊙	
SPDED R/L 2525M-S050T32	25		25	32.0	56.0	150	23.0	4.0	—	SDGB	SSP0820		H06	⊙	
SPDED R/L 2020K-S060T12	6.0	20	20	12.0	37.0	125	17.6	5.0	—	SDGB	SSP0820		H06	⊙	
SPDED R/L 2020K-S060T20		20	20	20.0	41.0	125	17.6	5.0	—		SSP0820		H06	⊙	
SPDED R/L 2525M-S060T12		25	25	12.0	37.0	150	22.6	5.0	7		SSP0820		H06	⊙	
SPDED R/L 2525M-S060T20		25	25	20.0	41.0	150	22.6	5.0	7		SSP0820		H06	⊙	
SPDED R/L 2525M-S060T32		25	25	32.0	56.0	150	22.5	5.0	7		SSP0820		H06	⊙	

* — изготовление державок с другими параметрами, в том числе с другими значениями размера T max возможно по специальному заказу.

ДЕРЖАВКИ С КАНАЛАМИ ДЛЯ СОЖ

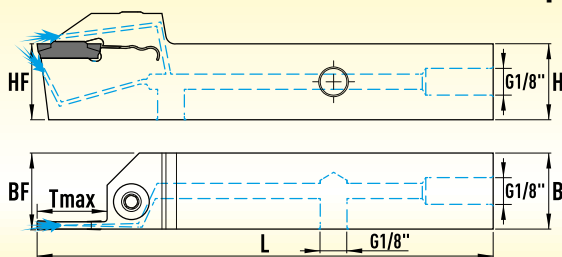
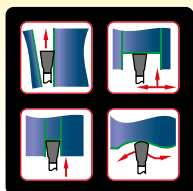

Артикул	УПР	H=HF мм	B мм	Tmax мм	L мм	BF мм	Пластины	Винт	Ключ	Статус
SPDED R/L 2020K-S030T30C	3.0	20	20	30.0	125	20.5	SDGB SDGU SDGX SDGC SDEF	ASH08120	H04	○

ВСЕ ДЕРЖАВКИ СОВМЕСТИМЫ С ПЛАСТИНАМИ TaeguTec

ДЕРЖАВКИ ДЛЯ ТОКАРНЫХ АВТОМАТОВ
ПРОДОЛЬНОГО ТОЧЕНИЯ

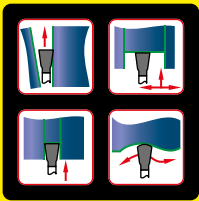

Артикул	УПР	H = HF мм	B мм	Tmax* мм	L мм	BF мм	Пластины	Винт	Ключ	Статус
SPDEAD R/L 1010K-S020T10	2.0	10	10	10	125	10.2	SDGU	AST04W	T15	○
SPDEAD R/L 1212K-S020T12		12	12	12	125	12.2	SDGX			○
SPDEAD R/L 1616K-S020T16		16	16	16	125	16.2	SDGC			○
SPDEAD R/L 1212K-S030T12	3.0	12	12	12	125	12.3	SDGJ			○
SPDEAD R/L 1616K-S030T16		16	16	16	125	16.3	SDEF SDGB			○

* — изготовление державок с другими параметрами, в том числе с другими значениями размера Tmax возможно по специальному заказу.

ЛЕЗВИЯ ОТРЕЗНЫЕ

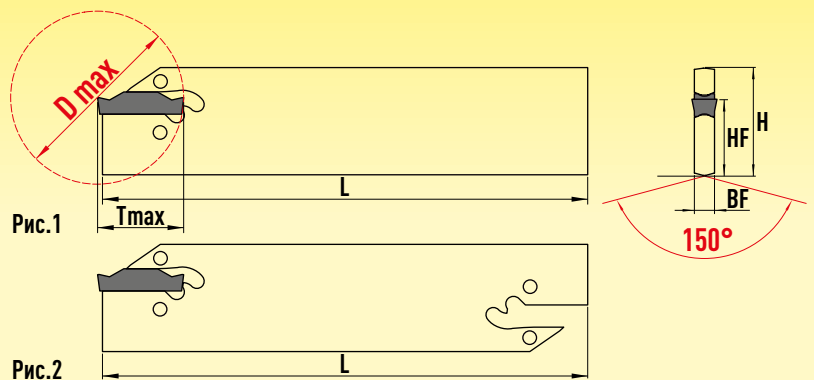
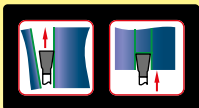

Артикул	Рисунок	УПР	Dmax мм	H мм	HF мм	BF мм	Tmax мм	L мм	Пластины	Ключ	Статус
SCDS26M-S020D040	1	2	40	26	21.4	1.8	20	150	SDGU SDGX SDGC SDGJ SDEF SDGB	SDK33	○
SCDD32M-S020D050	2	2	50	32	24.9	1.8	25				○
SCDS26M-S030D050	1	3	50	26	21.4	2.4	25				○
SCDD32M-S030D100	2	3	100	32	24.9	2.4	50				○
SCDS26M-S040D080	1	4	80	26	21.4	3.2	40				○
SCDD32M-S040D100	2	4	100	32	24.6	3.2	50				○
SCDD32M-S050D120	2	5	120	32	24.6	4.0	60				○



1. Поместить стерженьки ключа в два отверстия на лезвии, вставить до упора, затем повернуть, приподняв прижим, как показано на рисунке.
2. Извлечь пластину из лезвия/вставить пластину в корпус лезвия.
3. Повернуть ключ в исходное положение, вытащить ключ.

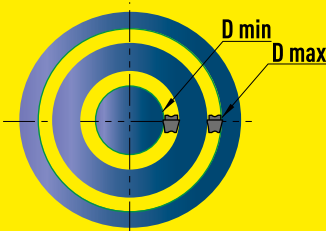
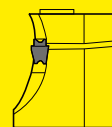
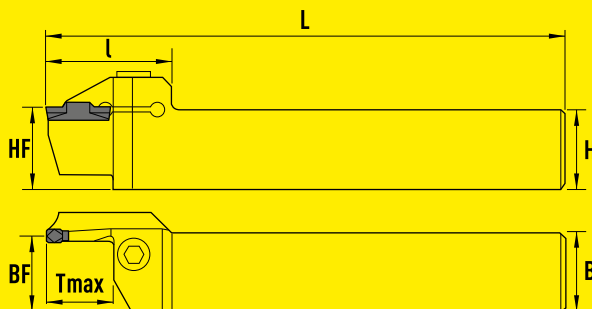
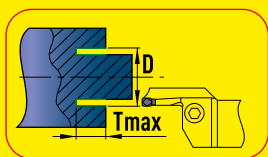
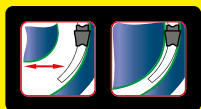

Артикул	УПР	H = HF мм	B мм	T max* мм	L мм	L мм	BF мм	D min мм	D max мм	Пластины	Винт	Ключ	Статус				
SGDED R/L 2020K021-S030T10	3	20	20	10.0	31	125	19.0	21	30	SSP0620	H05	H05	⊙				
SGDED R/L 2020K024-S030T10		20	20	10.0	31	125	19.0	24	35				⊙				
SGDED R/L 2020K029-S030T10		20	20	10.0	31	125	19.0	29	40				⊙				
SGDED R/L 2020K034-S030T10		20	20	10.0	31	125	19.0	34	50				⊙				
SGDED R/L 2020K044-S030T15		20	20	15.0	35	125	19.0	44	70				⊙				
SGDED R/L 2020K064-S030T15		20	20	15.0	35	125	19.0	64	100				⊙				
SGDED R/L 2525M024-S030T10		4	25	25	10.0	38	150	24.0	24	35	SSP0625	H05	H05	⊙			
SGDED R/L 2525M029-S030T10			25	25	10.0	38	150	24.0	29	40				⊙			
SGDED R/L 2525M034-S030T10			25	25	10.0	38	150	24.0	34	50				⊙			
SGDED R/L 2525M044-S030T15			25	25	15.0	38	150	24.0	44	70				⊙			
SGDED R/L 2525M064-S030T15			25	25	15.0	38	150	24.0	64	100				⊙			
SGDED R/L 2020K019-S040T10			20	20	10.0	31	125	18.6	19	30				SDGU SDGX SDGC SDGJ SDEF SDGB	SSP0620	H05	⊙
SGDED R/L 2020K022-S040T10	20		20	10.0	31	125	18.6	22	36	⊙							
SGDED R/L 2020K028-S040T16	20		20	16.0	36	125	18.6	28	42	⊙							
SGDED R/L 2020K034-S040T16	20		20	16.0	36	125	18.6	34	50	⊙							
SGDED R/L 2020K042-S040T16	20		20	16.0	36	125	18.6	42	70	⊙							
SGDED R/L 2020K062-S040T16	20		20	16.0	36	125	18.6	62	120	⊙							
SGDED R/L 2020K112-S040T16	20		20	16.0	36	125	18.6	112	200	⊙							
SGDED R/L 2525M022-S040T10	25	25	10.0	39	150	23.6	22	36	SSP0625	H05	H05	⊙					
SGDED R/L 2525M028-S040T20	25	25	20.0	39	150	23.6	28	42				⊙					
SGDED R/L 2525M034-S040T20	25	25	20.0	39	150	23.6	34	50				⊙					
SGDED R/L 2525M042-S040T20	25	25	20.0	39	150	23.6	42	70				⊙					
SGDED R/L 2525M062-S040T20	25	25	20.0	39	150	23.6	62	120				⊙					
SGDED R/L 2525M112-S040T20	25	25	20.0	39	150	23.6	112	200				⊙					
SGDED R/L 2525M200-S040T20	25	25	20.0	39	150	23.6	200	∞				⊙					
SGDED R/L 2525M050-S050T15	5	25	25	15.0	41	150	23.1	50				80	SSP0820	H06	H06	⊙	
SGDED R/L 2525M050-S050T25		25	25	25.0	49	150	23.1	50				80				⊙	
SGDED R/L 2525M070-S050T15		25	25	15.0	41	150	23.1	70				110				⊙	
SGDED R/L 2525M070-S050T25		25	25	25.0	49	150	23.1	70				110				⊙	
SGDED R/L 2525M100-S050T25		25	25	25.0	49	150	23.1	100				150				⊙	
SGDED R/L 2525M140-S050T25		25	25	25.0	49	150	23.1	140	200	⊙							
SGDED R/L 2525M200-S050T25		25	25	25.0	49	150	23.1	200	∞	⊙							
SGDED R/L 2525M048-S060T25		6	25	25	25.0	49	150	22.6	48	70	SSP0820	H06				H06	⊙
SGDED R/L 2525M058-S060T25			25	25	25.0	49	150	22.6	58	100							⊙
SGDED R/L 2525M088-S060T25			25	25	25.0	49	150	22.6	88	180							⊙
SGDED R/L 2525M168-S060T25			25	25	25.0	49	150	22.6	168	400							⊙
SGDED R/L 2525M400-S060T25			25	25	25.0	49	150	22.6	400	∞							⊙
SGDED R/L 2525M400-S060T25	25		25	25.0	49	150	22.6	400	∞	⊙							

* — изготовление державок с другими параметрами, в том числе с другими значениями размера T max возможно по специальному заказу.

ВСЕ ДЕРЖАВКИ СОВМЕСТИМЫ С ПЛАСТИНАМИ TaeguTec

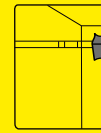
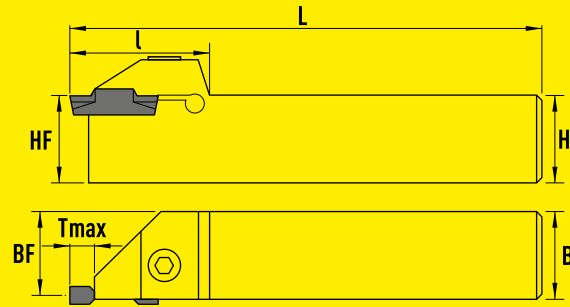
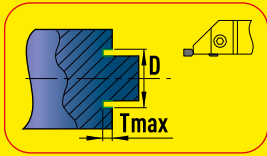

Артикул	УПР	H = HF мм	B мм	T max* мм	L мм	L мм	BF мм	Пластины	Винт	Ключ	Статус
SGDED R/L 1616J018-S234T04	2/3/4	16	16	4.8	33	110	14.6	SDGU	SSP0616	H05	☉
SGDED R/L 2020K018-S234T04	2/3/4	20	20	4.8	33	125	18.6	SDGX	SSP0620		☉
SGDED R/L 2525M018-S234T04	2/3/4	25	25	4.8	33	150	23.6	SDGC	SSP0625		☉
SGDED R/L 2020K020-S56T04	5/6	20	20	4.8	37	125	17.6	SDGJ	SSP0620		☉
SGDED R/L 2525M020-S56T04	5/6	25	25	4.8	37	150	22.6	SDEF	SSP0625		☉
								SDGB	SSP0625		☉

* — изготовление державок с другими параметрами, в том числе с другими значениями размера T max возможно по специальному заказу.

Начальный минимальный диаметр торцевой канавки для различных типов и размеров пластин

D min	W	D min мм				
		SDGU	SDGX	SDGC/SDGJ	SDEF	SDGB
	3	18	18	54	44	41
	4	18	18	34	42	36
	5	20	20	—	50	54
	6	18	18	—	48	48

ВСЕ ДЕРЖАВКИ СОВМЕСТИМЫ С ПЛАСТИНАМИ TaeguTec

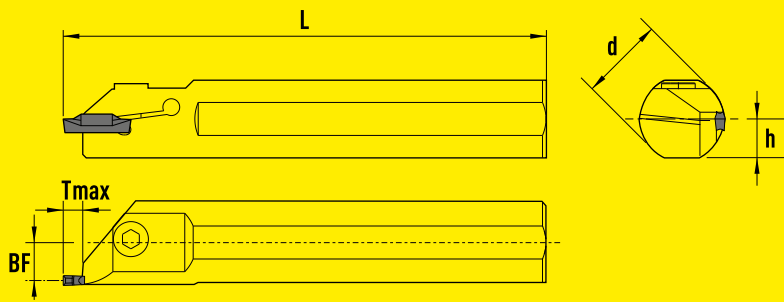
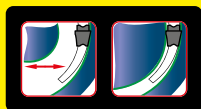

Артикул	УПР	d мм	BF мм	T max* мм	L мм	h мм	Пластины	Винт	Ключ	Статус
SGDND R/L 2625R020-S34T05	3, 4	25	11.3	5.5	200	11.5	SDGU SDGX SDGC SDGJ SDEF SDGB	SSP0620	H05	☉
SGDND R/L 3332S018-S34T05	3, 4	32	14.8	5.5	250	15.0		SSP0625		☉
SGDND R/L 2625R020-S56T05	5, 6	25	10.3	5.5	200	11.5		SSP0620		☉
SGDND R/L 3332S018-S56T05	5, 6	32	13.8	5.5	250	15.0		SSP0625		☉

* — изготовление державок с другими параметрами, в том числе с другими значениями размера T max возможно по специальному заказу.

РАСТАЧИВАНИЕ	ОБРАБОТКА ТОРЦЕВЫХ КАНАВОК	ОБРАБОТКА КОЛЬЦЕВЫХ КАНАВОК
$B_{min} = BF + D/2 + S/2 + 2G$	$D_{min} = 2BF + D + S - B + 2G$	$P_{min} = 2BF + D - S - B + 2G$

W	B min мм		D min мм		D max мм
	d = 25	d = 32	SDGU	SDGB	
3	26.3	33.3	20	41	∞
4	26.8	33.8	18	36	
5	26.3	33.3	20	54	
6	26.8	33.8	18	54	

ВСЕ ДЕРЖАВКИ СОВМЕСТИМЫ С ПЛАСТИНАМИ TaeguTec

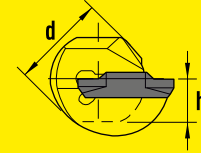
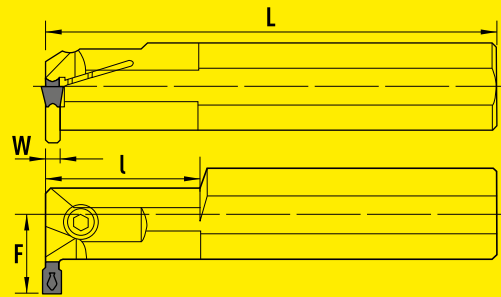
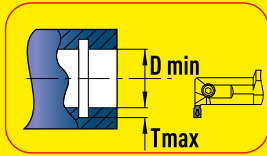

Артикул	УПР	d мм	F мм	T max* мм	l мм	L мм	D min мм	W мм	h мм	Пластины	Винт	Ключ	Статус
SGDND R/L 2516K-S020T08	2.0	16	16.5	8.5	—	125	25	1.8	7.5	SDGU SDGX SDGC SDGJ SDEF SDGB	SSP0512	H04	⊙
SGDND R/L 2520N-S020T06	2.0	20	15.8	6.0	40	160	25	1.6	9.0		SSP0516		⊙
SGDND R/L 2525R-S020T05	2.0	25	17.5	5.0	40	200	25	1.6	11.5		SSP0520		⊙
SGDND R/L 2520N-S025T06	2.5	20	15.8	6.0	40	160	25	2.0	9.0		SSP0516		⊙
SGDND R/L 2525R-S025T05	2.5	25	17.5	5.0	40	200	25	2.0	11.5		SSP0520		⊙
SGDND R/L 3132S-S025T04	2.5	32	19.8	4.7	60	250	31	2.0	14.0		SSP0525		⊙
SGDND R/L 2520N-S030T06	3.0	20	15.8	6.0	40	160	25	2.1	9.0		SSP0516		⊙
SGDND R/L 2525R-S030T05	3.0	25	17.5	5.1	40	200	25	2.1	11.5		SSP0520		⊙
SGDND R/L 3132S-S030T04	3.0	32	19.8	4.7	60	250	31	2.1	14.0		SSP0525		⊙
SGDND R/L 2520N-S040T06	4.0	20	15.8	6.0	40	160	25	2.9	9.0		SSP0516		⊙
SGDND R/L 2525R-S040T05	4.0	25	17.5	5.2	40	200	25	2.9	11.5		SSP0520		⊙
SGDND R/L 3132S-S040T04	4.0	32	20.8	4.7	60	250	31	2.9	14.0		SSP0525		⊙
SGDND R/L 4032S-S040T12	4.0	32	22	12.0	64	250	40	4.0			SSP0525		○
SGDND R/L 5240T-S040T16	4.0	40	30	16.0	80	300	52	4.0			SSP0525		○

* — изготовление державок с другими параметрами, в том числе с другими значениями размера T max возможно по специальному заказу.

Минимальный диаметр отверстия при обработке внутренних радиальных канавок разными типами и размерами пластин

D min	W	D min мм				
		SDGU	SDGX	SDGC/SDGJ	SDEF	SDGB
2	24	24	24	40	—	41
2.5	24	24	24	—	—	—
3	24	24	24	50	40	38
4	21	21	21	50	40	38
5	30	30	30	60	50	43
6	31	31	31	60	50	46
—	—	—	—	—	62	56

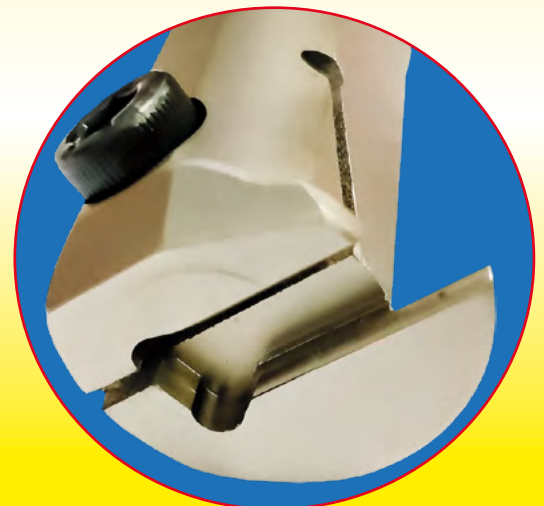
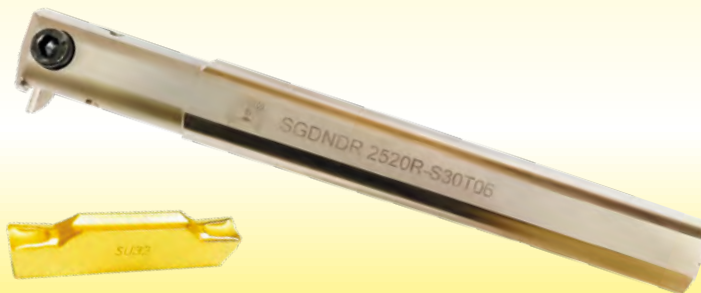



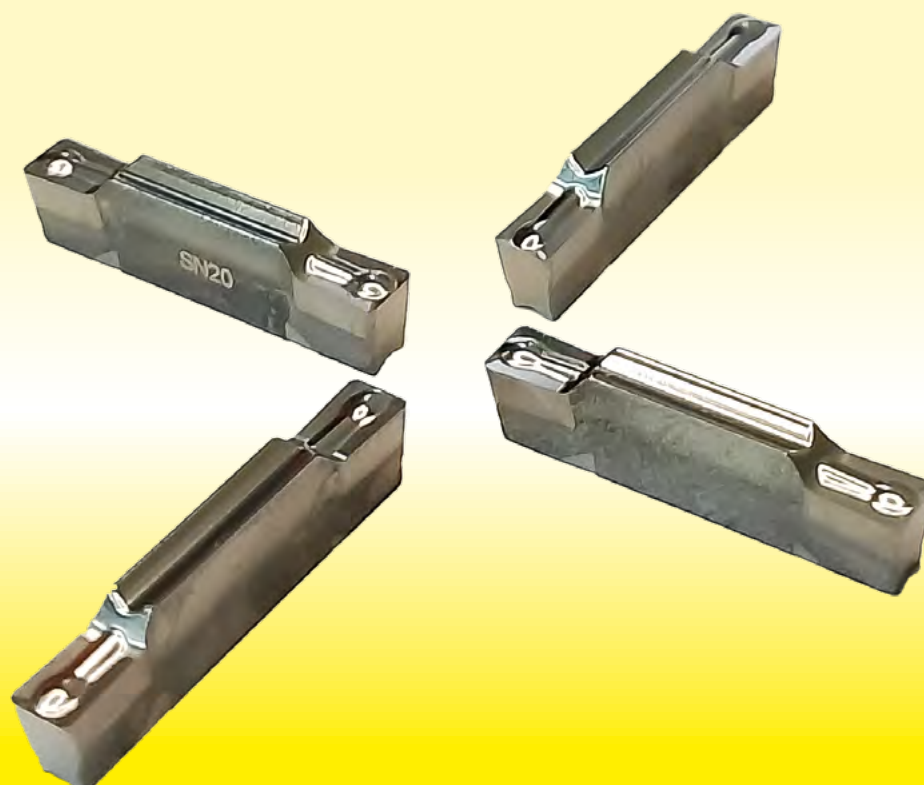

ВСЕ ДЕРЖАВКИ СОВМЕСТИМЫ С ПЛАСТИНАМИ TaeguTec

	МАРКА СПЛАВА	ОПИСАНИЕ								Vc м/мин		
			05	10	15	20	25	30	35		40	
С ПOKPЫТИЕМ	SU32	Универсальный твердый сплав с многослойным покрытием TiAlN+TiN. Используется для черновой и получистовой обработки сталей и нержавеющей сталей. Высокая износостойкость сочетается с хорошей ударной вязкостью.	P									120-200
			M									80-180
			K									
			N									
			S									
			H									
	SK72	Мелкозернистый твердый сплав с износостойким покрытием. В основном используется для общей обработки чугунов.		05	10	15	20	25	30	35	40	
			P									
			M									
			K									150-200
			N									
			S									
	RMS30	Высококачественный высокопроизводительный сплав для обработки труднообрабатываемых материалов. Используется для черновой и получистовой обработки. Хорошо выдерживает нестабильные условия резания.		05	10	15	20	25	30	35	40	
			P									120-200
			M									80-150
			K									
N												
S											50-80	
RU93	Универсальный мелкозернистый твердый сплав с износостойким покрытием. Обработка сталей, нержавеющей сталей, жаропрочных сплавов.		05	10	15	20	25	30	35	40		
		P									100-180	
		M									80-120	
		K										
		N										
		S									40-80	
БЕЗ ПOKPЫТИЯ	SN20	Износостойкий твердый сплав без покрытия. В основном предназначен для чистовой и получистовой обработки цветных металлов и неметаллов.		05	10	15	20	25	30	35	40	
			P									
			M									
			K									
			N									300-800
			S									

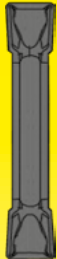

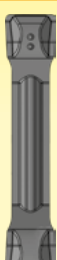
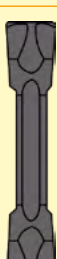
ОПИСАНИЕ ГЕОМЕТРИЙ			Наружная обработка			Обработка торцов		Внутренняя обработка		Контурная обработка
			Отрезание	Нарезание	Точение	Нарезание	Точение	Нарезание	Точение	
SDGU		<p>Лучший выбор для отрезки и нарезания канавок общего назначения. Отличная способность контролировать стружку. Плоская режущая кромка типа U. Подходит для легкой и средней обработки. Применяется для наружной и внутренней обработки, и обработки торцов.</p>	●	●	●	●	●	●	●	
SDGX		<p>Лучший выбор для отрезки и нарезания канавок общего назначения. Отличная способность контролировать стружку. Плоская режущая кромка типа U. Подходит для легкой и средней обработки. Применяется для наружной и внутренней обработки, и обработки торцов.</p>	●	●	●	●	●	●	●	
SDGC		<p>Отрезка и обработка канавок. Лучший выбор для обработки материалов с высокой твердостью и ударной вязкостью. Общее использование: для стали/легированной стали, возможно применение по нержавеющей стали. Высокоточная режущая кромка для обработки со средней и большой подачей.</p>	●	●						
NEW SDGJ		<p>Для мягких материалов, отрезки труб, обработки малых диаметров и тонкостенных деталей. Низкие силы резания и хорошее качество обработанной поверхности. Улучшенная прямолинейность. Обработка в режиме малых и средних скоростей.</p>	●	●						
SDEF		<p>Отрезка и обработка канавок из стали/легированной стали/нержавеющей стали. Шлифованная поверхность, высокая точность. Т-образный стружколом, удаление стружки в различных направлениях. Подходит для отрезки и обработки канавок с низкой и средней подачей.</p>	●	●	●	●	●	●	●	
SDGB		<p>Точение, обработка канавок и профилирование. Т-образный стружколом, удаление стружки в различных направлениях. Подходит для обработки канавок и профилирования со средней и высокой подачей.</p>		●	●			●	●	●

Артикул	W±0.05	S	L	h	r	Точение		Нарезание канавок	Сплавы с покрытием				без покрытия		
						Поддача мм/об	Глубина рез. мм		SU32	SK72	RMS30	RU93			
														SN20	
	SDGU2.00	2.0	1.7	20.0	4.7	0.3	0.12-0.18	0.4-1.2	0.03-0.18	●					
	SDGU2.50	2.5	2.2	20.0	4.7	0.3	0.15-0.19	0.4-1.8	0.04-0.11	●					
	SDGU3.00	3.0	2.2	20.0	4.7	0.3	0.15-0.19	0.4-1.8	0.04-0.11	●					
	SDGU4.00	4.0	3.0	20.0	4.7	0.4	0.18-0.24	0.5-2.4	0.09-0.15	●					
	SDGU5.00	5.0	4.0	25.0	5.2	0.4	0.20-0.30	0.5-3.0	0.11-0.20	●					
	SDGU6.00	6.0	5.0	25.0	5.2	0.8	0.22-0.36	0.1-0.4	0.13-0.23	●					
	SDGX3.00E0.40	3.0	2.2	20.0	4.7	0.4	0.17-0.20	0.5-1.8	0.06-0.18	●	●				
	SDGX4.00E0.40	4.0	3.0	20.0	4.7	0.4	0.20-0.27	0.5-2.4	0.07-0.20	●	●				
	SDGX4.00E0.80	4.0	3.0	20.0	4.7	0.8	0.22-0.27	1.0-2.4	0.07-0.20	●	●				
	SDGX5.00E0.40	5.0	4.0	25.0	5.2	0.4	0.22-0.32	0.5-3.0	0.08-0.23	●	●				
	SDGX5.00E0.80	5.0	4.0	25.0	5.2	0.8	0.25-0.37	1.0-3.0	0.08-0.23	●	●				
	SDGX6.00E0.40	6.0	5.0	25.0	5.2	0.4	0.25-0.38	0.5-3.6	0.12-0.35	●	●				
	SDGX6.00E0.80	6.0	5.0	25.0	5.2	0.8	0.26-0.42	1.0-3.6	0.12-0.35	●	●				
	SDGC2.00E0.20	2.0	1.7	20.0	4.7	0.2	0.17-0.20	0.5-1.8	0.05-0.18	●	●	●	●		
	SDGC3.00E0.20	3.0	2.4	20.0	4.7	0.2	0.20-0.27	0.5-2.4	0.07-0.25			●	●		
	SDGC4.00E0.30	4.0	3.0	20.0	4.7	0.3	0.22-0.27	1.0-2.4	0.08-0.30			●	●		
	SDGC5.00E0.30	5.0	4.0	25.0	5.2	0.3	0.20-0.27	0.5-2.4	0.09-0.35	●	●		●		
	SDGC6.00E0.30	6.0	5.0	25.0	5.2	0.3	0.22-0.27	1.0-2.4	0.12-0.40	●	●				
	SDGJ2.00	2.0	1.7	20.0	4.7	0.2	0.05-0.10	—	0.05-0.10			●	●		
	SDGJ3.00	3.0	2.4	20.0	4.7	0.2	0.06-0.12	—	0.06-0.12			●	●		
	SDGJ4.00	4.0	3.0	20.0	4.7	0.3	0.07-0.20	—	0.07-0.20			●	●		
	SDEF3.00E0.40	3.0	2.2	20.0	4.7	0.4	0.15-0.22	0.5-2.0	0.07-0.15	●		●	●	●	
	SDEF4.00E0.40	4.0	3.0	20.0	4.7	0.4	0.18-0.30	0.5-2.4	0.09-0.18	●		●	●	●	
	SDEF4.00E0.80	4.0	3.0	20.0	4.7	0.8	0.18-0.30	1.0-2.4	0.09-0.18	●		●	●	●	
	SDEF5.00E0.40	5.0	4.0	25.0	5.2	0.4	0.20-0.35	0.5-2.3	0.11-0.20	●				●	
	SDEF5.00E0.80	5.0	4.0	25.0	5.2	0.8	0.23-0.35	1.0-3.0	0.11-0.20	●				●	
	SDEF6.00E0.80	6.0	5.0	25.0	5.2	0.8	0.24-0.42	1.0-3.6	0.13-0.30	●				●	
	SDEF6.00E1.20	6.0	5.0	25.0	5.2	1.2	0.24-0.42	1.3-3.6	0.13-0.30	●				●	
	SDEF8.00E0.80	8.0	6.0	30.0	6.4	0.8	0.30-0.56	1.0-4.8	0.15-0.40	●				●	
	SDEF8.00E1.20	8.0	6.0	30.0	6.4	1.2	0.30-0.56	1.3-4.8	0.15-0.40	●				●	
	SDGB2.00-1.00	2.0	1.7	20.0	4.7	1.0	0.10-0.25	0.0-1.0	0.05-0.15	●					
	SDGB3.00-1.50	3.0	2.2	20.0	4.7	1.5	0.15-0.28	0.0-1.5	0.08-0.18	●					
	SDGB4.00-2.00	4.0	3.0	20.0	4.7	2.0	0.18-0.35	0.0-2.0	0.10-0.20	●					
	SDGB5.00-2.50	5.0	4.0	25.0	5.2	2.5	0.20-0.42	0.0-2.5	0.12-0.23	●					
	SDGB6.00-3.00	6.0	5.0	25.0	5.2	3.0	0.25-0.54	0.0-3.0	0.15-0.27	●					
	SDGB8.00-4.00	8.0	6.0	30.0	6.4	4.0	0.30-0.67	0.0-4.0	0.18-0.35	●					





РАЗДЕЛ 5. СВЁРЛА

5.1. СВЁРЛА МОНОЛИТНЫЕ ТВЕРДОСПЛАВНЫЕ



СВЕРЛА ТВЕРДОСПЛАВНЫЕ УНИВЕРСАЛЬНЫЕ. ОБЩАЯ ОБРАБОТКА МАТЕРИАЛОВ ГРУПП Р, М, К, S, Н

СЕРИЯ WD003



3D

h8

130°

140°

AlTiCrN

P

M

K

N

S

H

D < 3

D ≥ 3

Артикул	Dмм	lмм	Lмм	dмм
WD003D003003	0.30	2	38	3
WD003D005003	0.50	3	38	3
WD003D006003	0.60	3	38	3
WD003D007003	0.70	3	38	3
WD003D008003	0.80	4	38	3
WD003D009003	0.90	4	38	3
WD003D010003	1.00	4	38	3
WD003D011003	1.10	6	38	3
WD003D012003	1.20	6	38	3
WD003D013003	1.30	6	38	3
WD003D014003	1.40	6	38	3
WD003D015003	1.50	6	38	3
WD003D016003	1.60	8	38	3
WD003D017003	1.70	8	38	3
WD003D018003	1.80	10	50	3
WD003D019003	1.90	10	50	3
WD003D020003	2.00	10	50	3
WD003D021003	2.10	12	50	3
WD003D022003	2.20	12	50	3
WD003D023003	2.30	12	50	3
WD003D024003	2.40	12	50	3
WD003D025003	2.50	16	50	3
WD003D026003	2.60	16	50	3
WD003D027003	2.70	16	50	3
WD003D028003	2.80	16	50	3
WD003D029003	2.90	16	50	3
WD003D030004	3.00	20	60	4
WD003D031004	3.10	20	60	4
WD003D032004	3.20	20	60	4
WD003D033004	3.30	20	60	4
WD003D034004	3.40	20	60	4
WD003D035004	3.50	20	60	4
WD003D036004	3.60	20	60	4
WD003D037004	3.70	20	60	4
WD003D038004	3.80	24	60	4
WD003D039004	3.90	24	60	4
WD003D040004	4.00	24	60	4
WD003D030006	3.00	20	62	6
WD003D031006	3.10	20	62	6
WD003D032006	3.20	20	62	6
WD003D032306	3.23	20	62	6
WD003D033006	3.30	20	62	6
WD003D034006	3.40	20	62	6
WD003D035006	3.50	20	62	6
WD003D036006	3.60	20	62	6
WD003D037006	3.70	20	62	6
WD003D038006	3.80	24	66	6
WD003D039006	3.90	24	66	6
WD003D040006	4.00	24	66	6
WD003D041006	4.10	24	66	6
WD003D042006	4.20	24	66	6
WD003D043006	4.30	24	66	6
WD003D044006	4.40	24	66	6
WD003D045006	4.50	24	66	6
WD003D046006	4.60	24	66	6

Артикул	Dмм	lмм	Lмм	dмм
WD003D047006	4.70	24	66	6
WD003D048006	4.80	28	66	6
WD003D049006	4.90	28	66	6
WD003D050006	5.00	28	66	6
WD003D051006	5.10	28	66	6
WD003D052006	5.20	28	66	6
WD003D053006	5.30	28	66	6
WD003D054006	5.40	28	66	6
WD003D055006	5.50	28	66	6
WD003D056006	5.60	28	66	6
WD003D057006	5.70	28	66	6
WD003D058006	5.80	28	66	6
WD003D059006	5.90	28	66	6
WD003D060006	6.00	28	66	6
WD003D061008	6.10	34	79	8
WD003D062008	6.20	34	79	8
WD003D063008	6.30	34	79	8
WD003D064008	6.40	34	79	8
WD003D065008	6.50	34	79	8
WD003D066008	6.60	34	79	8
WD003D067008	6.70	34	79	8
WD003D068008	6.80	34	79	8
WD003D069008	6.90	34	79	8
WD003D070008	7.00	34	79	8
WD003D071008	7.10	41	79	8
WD003D072008	7.20	41	79	8
WD003D073008	7.30	41	79	8
WD003D074008	7.40	41	79	8
WD003D075008	7.50	41	79	8
WD003D076008	7.60	41	79	8
WD003D077008	7.70	41	79	8
WD003D078008	7.80	41	79	8
WD003D079008	7.90	41	79	8
WD003D080008	8.00	41	79	8
WD003D081010	8.10	47	89	10
WD003D082010	8.20	47	89	10
WD003D083010	8.30	47	89	10
WD003D084010	8.40	47	89	10
WD003D085010	8.50	47	89	10
WD003D086010	8.60	47	89	10
WD003D087010	8.70	47	89	10
WD003D088010	8.80	47	89	10
WD003D089010	8.90	47	89	10
WD003D090010	9.00	47	89	10
WD003D091010	9.10	47	89	10
WD003D092010	9.20	47	89	10
WD003D093010	9.30	47	89	10
WD003D094010	9.40	47	89	10
WD003D095010	9.50	47	89	10
WD003D096010	9.60	47	89	10
WD003D097010	9.70	47	89	10
WD003D098010	9.80	47	89	10
WD003D099010	9.90	47	89	10
WD003D100010	10.00	47	89	10
WD003D101012	10.10	55	102	12

Артикул	Dмм	lмм	Lмм	dмм
WD003D102012	10.20	55	102	12
WD003D103012	10.30	55	102	12
WD003D104012	10.40	55	102	12
WD003D105012	10.50	55	102	12
WD003D106012	10.60	55	102	12
WD003D107012	10.70	55	102	12
WD003D108012	10.80	55	102	12
WD003D109012	10.90	55	102	12
WD003D110012	11.00	55	102	12
WD003D111012	11.10	55	102	12
WD003D112012	11.20	55	102	12
WD003D113012	11.30	55	102	12
WD003D114012	11.40	55	102	12
WD003D115012	11.50	55	102	12
WD003D116012	11.60	55	102	12
WD003D117012	11.70	55	102	12
WD003D118012	11.80	55	102	12
WD003D119012	11.90	55	102	12
WD003D120012	12.00	55	102	12
WD003D121014	12.10	60	107	14
WD003D122014	12.20	60	107	14
WD003D123014	12.30	60	107	14
WD003D124014	12.40	60	107	14
WD003D125014	12.50	60	107	14
WD003D126014	12.60	60	107	14
WD003D128014	12.80	60	107	14
WD003D129014	12.90	60	107	14
WD003D130014	13.00	60	107	14
WD003D132014	13.20	60	107	14
WD003D133014	13.30	60	107	14
WD003D135014	13.50	60	107	14
WD003D137014	13.70	60	107	14
WD003D138014	13.80	60	107	14
WD003D140014	14.00	60	107	14
WD003D142016	14.20	65	115	16
WD003D143016	14.30	65	115	16
WD003D144016	14.40	65	115	16
WD003D145016	14.50	65	115	16
WD003D147016	14.70	65	115	16
WD003D150016	15.00	65	115	16
WD003D152016	15.20	65	115	16
WD003D155016	15.50	65	115	16
WD003D156016	15.60	65	115	16
WD003D157016	15.70	65	115	16
WD003D158016	15.80	65	115	16
WD003D160016	16.00	65	115	16
WD003D165018	16.50	73	123	18
WD003D170018	17.00	73	123	18
WD003D175018	17.50	73	123	18
WD003D180018	18.00	73	123	18
WD003D185020	18.50	79	131	20
WD003D190020	19.00	79	131	20
WD003D195020	19.50	79	131	20
WD003D200020	20.00	79	131	20

Свёрла с размерами, отсутствующими в таблице, изготавливаются по запросу потребителя

СЕРИЯ WD011

5D

h8



AlTiCrN

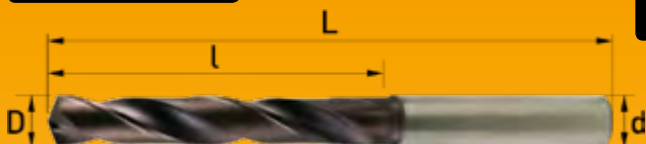

Артикул	Dмм	Lмм	Lмм	dмм
WD011D0300	3.00	28	66	6
WD011D0325	3.25	28	66	6
WD011D0330	3.30	28	66	6
WD011D0340	3.40	28	66	6
WD011D0350	3.50	28	66	6
WD011D0357	3.57	28	66	6
WD011D0360	3.60	28	66	6
WD011D0370	3.70	28	66	6
WD011D0380	3.80	36	74	6
WD011D0390	3.90	36	74	6
WD011D0400	4.00	36	74	6
WD011D0410	4.10	36	74	6
WD011D0420	4.20	36	74	6
WD011D0430	4.30	36	74	6
WD011D0440	4.40	36	74	6
WD011D0450	4.50	36	74	6
WD011D0460	4.60	36	74	6
WD011D0470	4.70	36	74	6
WD011D0480	4.80	44	82	6
WD011D0490	4.90	44	82	6
WD011D0500	5.00	44	82	6
WD011D0510	5.10	44	82	6
WD011D0520	5.20	44	82	6
WD011D0530	5.30	44	82	6
WD011D0540	5.40	44	82	6
WD011D0550	5.50	44	82	6
WD011D0555	5.55	44	82	6
WD011D0560	5.60	44	82	6
WD011D0570	5.70	44	82	6
WD011D0580	5.80	44	82	6
WD011D0590	5.90	44	82	6
WD011D0600	6.00	44	82	6
WD011D0610	6.10	53	91	8
WD011D0620	6.20	53	91	8
WD011D0630	6.30	53	91	8
WD011D0640	6.40	53	91	8
WD011D0650	6.50	53	91	8
WD011D0660	6.60	53	91	8
WD011D0670	6.70	53	91	8
WD011D0680	6.80	53	91	8
WD011D0690	6.90	53	91	8
WD011D0700	7.00	53	91	8
WD011D0710	7.10	53	91	8
WD011D0720	7.20	53	91	8
WD011D0730	7.30	53	91	8
WD011D0740	7.40	53	91	8

Артикул	Dмм	Lмм	Lмм	dмм
WD011D0750	7.50	53	91	8
WD011D0760	7.60	53	91	8
WD011D0770	7.70	53	91	8
WD011D0780	7.80	53	91	8
WD011D0790	7.90	53	91	8
WD011D0800	8.00	53	91	8
WD011D0810	8.10	61	103	10
WD011D0820	8.20	61	103	10
WD011D0830	8.30	61	103	10
WD011D0840	8.40	61	103	10
WD011D0850	8.50	61	103	10
WD011D0860	8.60	61	103	10
WD011D0870	8.70	61	103	10
WD011D0880	8.80	61	103	10
WD011D0890	8.90	61	103	10
WD011D0900	9.00	61	103	10
WD011D0910	9.10	61	103	10
WD011D0920	9.20	61	103	10
WD011D0930	9.30	61	103	10
WD011D0940	9.40	61	103	10
WD011D0950	9.50	61	103	10
WD011D0960	9.60	61	103	10
WD011D0970	9.70	61	103	10
WD011D0980	9.80	61	103	10
WD011D0990	9.90	61	103	10
WD011D1000	10.00	61	103	10
WD011D1010	10.10	71	118	12
WD011D1020	10.20	71	118	12
WD011D1030	10.30	71	118	12
WD011D1040	10.40	71	118	12
WD011D1050	10.50	71	118	12
WD011D1060	10.60	71	118	12
WD011D1070	10.70	71	118	12
WD011D1080	10.80	71	118	12
WD011D1090	10.90	71	118	12
WD011D1100	11.00	71	118	12
WD011D1110	11.10	71	118	12
WD011D1120	11.20	71	118	12
WD011D1130	11.30	71	118	12
WD011D1140	11.40	71	118	12
WD011D1150	11.50	71	118	12
WD011D1160	11.60	71	118	12
WD011D1170	11.70	71	118	12
WD011D1180	11.80	71	118	12
WD011D1190	11.90	71	118	12

Артикул	Dмм	Lмм	Lмм	dмм
WD011D1200	12.00	71	118	12
WD011D1210	12.10	77	124	14
WD011D1220	12.20	77	124	14
WD011D1230	12.30	77	124	14
WD011D1240	12.40	77	124	14
WD011D1250	12.50	77	124	14
WD011D1260	12.60	77	124	14
WD011D1280	12.80	77	124	14
WD011D1290	12.90	77	124	14
WD011D1300	13.00	77	124	14
WD011D1310	13.10	77	124	14
WD011D1330	13.30	77	124	14
WD011D1340	13.40	77	124	14
WD011D1350	13.50	77	124	14
WD011D1360	13.60	77	124	14
WD011D1370	13.70	77	124	14
WD011D1380	13.80	77	124	14
WD011D1390	13.90	77	124	14
WD011D1400	14.00	77	124	14
WD011D1410	14.10	83	133	16
WD011D1420	14.20	83	133	16
WD011D1430	14.30	83	133	16
WD011D1440	14.40	83	133	16
WD011D1450	14.50	83	133	16
WD011D1460	14.60	83	133	16
WD011D1470	14.70	83	133	16
WD011D1480	14.80	83	133	16
WD011D1490	14.90	83	133	16
WD011D1500	15.00	83	133	16
WD011D1510	15.10	83	133	16
WD011D1520	15.20	83	133	16
WD011D1530	15.30	83	133	16
WD011D1540	15.40	83	133	16
WD011D1550	15.50	83	133	16
WD011D1560	15.60	83	133	16
WD011D1570	15.70	83	133	16
WD011D1580	15.80	83	133	16
WD011D1590	15.90	83	133	16
WD011D1600	16.00	83	133	16
WD011D1650	16.50	93	143	18
WD011D1700	17.00	93	143	18
WD011D1750	17.50	93	143	18
WD011D1800	18.00	93	143	18
WD011D2000	20.00	101	153	20



СВЕРЛА С ПЛОСКИМ ТОРЦОМ 180°. ОБЩАЯ ОБРАБОТКА МАТЕРИАЛОВ ГРУПП Р, М, К

СЕРИЯ WD008

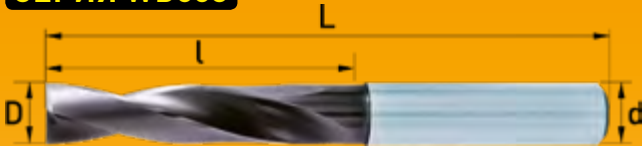

3D

h8



ALTiSiN



Артикул	Dмм	lмм	Lмм	dмм
WD008D0220.4	2.20	13	60	4
WD008D0260.4	2.60	15	60	4
WD008D0270.4	2.70	15	60	4
WD008D0300.4	3.00	20	60	4
WD008D0310.4	3.10	20	60	4
WD008D0320.4	3.20	20	60	4
WD008D0330.4	3.30	20	60	4
WD008D0340.4	3.40	20	60	4
WD008D0350.4	3.50	20	60	4
WD008D0360.4	3.60	20	60	4
WD008D0370.4	3.70	20	60	4
WD008D0380.4	3.80	24	60	4
WD008D0390.4	3.90	24	60	4
WD008D0300.6	3.00	20	62	6
WD008D0310.6	3.10	20	62	6
WD008D0320.6	3.20	20	62	6
WD008D0330.6	3.30	20	62	6
WD008D0340.6	3.40	20	62	6
WD008D0350.6	3.50	20	62	6
WD008D0360.6	3.60	20	62	6
WD008D0370.6	3.70	20	62	6
WD008D0380.6	3.80	24	66	6
WD008D0390.6	3.90	24	66	6
WD008D0400.6	4.00	24	66	6
WD008D0410.6	4.10	24	66	6
WD008D0420.6	4.20	24	66	6
WD008D0430.6	4.30	24	66	6
WD008D0440.6	4.40	24	66	6
WD008D0450.6	4.50	24	66	6
WD008D0460.6	4.60	24	66	6
WD008D0470.6	4.70	24	66	6
WD008D0480.6	4.80	28	66	6
WD008D0490.6	4.90	28	66	6
WD008D0500.6	5.00	28	66	6
WD008D0510.6	5.10	28	66	6
WD008D0520.6	5.20	28	66	6
WD008D0530.6	5.30	28	66	6
WD008D0450.6	5.40	28	66	6
WD008D0550.6	5.50	28	66	6
WD008D0560.6	5.60	28	66	6
WD008D0570.6	5.70	28	66	6
WD008D0580.6	5.80	28	66	6
WD008D0590.6	5.90	28	66	6
WD008D0600.6	6.00	28	66	6
WD008D0610.8	6.10	34	79	8
WD008D0620.8	6.20	34	79	8
WD008D0630.8	6.30	34	79	8
WD008D0635.8	6.35	34	79	8
WD008D0640.8	6.40	34	79	8
WD008D0650.8	6.50	34	79	8
WD008D0660.8	6.60	34	79	8
WD008D0670.8	6.70	34	79	8
WD008D0680.8	6.80	34	79	8
WD008D0690.8	6.90	34	79	8
WD008D0700.8	7.00	34	79	8

Артикул	Dмм	lмм	Lмм	dмм
WD008D0710.8	7.10	41	79	8
WD008D0720.8	7.20	41	79	8
WD008D0730.8	7.30	41	79	8
WD008D0740.8	7.40	41	79	8
WD008D0750.8	7.50	41	79	8
WD008D0760.8	7.60	41	79	8
WD008D0770.8	7.70	41	79	8
WD008D0780.8	7.80	41	79	8
WD008D0790.8	7.90	41	79	8
WD008D0800.8	8.00	41	79	8
WD008D0810.10	8.10	47	89	10
WD008D0820.10	8.20	47	89	10
WD008D0830.10	8.30	47	89	10
WD008D0840.10	8.40	47	89	10
WD008D0850.10	8.50	47	89	10
WD008D0860.10	8.60	47	89	10
WD008D0870.10	8.70	47	89	10
WD008D0880.10	8.80	47	89	10
WD008D0890.10	8.90	47	89	10
WD008D0900.10	9.00	47	89	10
WD008D0910.10	9.10	47	89	10
WD008D0920.10	9.20	47	89	10
WD008D0930.10	9.30	47	89	10
WD008D0940.10	9.40	47	89	10
WD008D0950.10	9.50	47	89	10
WD008D0960.10	9.60	47	89	10
WD008D0970.10	9.70	47	89	10
WD008D0980.10	9.80	47	89	10
WD008D0990.10	9.90	47	89	10
WD008D1000.10	10.00	47	89	10
WD008D1010.12	10.10	55	102	12
WD008D1020.12	10.20	55	102	12
WD008D1030.12	10.30	55	102	12
WD008D1040.12	10.40	55	102	12
WD008D1050.12	10.50	55	102	12
WD008D1060.12	10.60	55	102	12
WD008D1070.12	10.70	55	102	12
WD008D1080.12	10.80	55	102	12
WD008D1090.12	10.90	55	102	12
WD008D1100.12	11.00	55	102	12
WD008D1110.12	11.10	55	102	12
WD008D1120.12	11.20	55	102	12
WD008D1130.12	11.30	55	102	12
WD008D1140.12	11.40	55	102	12
WD008D1150.12	11.50	55	102	12
WD008D1160.12	11.60	55	102	12
WD008D1170.12	11.70	55	102	12
WD008D1180.12	11.80	55	102	12
WD008D1190.12	11.90	55	102	12
WD008D1200.12	12.00	55	102	12
WD008D1210.14	12.10	60	107	14
WD008D1220.14	12.20	60	107	14
WD008D1230.14	12.30	60	107	14
WD008D1240.14	12.40	60	107	14
WD008D1250.14	12.50	60	107	14

Артикул	Dмм	lмм	Lмм	dмм
WD008D1260.14	12.60	60	107	14
WD008D1280.14	12.80	60	107	14
WD008D1290.14	12.90	60	107	14
WD008D1300.14	13.00	60	107	14
WD008D1320.14	13.20	60	107	14
WD008D1330.14	13.30	60	107	14
WD008D1350.14	13.50	60	107	14
WD008D1370.14	13.70	60	107	14
WD008D1380.14	13.80	60	107	14
WD008D1400.14	14.00	60	107	14
WD008D1420.16	14.20	65	115	16
WD008D1430.16	14.30	65	115	16
WD008D1440.16	14.40	65	115	16
WD008D1450.16	14.50	65	115	16
WD008D1470.16	14.70	65	115	16
WD008D1500.16	15.00	65	115	16
WD008D1520.16	15.20	65	115	16
WD008D1550.16	15.50	65	115	16
WD008D1560.16	15.60	65	115	16
WD008D1570.16	15.70	65	115	16
WD008D1580.16	15.80	65	115	16
WD008D1600.16	16.00	65	115	16
WD008D1650.18	16.50	73	123	18
WD008D1700.18	17.00	73	123	18
WD008D1750.18	17.50	73	123	18
WD008D1800.18	18.00	73	123	18
WD008D1850.20	18.50	79	131	20
WD008D1900.20	19.00	79	131	20
WD008D1950.20	19.50	79	131	20
WD008D2000.20	20.00	79	131	20

ОСНОВНЫЕ ОПЕРАЦИИ ПО ПРИМЕНЕНИЮ СВЕРЛ С ПЛОСКИМ ТОРЦОМ

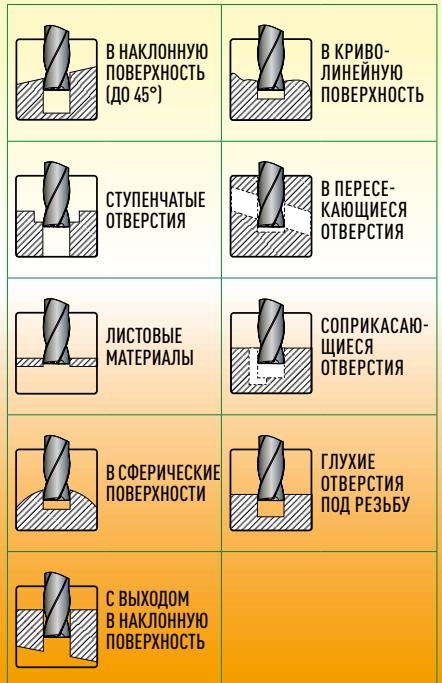

СЕРИЯ WD013

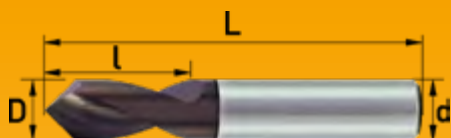

СЕРИЯ НОРМАЛЬНОЙ ДЛИНЫ

Артикул	Dмм	lмм	Lмм	dмм
WD013D0130.050	1.3	4	50	3
WD013D0170.050	1.7	5	50	3
WD013D0300.050	3.0	8	50	3
WD013D0400.050	4.0	10	50	4
WD013D0500.050	5.0	13	50	5
WD013D0600.050	6.0	15	50	6
WD013D0800.060	8.0	20	60	8
WD013D1000.075	10.0	25	75	10
WD013D1200.075	12.0	30	75	12
WD013D1600.100	16.0	35	100	16

ДЛИННАЯ СЕРИЯ

Артикул	Dмм	lмм	Lмм	dмм
WD013D0400.075	4	10	75	4
WD013D0500.075	5	13	75	5
WD013D0600.100	6	15	100	6
WD013D0800.100	8	20	100	8
WD013D1000.150	10	25	150	10
WD013D1200.150	12	30	150	12
WD013D1600.150	16	35	150	16

СЕРИЯ WD028

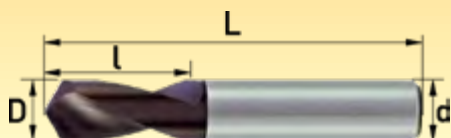

СЕРИЯ НОРМАЛЬНОЙ ДЛИНЫ

Артикул	Dмм	lмм	Lмм	dмм
WD028D0300.050	3	8	50	3
WD028D0400.050	4	10	50	4
WD028D0500.050	5	13	50	5
WD028D0600.050	6	15	50	6
WD028D0800.060	8	20	60	8
WD028D1000.075	10	25	75	10
WD028D1200.075	12	30	75	12
WD028D1600.100	16	35	100	16

ДЛИННАЯ СЕРИЯ

Артикул	Dмм	lмм	Lмм	dмм
WD028D0400.075	4	10	75	4
WD028D0500.075	5	13	75	5
WD028D0600.100	6	15	100	6
WD028D0800.100	8	20	100	8
WD028D1000.150	10	25	150	10
WD028D1200.150	12	30	150	12
WD028D1600.150	16	35	150	16

СЕРИЯ WD017

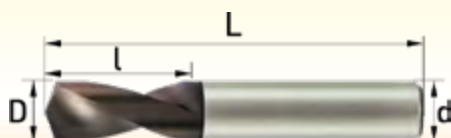

СЕРИЯ НОРМАЛЬНОЙ ДЛИНЫ

Артикул	Dмм	lмм	Lмм	dмм
WD017D0300.050	3	8	50	3
WD017D0400.050	4	10	50	4
WD017D0500.050	5	13	50	5
WD017D0600.050	6	15	50	6
WD017D0800.060	8	20	60	8
WD017D1000.075	10	25	75	10
WD017D1200.075	12	30	75	12
WD017D1600.100	16	35	100	16

ДЛИННАЯ СЕРИЯ

Артикул	Dмм	lмм	Lмм	dмм
WD017D0400.075	4	10	75	4
WD017D0500.075	5	13	75	5
WD017D0600.100	6	15	100	6
WD017D0800.100	8	20	100	8
WD017D1000.150	10	25	150	10
WD017D1200.150	12	30	150	12
WD017D1600.150	16	35	150	16



МИКРОСВЕРЛА УНИВЕРСАЛЬНЫЕ ТВЕРДОСПЛАВНЫЕ. ОБЩАЯ ОБРАБОТКА МАТЕРИАЛОВ ГРУПП Р, М, К, N, S, H

СЕРИИ KD034, KD035

MG

0~0.005

$\lambda=25^\circ$



$D \leq 1$



$D > 1$

TiAlN



Рис. 1



Рис. 2

Артикулы		D мм 0~0.005	l мм	L мм	d мм	Артикулы		D мм 0~0.005	l мм	L мм	d мм	Артикулы		D мм 0~0.005	l мм	L мм	d мм
Средняя серия Рис. 1	Длинная серия Рис. 2					Средняя серия Рис. 1	Длинная серия Рис. 2					Средняя серия Рис. 1	Длинная серия Рис. 2				
KD034D0004	—	0.040	0.40	38	3	KD034D0022	—	0.220	3.5	38	3	KD034D0046	—	0.460	6.0	38	3
—	KD035D0004		0.60			—	KD035D0022		0.220			5.0	—		KD035D0046		
KD034D00045	—	0.045	0.45			KD034D0023	—	0.230	3.5			KD034D0047	—	0.470	6.0		
—	KD035D00045		0.70			—	KD035D0023		0.230			5.0	—		KD035D0047		
KD034D0005	—	0.050	0.50			KD034D0024	—	0.240	3.5			KD034D0048	—	0.480	6.0		
—	KD035D0005		0.90			—	KD035D0024		0.240			5.0	—		KD035D0048		
KD034D00055	—	0.055	0.55			KD034D0025	—	0.250	3.5			KD034D0049	—	0.490	6.0		
—	KD035D00055		0.90			—	KD035D0025		0.250			5.0	—		KD035D0049		
KD034D00060	—	0.060	0.60			KD034D0026	—	0.260	3.5			KD034D0050	—	0.500	6.0		
—	KD035D00060		0.90			—	KD035D0026		0.260			6.0	—		KD035D0050		
KD034D00065	—	0.065	0.65			KD034D0027	—	0.270	3.5			KD034D0051	—	0.510	6.0		
—	KD035D00065		0.90			—	KD035D0027		0.270			6.0	—		KD035D0051		
KD034D0007	—	0.070	0.70			KD034D0028	—	0.280	3.5			KD034D0052	—	0.520	6.0		
—	KD035D0007		1.20			—	KD035D0028		0.280			6.0	—		KD035D0052		
KD034D00075	—	0.075	0.75			KD034D0029	—	0.290	3.5			KD034D0053	—	0.530	6.0		
—	KD035D00075		1.20			—	KD035D0029		0.290			6.0	—		KD035D0053		
KD034D0008	—	0.080	0.80			KD034D0030	—	0.300	5.0			KD034D0054	—	0.540	6.0		
—	KD035D0008		1.20			—	KD035D0030		0.300			6.0	—		KD035D0054		
KD034D00085	—	0.085	0.85			KD034D0031	—	0.310	5.0			KD034D0055	—	0.550	6.0		
—	KD035D00085		1.20			—	KD035D0031		0.310			6.0	—		KD035D0055		
KD034D0009	—	0.090	0.90	KD034D0032	—	0.320	5.0	KD034D0056	—	0.560	6.0						
—	KD035D0009		1.20	—	KD035D0032		0.320	6.0	—		KD035D0056	0.560	9.0				
KD034D00095	—	0.095	0.95	KD034D0033	—	0.330	5.0	KD034D0057	—	0.570	6.0						
—	KD035D00095		1.20	—	KD035D0033		0.330	6.0	—		KD035D0057	0.570	9.0				
KD034D0010	—	0.100	1.50	KD034D0034	—	0.340	5.0	KD034D0058	—	0.580	6.0						
—	KD035D0010		2.00	—	KD035D0034		0.340	6.0	—		KD035D0058	0.580	9.0				
KD034D0011	—	0.110	1.50	KD034D0035	—	0.350	5.0	KD034D0059	—	0.590	6.0						
—	KD035D0011		2.00	—	KD035D0035		0.350	6.0	—		KD035D0059	0.590	9.0				
KD034D0012	—	0.120	2.50	KD034D0036	—	0.360	5.0	KD034D0060	—	0.600	7.0						
—	KD035D0012		2.00	—	KD035D0036		0.360	6.0	—		KD035D0060	0.600	9.0				
KD034D0013	—	0.130	2.50	KD034D0037	—	0.370	5.0	KD034D0061	—	0.610	7.0						
—	KD035D0013		3.00	—	KD035D0037		0.370	6.0	—		KD035D0061	0.610	9.0				
KD034D0014	—	0.140	2.50	KD034D0038	—	0.380	5.0	KD034D0062	—	0.620	7.0						
—	KD035D0014		3.00	—	KD035D0038		0.380	6.0	—		KD035D0062	0.620	9.0				
KD034D0015	—	0.150	2.50	KD034D0039	—	0.390	5.0	KD034D0063	—	0.630	7.0						
—	KD035D0015		3.00	—	KD035D0039		0.390	6.0	—		KD035D0063	0.630	9.0				
KD034D0016	—	0.160	2.50	KD034D0040	—	0.400	6.0	KD034D0064	—	0.640	7.0						
—	KD035D0016		4.00	—	KD035D0040		0.400	6.0	—		KD035D0064	0.640	9.0				
KD034D0017	—	0.170	2.50	KD034D0041	—	0.410	6.0	KD034D0065	—	0.650	7.0						
—	KD035D0017		4.00	—	KD035D0041		0.410	7.0	—		KD035D0065	0.650	9.0				
KD034D0018	—	0.180	2.50	KD034D0042	—	0.420	6.0	KD034D0066	—	0.660	7.0						
—	KD035D0018		4.00	—	KD035D0042		0.420	7.0	—		KD035D0066	0.660	9.0				
KD034D0019	—	0.190	2.50	KD034D0043	—	0.430	6.0	KD034D0067	—	0.670	7.0						
—	KD035D0019		4.00	—	KD035D0043		0.430	7.0	—		KD035D0067	0.670	9.0				
KD034D0020	—	0.200	3.50	KD034D0044	—	0.440	6.0	KD034D0068	—	0.680	7.0						
—	KD035D0020		4.00	—	KD035D0044		0.440	7.0	—		KD035D0068	0.680	9.0				
KD034D0021	—	0.210	3.50	KD034D0045	—	0.450	6.0	KD034D0069	—	0.690	7.0						
—	KD035D0021		5.00	—	KD035D0045		0.450	7.0	—		KD035D0069	0.690	9.0				

Свёрла с размерами, отсутствующими в таблице, изготавливаются по запросу потребителя

СЕРИИ KD034, KD035

MG 0~0.005 $\lambda=25^\circ$ 118° 135° **TiAlN**

P **M** **K** **N** **S** **H**

Продолжение таблицы



Рис. 1



Рис. 2

Артикулы		D мм 0~0.005	l мм	L мм	d мм	Артикулы				D мм 0~0.005	l мм	L мм	d мм	Артикулы			
Средняя серия Рис. 1	Длинная серия Рис. 2					Средняя серия Рис. 1	Длинная серия Рис. 2	Средняя серия Рис. 1	Длинная серия Рис. 2					Средняя серия Рис. 1	Длинная серия Рис. 2		
KD034D0070	—	0.700	8.0	38	3	KD034D00895	—	0.895	8.0	38	3	KD034D10088	—	1.088	10.0	38	
—	KD035D0070		9.0			—	KD035D00895		10.0			—	KD035D10088		12.0	50	
KD034D0071	—	0.710	8.0	38	3	KD034D00897	—	0.897	8.0	38	3	KD034D0109	—	1.090	10.0	38	
—	KD035D0071		10.0			—	KD035D00897		10.0			—	KD035D0109		12.0	50	
KD034D0072	—	0.720	8.0	38	3	KD034D0090	—	0.900	8.0	38	3	KD034D01093	—	1.093	10.0	38	
—	KD035D0072		10.0			—	KD035D0090		10.0			—	KD035D01093		12.0	50	
KD034D0073	—	0.730	8.0	38	3	KD034D0091	—	0.910	8.0	38	3	KD034D01095	—	1.095	10.0	38	
—	KD035D0073		10.0			—	KD035D0091		10.0			—	KD035D01095		12.0	50	
KD034D0074	—	0.740	8.0	38	3	KD034D0092	—	0.920	8.0	38	3	KD034D01097	—	1.097	10.0	38	
—	KD035D0074		10.0			—	KD035D0092		10.0			—	KD035D01097		12.0	50	
KD034D0075	—	0.750	8.0	38	3	KD034D0093	—	0.930	8.0	38	3	KD034D0110	—	1.100	10.0	38	
—	KD035D0075		10.0			—	KD035D0093		10.0			—	KD035D0110		12.0	50	
KD034D0076	—	0.760	8.0	38	3	KD034D0094	—	0.940	8.0	38	3	KD034D0111	—	1.110	10.0	38	
—	KD035D0076		10.0			—	KD035D0094		10.0			—	KD035D0111		12.0	50	
KD034D0077	—	0.770	8.0	38	3	KD034D0095	—	0.950	8.0	38	3	KD034D0112	—	1.120	10.0	38	
—	KD035D0077		10.0			—	KD035D0095		10.0			—	KD035D0112		12.0	50	
KD034D0078	—	0.780	8.0	38	3	KD034D0096	—	0.960	8.0	38	3	KD034D0113	—	1.130	10.0	38	
—	KD035D0078		10.0			—	KD035D0096		10.0			—	KD035D0113		12.0	50	
KD034D0079	—	0.790	8.0	38	3	KD034D0097	—	0.970	8.0	38	3	KD034D0114	—	1.140	10.0	38	
—	KD035D0079		10.0			—	KD035D0097		10.0			—	KD035D0114		12.0	50	
KD034D0080	—	0.800	8.0	38	3	KD034D0098	—	0.980	8.0	38	3	KD034D0115	—	1.150	10.0	38	
—	KD035D0080		10.0			—	KD035D0098		10.0			—	KD035D0115		12.0	50	
KD034D0081	—	0.810	8.0	38	3	KD034D0099	—	0.990	8.0	38	3	KD034D0116	—	1.160	10.0	38	
—	KD035D0081		10.0			—	KD035D0099		10.0			—	KD035D0116		12.0	50	
KD034D0082	—	0.820	8.0	38	3	KD034D0100	—	1.000	10.0	38	3	KD034D0117	—	1.170	10.0	38	
—	KD035D0082		10.0			—	KD035D0100		12.0			50	—		KD035D0117	12.0	50
KD034D0083	—	0.830	8.0	38	3	KD034D0101	—	1.010	10.0	38	3	KD034D0118	—	1.180	10.0	38	
—	KD035D0083		10.0			—	KD035D0101		12.0			50	—		KD035D0118	12.0	50
KD034D0084	—	0.840	8.0	38	3	KD034D0102	—	1.020	10.0	38	3	KD034D0119	—	1.190	10.0	38	
—	KD035D0084		10.0			—	KD035D0102		12.0			50	—		KD035D0119	12.0	50
KD034D0085	—	0.850	8.0	38	3	KD034D0103	—	1.030	10.0	38	3	KD034D0120	—	1.200	10.0	38	
—	KD035D0085		10.0			—	KD035D0103		12.0			50	—		KD035D0120	15.0	50
KD034D0086	—	0.860	8.0	38	3	KD034D0104	—	1.040	10.0	38	3	KD034D0121	—	1.210	10.0	38	
—	KD035D0086		10.0			—	KD035D0104		12.0			50	—		KD035D0121	15.0	50
KD034D0087	—	0.870	8.0	38	3	KD034D0105	—	1.050	10.0	38	3	KD034D0122	—	1.220	10.0	38	
—	KD035D0087		10.0			—	KD035D0105		12.0			50	—		KD035D0122	15.0	50
KD034D0088	—	0.880	8.0	38	3	KD034D0106	—	1.060	10.0	38	3	KD034D0123	—	1.230	10.0	38	
—	KD035D0088		10.0			—	KD035D0106		12.0			50	—		KD035D0123	15.0	50
KD034D00883	—	0.883	8.0	38	3	KD034D0107	—	1.070	10.0	38	3	KD034D0124	—	1.240	10.0	38	
—	KD035D00883		10.0			—	KD035D0107		12.0			50	—		KD035D0124	15.0	50
KD034D00885	—	0.885	8.0	38	3	KD034D0108	—	1.080	10.0	38	3	KD034D0125	—	1.250	10.0	38	
—	KD035D00885		10.0			—	KD035D0108		12.0			50	—		KD035D0125	15.0	50
KD034D00887	—	0.887	8.0	38	3	KD034D01083	—	1.083	10.0	38	3	KD034D01255	—	1.255	10.0	38	
—	KD035D00887		10.0			—	KD035D01083		12.0			50	—		KD035D01255	15.0	50
KD034D00888	—	0.888	8.0	38	3	KD034D01085	—	1.085	10.0	38	3	KD034D0126	—	1.260	10.0	38	
—	KD035D00888		10.0			—	KD035D01085		12.0			50	—		KD035D0126	15.0	50
KD034D0089	—	0.890	8.0	38	3	KD034D01087	—	1.087	10.0	38	3	KD034D01265	—	1.265	10.0	38	
—	KD035D0089		10.0			—	KD035D01087		12.0			50	—		KD035D01265	15.0	50



МИКРОСВЕРЛА УНИВЕРСАЛЬНЫЕ ТВЕРДОСПЛАВНЫЕ. ОБЩАЯ ОБРАБОТКА МАТЕРИАЛОВ ГРУПП Р, М, К, N, S, H

СЕРИИ KD034, KD035

MG

0-0.005

$\lambda=25^\circ$



TiAlN



$D \leq 1$

$D > 1$

Продолжение таблицы



Рис. 1



Рис. 2

Артикулы				D мм 0-0.005	L мм	L мм	d мм	Артикулы				D мм 0-0.005	L мм	L мм	d мм
Средняя серия Рис. 1	Длинная серия Рис. 2	Средняя серия Рис. 1	Длинная серия Рис. 2					Средняя серия Рис. 1	Длинная серия Рис. 2						
KD034D0127	—	—	—	1.270	10.0	38	3	KD034D0148	—	—	—	1.480	10.0	38	3
—	KD035D0127	—	—	15.0	50	—	—	—	KD035D0148	—	—	1.480	15.0	50	—
KD034D0128	—	—	—	1.280	10.0	38	3	KD034D0149	—	—	—	1.490	10.0	38	3
—	KD035D0128	—	—	15.0	50	—	—	—	KD035D0149	—	—	1.490	15.0	50	—
KD034D01283	—	—	—	1.283	10.0	38	3	KD034D0150	—	—	—	1.500	10.0	38	3
—	KD035D01283	—	—	15.0	50	—	—	—	KD035D0150	—	—	1.500	20.0	50	—
KD034D01285	—	—	—	1.285	10.0	38	3	KD034D0151	—	—	—	1.510	10.0	38	3
—	KD035D01285	—	—	15.0	50	—	—	—	KD035D0151	—	—	1.510	20.0	50	—
KD034D0129	—	—	—	1.290	10.0	38	3	KD034D0152	—	—	—	1.520	10.0	38	3
—	KD035D0129	—	—	15.0	50	—	—	—	KD035D0152	—	—	1.520	20.0	50	—
KD034D0130	—	—	—	1.300	10.0	38	3	KD034D0153	—	—	—	1.530	10.0	38	3
—	KD035D0130	—	—	15.0	50	—	—	—	KD035D0153	—	—	1.530	20.0	50	—
KD034D0131	—	—	—	1.310	10.0	38	3	KD034D0154	—	—	—	1.540	10.0	38	3
—	KD035D0131	—	—	15.0	50	—	—	—	KD035D0154	—	—	1.540	20.0	50	—
KD034D0132	—	—	—	1.320	10.0	38	3	KD034D0155	—	—	—	1.550	10.0	38	3
—	KD035D0132	—	—	15.0	50	—	—	—	KD035D0155	—	—	1.550	20.0	50	—
KD034D0133	—	—	—	1.330	10.0	38	3	KD034D0156	—	—	—	1.560	10.0	38	3
—	KD035D0133	—	—	15.0	50	—	—	—	KD035D0156	—	—	1.560	20.0	50	—
KD034D0134	—	—	—	1.340	10.0	38	3	KD034D0157	—	—	—	1.570	10.0	38	3
—	KD035D0134	—	—	15.0	50	—	—	—	KD035D0157	—	—	1.570	20.0	50	—
KD034D0135	—	—	—	1.350	10.0	38	3	KD034D0158	—	—	—	1.580	10.0	38	3
—	KD035D0135	—	—	15.0	50	—	—	—	KD035D0158	—	—	1.580	20.0	50	—
KD034D0136	—	—	—	1.360	10.0	38	3	KD034D0159	—	—	—	1.590	10.0	38	3
—	KD035D0136	—	—	15.0	50	—	—	—	KD035D0159	—	—	1.590	20.0	50	—
KD034D0137	—	—	—	1.370	10.0	38	3	KD034D0160	—	—	—	1.600	12.0	38	3
—	KD035D0137	—	—	15.0	50	—	—	—	KD035D0160	—	—	1.600	20.0	50	—
KD034D0138	—	—	—	1.380	10.0	38	3	KD034D0161	—	—	—	1.610	12.0	38	3
—	KD035D0138	—	—	15.0	50	—	—	—	KD035D0161	—	—	1.610	20.0	50	—
KD034D0139	—	—	—	1.390	10.0	38	3	KD034D0162	—	—	—	1.620	12.0	38	3
—	KD035D0139	—	—	15.0	50	—	—	—	KD035D0162	—	—	1.620	20.0	50	—
KD034D0140	—	—	—	1.400	10.0	38	3	KD034D0163	—	—	—	1.630	12.0	38	3
—	KD035D0140	—	—	15.0	50	—	—	—	KD035D0163	—	—	1.630	20.0	50	—
KD034D0141	—	—	—	1.410	10.0	38	3	KD034D0164	—	—	—	1.640	12.0	38	3
—	KD035D0141	—	—	15.0	50	—	—	—	KD035D0164	—	—	1.640	20.0	50	—
KD034D0142	—	—	—	1.420	10.0	38	3	KD034D0165	—	—	—	1.650	12.0	38	3
—	KD035D0142	—	—	15.0	50	—	—	—	KD035D0165	—	—	1.650	20.0	50	—
KD034D0143	—	—	—	1.430	10.0	38	3	KD034D0166	—	—	—	1.660	12.0	38	3
—	KD035D0143	—	—	15.0	50	—	—	—	KD035D0166	—	—	1.660	20.0	50	—
KD034D0144	—	—	—	1.440	10.0	38	3	KD034D0167	—	—	—	1.670	12.0	38	3
—	KD035D0144	—	—	15.0	50	—	—	—	KD035D0167	—	—	1.670	20.0	50	—
KD034D0145	—	—	—	1.450	10.0	38	3	KD034D0168	—	—	—	1.680	12.0	38	3
—	KD035D0145	—	—	15.0	50	—	—	—	KD035D0168	—	—	1.680	20.0	50	—
KD034D01455	—	—	—	1.455	10.0	38	3	KD034D0169	—	—	—	1.690	12.0	38	3
—	KD035D01455	—	—	15.0	50	—	—	—	KD035D0169	—	—	1.690	20.0	50	—
KD034D0146	—	—	—	1.460	10.0	38	3	KD034D0170	—	—	—	1.700	12.0	38	3
—	KD035D0146	—	—	15.0	50	—	—	—	KD035D0170	—	—	1.700	20.0	50	—
KD034D0147	—	—	—	1.470	10.0	38	3	KD034D0171	—	—	—	1.710	12.0	38	3
—	KD035D0147	—	—	15.0	50	—	—	—	KD035D0171	—	—	1.710	20.0	50	—
KD034D0172	—	—	—	1.720	12.0	38	3	KD034D0172	—	—	—	1.720	12.0	38	3
—	KD035D0172	—	—	20.0	50	—	—	—	KD035D0172	—	—	1.720	20.0	50	—
KD034D0173	—	—	—	1.730	12.0	38	3	KD034D0173	—	—	—	1.730	12.0	38	3
—	KD035D0173	—	—	20.0	50	—	—	—	KD035D0173	—	—	1.730	20.0	50	—
KD034D0174	—	—	—	1.740	12.0	38	3	KD034D0174	—	—	—	1.740	12.0	38	3
—	KD035D0174	—	—	20.0	50	—	—	—	KD035D0174	—	—	1.740	20.0	50	—
KD034D0175	—	—	—	1.750	12.0	38	3	KD034D0175	—	—	—	1.750	12.0	38	3
—	KD035D0175	—	—	20.0	50	—	—	—	KD035D0175	—	—	1.750	20.0	50	—
KD034D0176	—	—	—	1.760	12.0	38	3	KD034D0176	—	—	—	1.760	12.0	38	3
—	KD035D0176	—	—	20.0	50	—	—	—	KD035D0176	—	—	1.760	20.0	50	—
KD034D0177	—	—	—	1.770	12.0	38	3	KD034D0177	—	—	—	1.770	12.0	38	3
—	KD035D0177	—	—	20.0	50	—	—	—	KD035D0177	—	—	1.770	20.0	50	—
KD034D0178	—	—	—	1.780	12.0	38	3	KD034D0178	—	—	—	1.780	12.0	38	3
—	KD035D0178	—	—	20.0	50	—	—	—	KD035D0178	—	—	1.780	20.0	50	—
KD034D0179	—	—	—	1.790	12.0	38	3	KD034D0179	—	—	—	1.790	12.0	38	3
—	KD035D0179	—	—	20.0	50	—	—	—	KD035D0179	—	—	1.790	20.0	50	—
KD034D0180	—	—	—	1.800	12.0	38	3	KD034D0180	—	—	—	1.800	12.0	38	3
—	KD035D0180	—	—	20.0	50	—	—	—	KD035D0180	—	—	1.800	20.0	50	—
KD034D0181	—	—	—	1.810	12.0	38	3	KD034D0181	—	—	—	1.810	12.0	38	3
—	KD035D0181	—	—	20.0	50	—	—	—	KD035D0181	—	—	1.810	20.0	50	—
KD034D0182	—	—	—	1.820	12.0	38	3	KD034D0182	—	—	—	1.820	12.0	38	3
—	KD035D0182	—	—	20.0	50	—	—	—	KD035D0182	—	—	1.820	20.0	50	—
KD034D0183	—	—	—	1.830	12.0	38	3	KD034D0183	—	—	—	1.830	12.0	38	3
—	KD035D0183	—	—	20.0	50	—	—	—	KD035D0183	—	—	1.830	20.0	50	—
KD034D0184	—	—	—	1.840	12.0	38	3	KD034D0184	—	—	—	1.840	12.0	38	3
—	KD035D0184	—	—	20.0	50	—	—	—	KD035D0184	—	—	1.840	20.0	50	—
KD034D0185	—	—	—	1.850	12.0	38	3	KD034D0185	—	—	—	1.850	12.0	38	3
—	KD035D0185	—	—	20.0	50	—	—	—	KD035D0185	—	—	1.850	20.0	50	—
KD034D0186	—	—	—	1.860	12.0	38	3	KD034D0186	—	—	—	1.860	12.0	38	3
—	KD035D0186	—	—	20.0	50	—	—	—	KD035D0186	—	—	1.860	20.0	50	—
KD034D0187	—	—	—	1.870	12.0	38	3	KD034D0187	—	—	—	1.870	12.0	38	3
—	KD035D0187	—	—	20.0	50	—	—	—	KD035D0187	—	—	1.870	20.0	50	—
KD034D0188	—	—	—	1.880	12.0	38	3	KD034D0188	—	—	—	1.880	12.0	38	3
—	KD035D0188	—	—	20.0	50	—	—	—	KD035D0188	—	—	1.880	20.0	50	—
KD034D0189	—	—	—	1.890	12.0	38	3	KD034D0189	—	—	—	1.890	12.0	38	3
—	KD035D0189	—	—	20.0	50	—	—	—	KD035D0189	—	—	1.890	20.0	50	—
KD034D0190	—	—	—	1.900	12.0	38	3	KD034D0190	—	—	—	1.900	12.0	38	3
—	KD035D0190	—	—	20											

СЕРИИ KD034, KD035

MG 0-0.005 $\lambda=25^\circ$ 118° 135° **TiAlN**

P **M** **K** **N** **S** **H**

Продолжение таблицы



Рис. 1



Рис. 2

Артикулы				D мм 0-0.005	L мм	L мм	d мм	Артикулы				D мм 0-0.005	L мм	L мм	d мм	Артикулы			
Средняя серия Рис. 1	Длинная серия Рис. 2	Средняя серия Рис. 1	Длинная серия Рис. 2					Средняя серия Рис. 1	Длинная серия Рис. 2	Средняя серия Рис. 1	Длинная серия Рис. 2								
KD034D0196	—	—	—	1.960	12.0	38	2.200	12.0	38	KD034D0245	—	2.450	12.0	38	3	3	3	3	
—	KD035D0196	—	—		20.0	50		—	—	—	—		—	KD035D0245					—
KD034D0197	—	—	—	1.970	12.0	38	2.210	12.0	38	KD034D0246	—	2.460	12.0	38	3	3	3	3	
—	KD035D0197	—	—		20.0	50		—	—	—	—		—	KD035D0246					—
KD034D0198	—	—	—	1.980	12.0	38	2.220	12.0	38	KD034D0247	—	2.470	12.0	38	3	3	3	3	
—	KD035D0198	—	—		20.0	50		—	—	—	—		—	KD035D0247					—
KD034D0199	—	—	—	1.990	12.0	38	2.230	12.0	38	KD034D0248	—	2.480	12.0	38	3	3	3	3	
—	KD035D0199	—	—		20.0	50		—	—	—	—		—	KD035D0248					—
KD034D0200	—	—	—	2.000	12.0	38	2.240	12.0	38	KD034D0249	—	2.490	12.0	38	3	3	3	3	
—	KD035D0200	—	—		20.0	50		—	—	—	—		—	KD035D0249					—
KD034D0201	—	—	—	2.010	12.0	38	2.250	12.0	38	KD034D0250	—	2.500	12.0	38	3	3	3	3	
—	KD035D0201	—	—		25.0	60		—	—	—	—		—	KD035D0250					—
KD034D0202	—	—	—	2.020	12.0	38	2.260	12.0	38	KD034D0251	—	2.510	12.0	38	3	3	3	3	
—	KD035D0202	—	—		25.0	60		—	—	—	—		—	KD035D0251					—
KD034D0203	—	—	—	2.030	12.0	38	2.270	12.0	38	KD034D0252	—	2.520	12.0	38	3	3	3	3	
—	KD035D0203	—	—		25.0	60		—	—	—	—		—	KD035D0252					—
KD034D0204	—	—	—	2.040	12.0	38	2.280	12.0	38	KD034D0253	—	2.530	12.0	38	3	3	3	3	
—	KD035D0204	—	—		25.0	60		—	—	—	—		—	KD035D0253					—
KD034D0205	—	—	—	2.050	12.0	38	2.290	12.0	38	KD034D0254	—	2.540	12.0	38	3	3	3	3	
—	KD035D0205	—	—		25.0	60		—	—	—	—		—	KD035D0254					—
KD034D0206	—	—	—	2.060	12.0	38	2.300	12.0	38	KD034D0255	—	2.550	12.0	38	3	3	3	3	
—	KD035D0206	—	—		25.0	60		—	—	—	—		—	KD035D0255					—
KD034D0207	—	—	—	2.070	12.0	38	2.310	12.0	38	KD034D0256	—	2.560	12.0	38	3	3	3	3	
—	KD035D0207	—	—		25.0	60		—	—	—	—		—	KD035D0256					—
KD034D0208	—	—	—	2.080	12.0	38	2.330	12.0	38	KD034D0257	—	2.570	12.0	38	3	3	3	3	
—	KD035D0208	—	—		25.0	60		—	—	—	—		—	KD035D0257					—
KD034D0209	—	—	—	2.090	12.0	38	2.340	12.0	38	KD034D0258	—	2.580	12.0	38	3	3	3	3	
—	KD035D0209	—	—		25.0	60		—	—	—	—		—	KD035D0258					—
KD034D0210	—	—	—	2.100	12.0	38	2.350	12.0	38	KD034D0259	—	2.590	12.0	38	3	3	3	3	
—	KD035D0210	—	—		25.0	60		—	—	—	—		—	KD035D0259					—
KD034D0211	—	—	—	2.110	12.0	38	2.360	12.0	38	KD034D0260	—	2.600	12.0	38	3	3	3	3	
—	KD035D0211	—	—		25.0	60		—	—	—	—		—	KD035D0260					—
KD034D0212	—	—	—	2.120	12.0	38	2.370	12.0	38	KD034D0261	—	2.610	12.0	38	3	3	3	3	
—	KD035D0212	—	—		25.0	60		—	—	—	—		—	KD035D0261					—
KD034D0213	—	—	—	2.130	12.0	38	2.380	12.0	38	KD034D0262	—	2.620	12.0	38	3	3	3	3	
—	KD035D0213	—	—		25.0	60		—	—	—	—		—	KD035D0262					—
KD034D0214	—	—	—	2.140	12.0	38	2.390	12.0	38	KD034D0263	—	2.630	12.0	38	3	3	3	3	
—	KD035D0214	—	—		25.0	60		—	—	—	—		—	KD035D0263					—
KD034D0215	—	—	—	2.150	12.0	38	2.400	12.0	38	KD034D0264	—	2.640	12.0	38	3	3	3	3	
—	KD035D0215	—	—		25.0	60		—	—	—	—		—	KD035D0264					—
KD034D0216	—	—	—	2.160	12.0	38	2.410	12.0	38	KD034D0265	—	2.650	12.0	38	3	3	3	3	
—	KD035D0216	—	—		25.0	60		—	—	—	—		—	KD035D0265					—
KD034D0217	—	—	—	2.170	12.0	38	2.420	12.0	38	KD034D0266	—	2.660	12.0	38	3	3	3	3	
—	KD035D0217	—	—		25.0	60		—	—	—	—		—	KD035D0266					—
KD034D0218	—	—	—	2.180	12.0	38	2.430	12.0	38	KD034D0267	—	2.670	12.0	38	3	3	3	3	
—	KD035D0218	—	—		25.0	60		—	—	—	—		—	KD035D0267					—
KD034D0219	—	—	—	2.190	12.0	38	2.440	12.0	38	KD034D0268	—	2.680	12.0	38	3	3	3	3	
—	KD035D0219	—	—		25.0	60		—	—	—	—		—	KD035D0268					—



МИКРОСВЕРЛА УНИВЕРСАЛЬНЫЕ ТВЕРДОСПЛАВНЫЕ. ОБЩАЯ ОБРАБОТКА МАТЕРИАЛОВ ГРУПП Р, М, К, N, S, H

СЕРИИ KD034, KD035

MG

0-0.005

$\lambda=25^\circ$

118°

135°

TiAlN



Окончание таблицы



Рис. 1



Рис. 2

Артикулы				Артикулы				Артикулы									
Средняя серия Рис. 1	Длинная серия Рис. 2	D мм 0-0.005	L мм	L мм	d мм	Средняя серия Рис. 1	Длинная серия Рис. 2	D мм 0-0.005	L мм	L мм	d мм	Средняя серия Рис. 1	Длинная серия Рис. 2	D мм 0-0.005	L мм	L мм	d мм
KD034D0269	—	2.690	12.0	38	3	KD034D0279	—	2.790	12.0	38	3	KD034D0290	—	2.900	12.0	38	3
—	KD035D0269		25.0	60		—	KD035D0279		25.0	60		—	KD035D0290		25.0	60	
KD034D0270	—	2.700	12.0	38	3	KD034D0280	—	2.800	12.0	38	3	KD034D0291	—	2.910	12.0	38	3
—	KD035D0270		25.0	60		—	KD035D0280		25.0	60		—	KD035D0291		25.0	60	
KD034D0271	—	2.710	12.0	38	3	KD034D0281	—	2.810	12.0	38	3	KD034D0292	—	2.920	12.0	38	3
—	KD035D0271		25.0	60		—	KD035D0281		25.0	60		—	KD035D0292		25.0	60	
KD034D0272	—	2.720	12.0	38	3	KD034D0282	—	2.820	12.0	38	3	KD034D0293	—	2.930	12.0	38	3
—	KD035D0272		25.0	60		—	KD035D0282		25.0	60		—	KD035D0293		25.0	60	
KD034D0273	—	2.730	12.0	38	3	KD034D0283	—	2.830	12.0	38	3	KD034D0294	—	2.940	12.0	38	3
—	KD035D0273		25.0	60		—	KD035D0283		25.0	60		—	KD035D0294		25.0	60	
KD034D0274	—	2.740	12.0	38	3	KD034D0284	—	2.840	12.0	38	3	KD034D0295	—	2.950	12.0	38	3
—	KD035D0274		25.0	60		—	KD035D0284		25.0	60		—	KD035D0295		25.0	60	
KD034D0275	—	2.750	12.0	38	3	KD034D0285	—	2.850	12.0	38	3	KD034D0296	—	2.960	12.0	38	3
—	KD035D0275		25.0	60		—	KD035D0285		25.0	60		—	KD035D0296		25.0	60	
KD034D0276	—	2.760	12.0	38	3	KD034D0286	—	2.860	12.0	38	3	KD034D0297	—	2.970	12.0	38	3
—	KD035D0276		25.0	60		—	KD035D0286		25.0	60		—	KD035D0297		25.0	60	
KD034D0277	—	2.770	12.0	38	3	KD034D0287	—	2.870	12.0	38	3	KD034D0298	—	2.980	12.0	38	3
—	KD035D0277		25.0	60		—	KD035D0287		25.0	60		—	KD035D0298		25.0	60	
KD034D0278	—	2.780	12.0	38	3	KD034D0288	—	2.880	12.0	38	3	KD034D0299	—	2.990	12.0	38	3
—	KD035D0278		25.0	60		—	KD035D0288		25.0	60		—	KD035D0299		25.0	60	
KD034D02785	—	2.785	12.0	38	3	KD034D0289	—	2.890	12.0	38	3	KD034D0300	—	3.000	12.0	38	3
—	KD035D02785		25.0	60		—	KD035D0289		25.0	60		—	KD035D0300		25.0	60	

micro



2D0166

Сверло 1,66

micro



МИКРОСВЕРЛА ТВЕРДОСПЛАВНЫЕ. ДЛЯ ОБРАБОТКИ МЯГКИХ МАТЕРИАЛОВ, СПЛАВОВ ЦВЕТНЫХ МЕТАЛЛОВ, ПЛАСТИКОВ, ЛЕГКООБРАБАТЫВАЕМЫХ СТАЛЕЙ

СЕРИИ KD031, KD032

MG

0-0.003

$\lambda=35^\circ$



Рис. 1



Рис. 2

Артикулы		D мм 0-0.003	l мм	L мм	d мм	Артикулы		D мм 0-0.003	l мм	L мм	d мм	Артикулы		D мм 0-0.003	l мм	L мм	d мм
Средняя серия Рис. 1	Длинная серия Рис. 2					Средняя серия Рис. 1	Длинная серия Рис. 2					Средняя серия Рис. 1	Длинная серия Рис. 2				
KD031D0004	—	0.040	0.40	38	3	KD031D0022	—	0.220	3.5	38	3	KD031D0046	—	0.460	6.0	38	3
—	KD032D0004		0.60			—	KD032D0022		—			5.0	—		KD032D0046		
KD031D00045	—	0.045	0.45			KD031D0023	—	0.230	3.5			KD031D0047	—	0.470	6.0		
—	KD032D00045		0.70			—	KD032D0023		—			5.0	—		KD032D0047		
KD031D0005	—	0.050	0.50			KD031D0024	—	0.240	3.5			KD031D0048	—	0.480	6.0		
—	KD032D0005		0.90			—	KD032D0024		—			5.0	—		KD032D0048		
KD031D00055	—	0.055	0.55			KD031D0025	—	0.250	3.5			KD031D0049	—	0.490	6.0		
—	KD032D00055		0.90			—	KD032D0025		—			5.0	—		KD032D0049		
KD031D00060	—	0.060	0.60			KD031D0026	—	0.260	3.5			KD031D0050	—	0.500	6.0		
—	KD032D00060		0.90			—	KD032D0026		—			6.0	—		KD032D0050		
KD031D00065	—	0.065	0.65			KD031D0027	—	0.270	3.5			KD031D0051	—	0.510	6.0		
—	KD032D00065		0.90			—	KD032D0027		—			6.0	—		KD032D0051		
KD031D0007	—	0.070	0.70			KD031D0028	—	0.280	3.5			KD031D0052	—	0.520	6.0		
—	KD032D0007		1.20			—	KD032D0028		—			6.0	—		KD032D0052		
KD031D00075	—	0.075	0.75			KD031D0029	—	0.290	3.5			KD031D0053	—	0.530	6.0		
—	KD032D00075		1.20			—	KD032D0029		—			6.0	—		KD032D0053		
KD031D0008	—	0.080	0.80			KD031D0030	—	0.300	5.0			KD031D0054	—	0.540	6.0		
—	KD032D0008		1.20			—	KD032D0030		—			6.0	—		KD032D0054		
KD031D00085	—	0.085	0.85			KD031D0031	—	0.310	5.0			KD031D0055	—	0.550	6.0		
—	KD032D00085		1.20			—	KD032D0031		—			6.0	—		KD032D0055		
KD031D0009	—	0.090	0.90			KD031D0032	—	0.320	5.0			KD031D0056	—	0.560	6.0		
—	KD032D0009		1.20			—	KD032D0032		—			6.0	—		KD032D0056		
KD031D00095	—	0.095	0.95			KD031D0033	—	0.330	5.0			KD031D0057	—	0.570	6.0		
—	KD032D00095		1.20			—	KD032D0033		—			6.0	—		KD032D0057		
KD031D0010	—	0.100	1.50			KD031D0034	—	0.340	5.0			KD031D0058	—	0.580	6.0		
—	KD032D0010		2.00			—	KD032D0034		—			6.0	—		KD032D0058		
KD031D0011	—	0.110	1.50			KD031D0035	—	0.350	5.0			KD031D0059	—	0.590	6.0		
—	KD032D0011		2.00			—	KD032D0035		—			6.0	—		KD032D0059		
KD031D0012	—	0.120	2.50	KD031D0036	—	0.360	5.0	KD031D0060	—	0.600	7.0						
—	KD032D0012		2.00	—	KD032D0036		—	6.0	—		KD032D0060	—	9.0				
KD031D0013	—	0.130	2.50	KD031D0037	—	0.370	5.0	KD031D0061	—	0.610	7.0						
—	KD032D0013		3.00	—	KD032D0037		—	6.0	—		KD032D0061	—	9.0				
KD031D0014	—	0.140	2.50	KD031D0038	—	0.380	5.0	KD031D0062	—	0.620	7.0						
—	KD032D0014		3.00	—	KD032D0038		—	6.0	—		KD032D0062	—	9.0				
KD031D0015	—	0.150	2.50	KD031D0039	—	0.390	5.0	KD031D0063	—	0.630	7.0						
—	KD032D0015		3.00	—	KD032D0039		—	6.0	—		KD032D0063	—	9.0				
KD031D0016	—	0.160	2.50	KD031D0040	—	0.400	6.0	KD031D0064	—	0.640	7.0						
—	KD032D0016		4.00	—	KD032D0040		—	6.0	—		KD032D0064	—	9.0				
KD031D0017	—	0.170	2.50	KD031D0041	—	0.410	6.0	KD031D0065	—	0.650	7.0						
—	KD032D0017		4.00	—	KD032D0041		—	7.0	—		KD032D0065	—	9.0				
KD031D0018	—	0.180	2.50	KD031D0042	—	0.420	6.0	KD031D0066	—	0.660	7.0						
—	KD032D0018		4.00	—	KD032D0042		—	7.0	—		KD032D0066	—	9.0				
KD031D0019	—	0.190	2.50	KD031D0043	—	0.430	6.0	KD031D0067	—	0.670	7.0						
—	KD032D0019		4.00	—	KD032D0043		—	7.0	—		KD032D0067	—	9.0				
KD031D0020	—	0.200	3.50	KD031D0044	—	0.440	6.0	KD031D0068	—	0.680	7.0						
—	KD032D0020		4.00	—	KD032D0044		—	7.0	—		KD032D0068	—	9.0				
KD031D0021	—	0.210	3.50	KD031D0045	—	0.450	6.0	KD031D0069	—	0.690	7.0						
—	KD032D0021		5.00	—	KD032D0045		—	7.0	—		KD032D0069	—	9.0				

Свёрла с размерами, отсутствующими в таблице, изготавливаются по запросу потребителя

СЕРИИ KD031, KD032

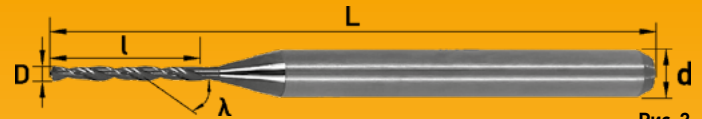
MG

0-0.003

$\lambda=35^\circ$



Продолжение таблицы



Рис. 1



Рис. 2

Артикулы		D мм 0-0.003	L мм	L мм	d мм	Артикулы		D мм 0-0.003	L мм	L мм	d мм	Артикулы		D мм 0-0.003	L мм	L мм	d мм
Средняя серия Рис. 1	Длинная серия Рис. 2					Средняя серия Рис. 1	Длинная серия Рис. 2					Средняя серия Рис. 1	Длинная серия Рис. 2				
KD031D0070	—	0.700	8.0	38	3	KD031D00895	—	0.895	8.0	38	3	KD031D10088	—	1.088	10.0	38	3
—	KD032D0070		9.0			—	KD032D00895		10.0			—	KD032D10088		12.0	50	
KD031D0071	—	0.710	8.0	38	3	KD031D00897	—	0.897	8.0	38	3	KD031D0109	—	1.090	10.0	38	3
—	KD032D0071		10.0			—	KD032D00897		10.0			—	KD032D0109		12.0	50	
KD031D0072	—	0.720	8.0	38	3	KD031D0090	—	0.900	8.0	38	3	KD031D01093	—	1.093	10.0	38	3
—	KD032D0072		10.0			—	KD032D0090		10.0			—	KD032D01093		12.0	50	
KD031D0073	—	0.730	8.0	38	3	KD031D0091	—	0.910	8.0	38	3	KD031D01095	—	1.095	10.0	38	3
—	KD032D0073		10.0			—	KD032D0091		10.0			—	KD032D01095		12.0	50	
KD031D0074	—	0.740	8.0	38	3	KD031D0092	—	0.920	8.0	38	3	KD031D01097	—	1.097	10.0	38	3
—	KD032D0074		10.0			—	KD032D0092		10.0			—	KD032D01097		12.0	50	
KD031D0075	—	0.750	8.0	38	3	KD031D0093	—	0.930	8.0	38	3	KD031D0110	—	1.100	10.0	38	3
—	KD032D0075		10.0			—	KD032D0093		10.0			—	KD032D0110		12.0	50	
KD031D0076	—	0.760	8.0	38	3	KD031D0094	—	0.940	8.0	38	3	KD031D0111	—	1.110	10.0	38	3
—	KD032D0076		10.0			—	KD032D0094		10.0			—	KD032D0111		12.0	50	
KD031D0077	—	0.770	8.0	38	3	KD031D0095	—	0.950	8.0	38	3	KD031D0112	—	1.120	10.0	38	3
—	KD032D0077		10.0			—	KD032D0095		10.0			—	KD032D0112		12.0	50	
KD031D0078	—	0.780	8.0	38	3	KD031D0096	—	0.960	8.0	38	3	KD031D0113	—	1.130	10.0	38	3
—	KD032D0078		10.0			—	KD032D0096		10.0			—	KD032D0113		12.0	50	
KD031D0079	—	0.790	8.0	38	3	KD031D0097	—	0.970	8.0	38	3	KD031D0114	—	1.140	10.0	38	3
—	KD032D0079		10.0			—	KD032D0097		10.0			—	KD032D0114		12.0	50	
KD031D0080	—	0.800	8.0	38	3	KD031D0098	—	0.980	8.0	38	3	KD031D0115	—	1.150	10.0	38	3
—	KD032D0080		10.0			—	KD032D0098		10.0			—	KD032D0115		12.0	50	
KD031D0081	—	0.810	8.0	38	3	KD031D0099	—	0.990	8.0	38	3	KD031D0116	—	1.160	10.0	38	3
—	KD032D0081		10.0			—	KD032D0099		10.0			—	KD032D0116		12.0	50	
KD031D0082	—	0.820	8.0	38	3	KD031D0100	—	1.000	10.0	38	3	KD031D0117	—	1.170	10.0	38	3
—	KD032D0082		10.0			—	KD032D0100		12.0	50		—	KD032D0117		12.0	50	
KD031D0083	—	0.830	8.0	38	3	KD031D0101	—	1.010	10.0	38	3	KD031D0118	—	1.180	10.0	38	3
—	KD032D0083		10.0			—	KD032D0101		12.0	50		—	KD032D0118		12.0	50	
KD031D0084	—	0.840	8.0	38	3	KD031D0102	—	1.020	10.0	38	3	KD031D0119	—	1.190	10.0	38	3
—	KD032D0084		10.0			—	KD032D0102		12.0	50		—	KD032D0119		12.0	50	
KD031D0085	—	0.850	8.0	38	3	KD031D0103	—	1.030	10.0	38	3	KD031D0120	—	1.200	10.0	38	3
—	KD032D0085		10.0			—	KD032D0103		12.0	50		—	KD032D0120		15.0	50	
KD031D0086	—	0.860	8.0	38	3	KD031D0104	—	1.040	10.0	38	3	KD031D1210	—	1.210	10.0	38	3
—	KD032D0086		10.0			—	KD032D0104		12.0	50		—	KD032D0121		15.0	50	
KD031D0087	—	0.870	8.0	38	3	KD031D0105	—	1.050	10.0	38	3	KD031D0122	—	1.220	10.0	38	3
—	KD032D0087		10.0			—	KD032D0105		12.0	50		—	KD032D0122		15.0	50	
KD031D0088	—	0.880	8.0	38	3	KD031D0106	—	1.060	10.0	38	3	KD031D0123	—	1.230	10.0	38	3
—	KD032D0088		10.0			—	KD032D0106		12.0	50		—	KD032D0123		15.0	50	
KD031D00883	—	0.883	8.0	38	3	KD031D0107	—	1.070	10.0	38	3	KD031D0124	—	1.240	10.0	38	3
—	KD032D00883		10.0			—	KD032D0107		12.0	50		—	KD032D0124		15.0	50	
KD031D00885	—	0.885	8.0	38	3	KD031D0108	—	1.080	10.0	38	3	KD031D0125	—	1.250	10.0	38	3
—	KD032D00885		10.0			—	KD032D0108		12.0	50		—	KD032D0125		15.0	50	
KD031D00887	—	0.887	8.0	38	3	KD031D01083	—	1.083	10.0	38	3	KD031D01255	—	1.255	10.0	38	3
—	KD032D00887		10.0			—	KD032D01083		12.0	50		—	KD032D01255		15.0	50	
KD031D00888	—	0.888	8.0	38	3	KD031D01085	—	1.085	10.0	38	3	KD031D0126	—	1.260	10.0	38	3
—	KD032D00888		10.0			—	KD032D01085		12.0	50		—	KD032D0126		15.0	50	
KD031D0089	—	0.890	8.0	38	3	KD031D1087	—	1.087	10.0	38	3	KD031D01265	—	1.265	10.0	38	3
—	KD032D0089		10.0			—	KD032D01087		12.0	50		—	KD032D01265		15.0	50	

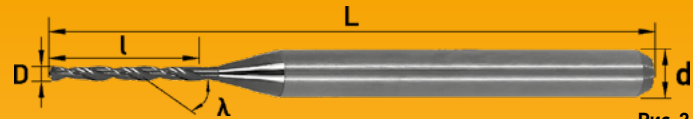

МИКРОСВЕРЛА ТВЕРДОСПЛАВНЫЕ. ДЛЯ ОБРАБОТКИ МЯГКИХ МАТЕРИАЛОВ, СПЛАВОВ ЦВЕТНЫХ МЕТАЛЛОВ, ПЛАСТИКОВ, ЛЕГКООБРАБАТЫВАЕМЫХ СТАЛЕЙ

СЕРИИ KD031, KD032

Продолжение таблицы

MG

0-0.003

$\lambda=35^\circ$



Рис. 1



Рис. 2

Артикулы					Артикулы					Артикулы							
Средняя серия Рис. 1	Длинная серия Рис. 2	D мм 0-0.003	l мм	L мм	d мм	Средняя серия Рис. 1	Длинная серия Рис. 2	D мм 0-0.003	l мм	L мм	d мм	Средняя серия Рис. 1	Длинная серия Рис. 2	D мм 0-0.003	l мм	L мм	d мм
KD031D0127	—	1.270	10.0	38	3	KD031D0148	—	1.480	10.0	38	3	KD031D0172	—	1.720	12.0	38	3
—	KD032D0127		15.0	50		—	KD032D0148		15.0	50		—	KD032D0172		20.0	50	
KD031D01280	—	1.280	10.0	38	3	KD031D0149	—	1.490	10.0	38	3	KD031D0173	—	1.730	12.0	38	3
—	KD032D0128		15.0	50		—	KD032D0149		15.0	50		—	KD032D0173		20.0	50	
KD031D01283	—	1.283	10.0	38	3	KD031D0150	—	1.500	10.0	38	3	KD031D0174	—	1.740	12.0	38	3
—	KD032D01283		15.0	50		—	KD032D0150		20.0	50		—	KD032D0174		20.0	50	
KD031D01285	—	1.285	10.0	38	3	KD031D0151	—	1.510	10.0	38	3	KD031D0175	—	1.750	12.0	38	3
—	KD032D01285		15.0	50		—	KD032D0151		20.0	50		—	KD032D0175		20.0	50	
KD031D0129	—	1.290	10.0	38	3	KD031D0152	—	1.520	10.0	38	3	KD031D0176	—	1.760	12.0	38	3
—	KD032D0129		15.0	50		—	KD032D0152		20.0	50		—	KD032D0176		20.0	50	
KD031D0130	—	1.300	10.0	38	3	KD031D0153	—	1.530	10.0	38	3	KD031D0177	—	1.770	12.0	38	3
—	KD032D0130		15.0	50		—	KD032D0153		20.0	50		—	KD032D0177		20.0	50	
KD031D0131	—	1.310	10.0	38	3	KD031D0154	—	1.540	10.0	38	3	KD031D0178	—	1.780	12.0	38	3
—	KD032D0131		15.0	50		—	KD032D0154		20.0	50		—	KD032D0178		20.0	50	
KD031D0132	—	1.320	10.0	38	3	KD031D0155	—	1.550	10.0	38	3	KD031D0179	—	1.790	12.0	38	3
—	KD032D0132		15.0	50		—	KD032D0155		20.0	50		—	KD032D0179		20.0	50	
KD031D0133	—	1.330	10.0	38	3	KD031D0156	—	1.560	10.0	38	3	KD031D0180	—	1.800	12.0	38	3
—	KD032D0133		15.0	50		—	KD032D0156		20.0	50		—	KD032D0180		20.0	50	
KD031D0134	—	1.340	10.0	38	3	KD031D0157	—	1.570	10.0	38	3	KD031D0181	—	1.810	12.0	38	3
—	KD032D0134		15.0	50		—	KD032D0157		20.0	50		—	KD032D0181		20.0	50	
KD031D0135	—	1.350	10.0	38	3	KD031D0158	—	1.580	10.0	38	3	KD031D0182	—	1.820	12.0	38	3
—	KD032D0135		15.0	50		—	KD032D0158		20.0	50		—	KD032D0182		20.0	50	
KD031D0136	—	1.360	10.0	38	3	KD031D0159	—	1.590	10.0	38	3	KD031D0183	—	1.830	12.0	38	3
—	KD032D0136		15.0	50		—	KD032D0159		20.0	50		—	KD032D0183		20.0	50	
KD031D0137	—	1.370	10.0	38	3	KD031D0160	—	1.600	12.0	38	3	KD031D0184	—	1.840	12.0	38	3
—	KD032D0137		15.0	50		—	KD032D0160		20.0	50		—	KD032D0184		20.0	50	
KD031D0138	—	1.380	10.0	38	3	KD031D0161	—	1.610	12.0	38	3	KD031D0185	—	1.850	12.0	38	3
—	KD032D0138		15.0	50		—	KD032D0161		20.0	50		—	KD032D0185		20.0	50	
KD031D0139	—	1.390	10.0	38	3	KD031D0162	—	1.620	12.0	38	3	KD031D0186	—	1.860	12.0	38	3
—	KD032D0139		15.0	50		—	KD032D0162		20.0	50		—	KD032D0186		20.0	50	
KD031D0140	—	1.400	10.0	38	3	KD031D0163	—	1.630	12.0	38	3	KD031D0187	—	1.870	12.0	38	3
—	KD032D0140		15.0	50		—	KD032D0163		20.0	50		—	KD032D0187		20.0	50	
KD031D0141	—	1.410	10.0	38	3	KD031D0164	—	1.640	12.0	38	3	KD031D0188	—	1.880	12.0	38	3
—	KD032D0141		15.0	50		—	KD032D0164		20.0	50		—	KD032D0188		20.0	50	
KD031D0142	—	1.420	10.0	38	3	KD031D0165	—	1.650	12.0	38	3	KD031D0189	—	1.890	12.0	38	3
—	KD032D0142		15.0	50		—	KD032D0165		20.0	50		—	KD032D0189		20.0	50	
KD031D0143	—	1.430	10.0	38	3	KD031D0166	—	1.660	12.0	38	3	KD031D0190	—	1.900	12.0	38	3
—	KD032D0143		15.0	50		—	KD032D0166		20.0	50		—	KD032D0190		20.0	50	
KD031D0144	—	1.440	10.0	38	3	KD031D0167	—	1.670	12.0	38	3	KD031D0191	—	1.910	12.0	38	3
—	KD032D0144		15.0	50		—	KD032D0167		20.0	50		—	KD032D0191		20.0	50	
KD031D0145	—	1.450	10.0	38	3	KD031D0168	—	1.680	12.0	38	3	KD031D0192	—	1.920	12.0	38	3
—	KD032D0145		15.0	50		—	KD032D0168		20.0	50		—	KD032D0192		20.0	50	
KD031D01455	—	1.455	10.0	38	3	KD031D0169	—	1.690	12.0	38	3	KD031D0193	—	1.930	12.0	38	3
—	KD032D01455		15.0	50		—	KD032D0169		20.0	50		—	KD032D0193		20.0	50	
KD031D0146	—	1.460	10.0	38	3	KD031D0170	—	1.700	12.0	38	3	KD031D0194	—	1.940	12.0	38	3
—	KD032D0146		15.0	50		—	KD032D0170		20.0	50		—	KD032D0194		20.0	50	
KD031D0147	—	1.470	10.0	38	3	KD031D0171	—	1.710	12.0	38	3	KD031D0195	—	1.950	12.0	38	3
—	KD032D0147		15.0	50		—	KD032D0171		20.0	50		—	KD032D0195		20.0	50	

Свёрла с размерами, отсутствующими в таблице, изготавливаются по запросу потребителя

МИКРОСВЕРЛА ТВЕРДОСПЛАВНЫЕ. ДЛЯ ОБРАБОТКИ МЯГКИХ МАТЕРИАЛОВ, СПЛАВОВ ЦВЕТНЫХ МЕТАЛЛОВ, ПЛАСТИКОВ, ЛЕГКООБРАБАТЫВАЕМЫХ СТАЛЕЙ

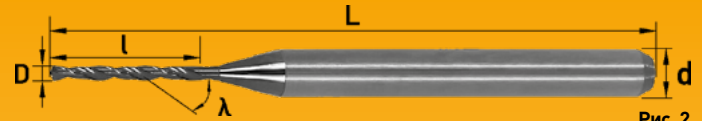

СЕРИИ KD031, KD032

Продолжение таблицы

MG

0-0.003

$\lambda=35^\circ$



Рис. 1



Рис. 2

Артикулы		D мм 0-0.003	l мм	L мм	d мм	Артикулы		D мм 0-0.003	l мм	L мм	d мм	Артикулы		D мм 0-0.003	l мм	L мм	d мм
Средняя серия Рис. 1	Длинная серия Рис. 2					Средняя серия Рис. 1	Длинная серия Рис. 2					Средняя серия Рис. 1	Длинная серия Рис. 2				
KD031D0196	—	1.960	12.0	38	3	KD031D0220	—	2.200	12.0	38	3	KD031D0245	—	2.450	12.0	38	3
—	KD032D0196		20.0	50		—	KD032D0220		25.0	60		—	KD032D0245		25.0	60	
KD031D0197	—	1.970	12.0	38	3	KD031D0221	—	2.210	12.0	38	3	KD031D0246	—	2.460	12.0	38	3
—	KD032D0197		20.0	50		—	KD032D0221		25.0	60		—	KD032D0246		25.0	60	
KD031D0198	—	1.980	12.0	38	3	KD031D0222	—	2.220	12.0	38	3	KD031D0247	—	2.470	12.0	38	3
—	KD032D0198		20.0	50		—	KD032D0222		25.0	60		—	KD032D0247		25.0	60	
KD031D0199	—	1.990	12.0	38	3	KD031D0223	—	2.230	12.0	38	3	KD031D0248	—	2.480	12.0	38	3
—	KD032D0199		20.0	50		—	KD032D0223		25.0	60		—	KD032D0248		25.0	60	
KD031D0200	—	2.000	12.0	38	3	KD031D0224	—	2.240	12.0	38	3	KD031D0249	—	2.490	12.0	38	3
—	KD032D0200		20.0	50		—	KD032D0224		25.0	60		—	KD032D0249		25.0	60	
KD031D0201	—	2.010	12.0	38	3	KD031D0225	—	2.250	12.0	38	3	KD031D0250	—	2.500	12.0	38	3
—	KD032D0201		25.0	60		—	KD032D0225		25.0	60		—	KD032D0250		25.0	60	
KD031D0202	—	2.020	12.0	38	3	KD031D0226	—	2.260	12.0	38	3	KD031D0251	—	2.510	12.0	38	3
—	KD032D0202		25.0	60		—	KD032D0226		25.0	60		—	KD032D0251		25.0	60	
KD031D0203	—	2.030	12.0	38	3	KD031D0227	—	2.270	12.0	38	3	KD031D0252	—	2.520	12.0	38	3
—	KD032D0203		25.0	60		—	KD032D0227		25.0	60		—	KD032D0252		25.0	60	
KD031D0204	—	2.040	12.0	38	3	KD031D0228	—	2.280	12.0	38	3	KD031D0253	—	2.530	12.0	38	3
—	KD032D0204		25.0	60		—	KD032D0228		25.0	60		—	KD032D0253		25.0	60	
KD031D0205	—	2.050	12.0	38	3	KD031D0229	—	2.290	12.0	38	3	KD031D0254	—	2.540	12.0	38	3
—	KD032D0205		25.0	60		—	KD032D0229		25.0	60		—	KD032D0254		25.0	60	
KD031D0206	—	2.060	12.0	38	3	KD031D0230	—	2.300	12.0	38	3	KD031D0255	—	2.550	12.0	38	3
—	KD032D0206		25.0	60		—	KD032D0230		25.0	60		—	KD032D0255		25.0	60	
KD031D0207	—	2.070	12.0	38	3	KD031D0231	—	2.310	12.0	38	3	KD031D0256	—	2.560	12.0	38	3
—	KD032D0207		25.0	60		—	KD032D0231		25.0	60		—	KD032D0256		25.0	60	
KD031D0208	—	2.080	12.0	38	3	KD031D0233	—	2.330	12.0	38	3	KD031D0257	—	2.570	12.0	38	3
—	KD032D0208		25.0	60		—	KD032D0233		25.0	60		—	KD032D0257		25.0	60	
KD031D0209	—	2.090	12.0	38	3	KD031D0234	—	2.340	12.0	38	3	KD031D0258	—	2.580	12.0	38	3
—	KD032D0209		25.0	60		—	KD032D0234		25.0	60		—	KD032D0258		25.0	60	
KD031D0210	—	2.100	12.0	38	3	KD031D0235	—	2.350	12.0	38	3	KD031D0259	—	2.590	12.0	38	3
—	KD032D0210		25.0	60		—	KD032D0235		25.0	60		—	KD032D0259		25.0	60	
KD031D0211	—	2.110	12.0	38	3	KD031D0236	—	2.360	12.0	38	3	KD031D0260	—	2.600	12.0	38	3
—	KD032D0211		25.0	60		—	KD032D0236		25.0	60		—	KD032D0260		25.0	60	
KD031D0212	—	2.120	12.0	38	3	KD031D0237	—	2.370	12.0	38	3	KD031D0261	—	2.610	12.0	38	3
—	KD032D0212		25.0	60		—	KD032D0237		25.0	60		—	KD032D0261		25.0	60	
KD031D0213	—	2.130	12.0	38	3	KD031D0238	—	2.380	12.0	38	3	KD031D0262	—	2.620	12.0	38	3
—	KD032D0213		25.0	60		—	KD032D0238		25.0	60		—	KD032D0262		25.0	60	
KD031D0214	—	2.140	12.0	38	3	KD031D0239	—	2.390	12.0	38	3	KD031D0263	—	2.630	12.0	38	3
—	KD032D0214		25.0	60		—	KD032D0239		25.0	60		—	KD032D0263		25.0	60	
KD031D0215	—	2.150	12.0	38	3	KD031D0240	—	2.400	12.0	38	3	KD031D0264	—	2.640	12.0	38	3
—	KD032D0215		25.0	60		—	KD032D0240		25.0	60		—	KD032D0264		25.0	60	
KD031D0216	—	2.160	12.0	38	3	KD031D0241	—	2.410	12.0	38	3	KD031D0265	—	2.650	12.0	38	3
—	KD032D0216		25.0	60		—	KD032D0241		25.0	60		—	KD032D0265		25.0	60	
KD031D0217	—	2.170	12.0	38	3	KD031D0242	—	2.420	12.0	38	3	KD031D0266	—	2.660	12.0	38	3
—	KD032D0217		25.0	60		—	KD032D0242		25.0	60		—	KD032D0266		25.0	60	
KD031D0218	—	2.180	12.0	38	3	KD031D0243	—	2.430	12.0	38	3	KD031D0267	—	2.670	12.0	38	3
—	KD032D0218		25.0	60		—	KD032D0243		25.0	60		—	KD032D0267		25.0	60	
KD031D0219	—	2.190	12.0	38	3	KD031D0244	—	2.440	12.0	38	3	KD031D0268	—	2.680	12.0	38	3
—	KD032D0219		25.0	60		—	KD032D0244		25.0	60		—	KD032D0268		25.0	60	

Свёрла с размерами, отсутствующими в таблице, изготавливаются по запросу потребителя

СЕРИИ KD031, KD032

Окончание таблицы

MG 0-0.003 $\lambda=35^\circ$ 120°

P M K N S H



Рис. 1



Рис. 2

Артикулы		D мм 0-0.003	l мм	L мм	d мм	Артикулы		D мм 0-0.003	l мм	L мм	d мм	Артикулы		D мм 0-0.003	l мм	L мм	d мм
Средняя серия Рис. 1	Длинная серия Рис. 2					Средняя серия Рис. 1	Длинная серия Рис. 2					Средняя серия Рис. 1	Длинная серия Рис. 2				
KD031D0269	—	2.690	12.0	38	3	KD031D0279	—	2.790	12.0	38	3	KD031D0290	—	2.900	12.0	38	3
—	KD032D0269		25.0	60		—	KD032D0279		25.0	60		—	KD032D0290		25.0	60	
KD031D0270	—	2.700	12.0	38	3	KD031D0280	—	2.800	12.0	38	3	KD031D0291	—	2.910	12.0	38	3
—	KD032D0270		25.0	60		—	KD032D0280		25.0	60		—	KD032D0291		25.0	60	
KD031D0271	—	2.710	12.0	38	3	KD031D0281	—	2.810	12.0	38	3	KD031D0292	—	2.920	12.0	38	3
—	KD032D0271		25.0	60		—	KD032D0281		25.0	60		—	KD032D0292		25.0	60	
KD031D0272	—	2.720	12.0	38	3	KD031D0282	—	2.820	12.0	38	3	KD031D0293	—	2.930	12.0	38	3
—	KD032D0272		25.0	60		—	KD032D0282		25.0	60		—	KD032D0293		25.0	60	
KD031D0273	—	2.730	12.0	38	3	KD031D0283	—	2.830	12.0	38	3	KD031D0294	—	2.940	12.0	38	3
—	KD032D0273		25.0	60		—	KD032D0283		25.0	60		—	KD032D0294		25.0	60	
KD031D0274	—	2.740	12.0	38	3	KD031D0284	—	2.840	12.0	38	3	KD031D0295	—	2.950	12.0	38	3
—	KD032D0274		25.0	60		—	KD032D0284		25.0	60		—	KD032D0295		25.0	60	
KD031D0275	—	2.750	12.0	38	3	KD031D0285	—	2.850	12.0	38	3	KD031D0296	—	2.960	12.0	38	3
—	KD032D0275		25.0	60		—	KD032D0285		25.0	60		—	KD032D0296		25.0	60	
KD031D0276	—	2.760	12.0	38	3	KD031D0286	—	2.860	12.0	38	3	KD031D0297	—	2.970	12.0	38	3
—	KD032D0276		25.0	60		—	KD032D0286		25.0	60		—	KD032D0297		25.0	60	
KD031D0277	—	2.770	12.0	38	3	KD031D0287	—	2.870	12.0	38	3	KD031D0298	—	2.980	12.0	38	3
—	KD032D0277		25.0	60		—	KD032D0287		25.0	60		—	KD032D0298		25.0	60	
KD031D0278	—	2.780	12.0	38	3	KD031D0288	—	2.880	12.0	38	3	KD031D0299	—	2.990	12.0	38	3
—	KD032D0278		25.0	60		—	KD032D0288		25.0	60		—	KD032D0299		25.0	60	
KD031D02785	—	2.785	12.0	38	3	KD031D0289	—	2.890	12.0	38	3	KD031D0300	—	3.000	12.0	38	3
—	KD032D02785		25.0	60		—	KD032D0289		25.0	60		—	KD032D0300		25.0	60	

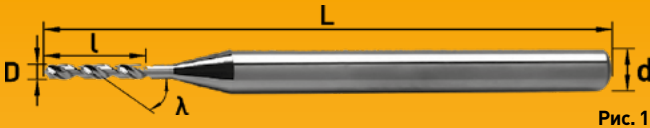

5.2. СВЁРЛА СО СМЕННЫМИ ГОЛОВКАМИ

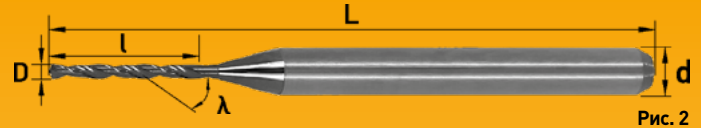
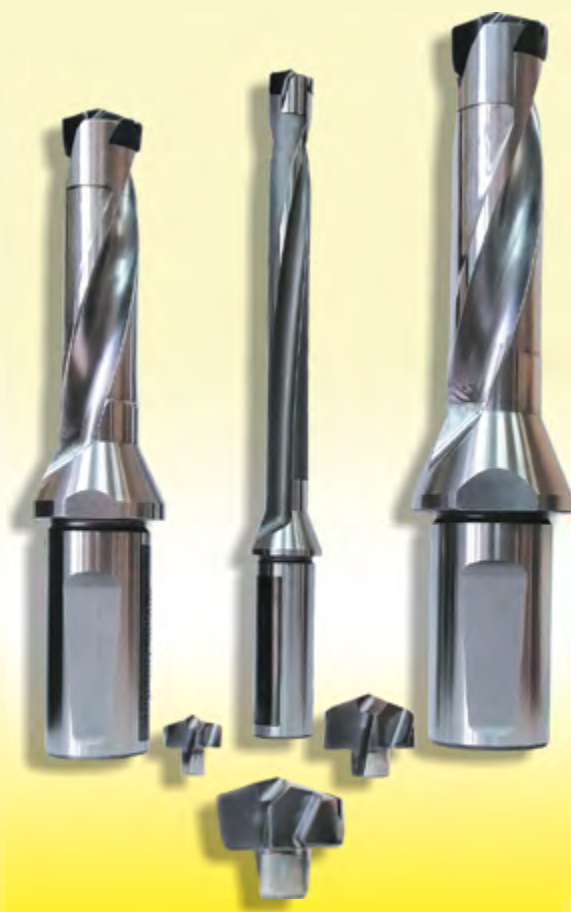
СВЁРЛА СО СМЕННЫМИ ГОЛОВКАМИ

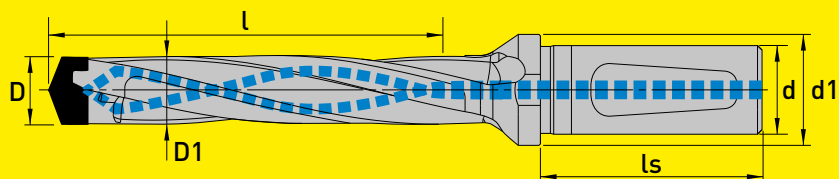

Диапазон сверления D	Артикул	Глубина сверления	l мм	ls мм	D1 мм	d1 мм	d мм
8.0-8.9	FD08008901E12H	1.5D	16	45	7.8	16	12
	FD08008903E12H	3.0D	32	45	7.8	16	12
	FD08008905E12H	5.0D	50	45	7.8	16	12
	FD08008908E12H	8.0D	76	45	7.6	16	12
9.0-9.9	FD09009901E12H	1.5D	18	45	8.8	16	12
	FD09009903E12H	3.0D	35	45	8.8	16	12
	FD09009905E12H	5.0D	55	45	8.8	16	12
	FD09009908E12H	8.0D	85	45	8.6	16	12
10.0-10.9	FD10010901E16H	1.5D	20	48	9.8	20	16
	FD10010903E16H	3.0D	39	48	9.8	20	16
	FD10010905E16H	5.0D	60	48	9.8	20	16
	FD10010908E16H	8.0D	93	48	9.6	20	16
11.0-11.9	FD11011901E16H	1.5D	22	48	10.8	20	16
	FD11011903E16H	3.0D	42	48	10.8	20	16
	FD11011905E16H	5.0D	66	48	10.8	20	16
	FD11011908E16H	8.0D	102	48	10.6	20	16
12.0-12.9	FD12012901E16H	1.5D	24	48	11.8	20	16
	FD12012903E16H	3.0D	45	48	11.8	20	16
	FD12012905E16H	5.0D	71	48	11.8	20	16
	FD12012908E16H	8.0D	110	48	11.6	20	16
	FD12012912E16H	12.0D	162	48	11.6	20	16
13.0-13.9	FD13013901E16H	1.5D	25	48	12.8	20	16
	FD13013903E16H	3.0D	49	48	12.8	20	16
	FD13013905E16H	5.0D	77	48	12.8	20	16
	FD13013908E16H	8.0D	119	48	12.6	20	16
	FD13013912E16H	12.0D	175	48	12.6	20	16
14.0-14.9	FD14014901E16H	1.5D	27	48	13.8	20	16
	FD14014903E16H	3.0D	53	48	13.8	20	16
	FD14014905E16H	5.0D	82	48	13.8	20	16
	FD14014908E16H	8.0D	127	48	13.6	20	16
	FD14014912E16H	12.0D	187	48	13.6	20	16
15.0-15.9	FD15015901E20H	1.5D	29	50	14.8	25	20
	FD15015903E20H	3.0D	56	50	14.8	25	20
	FD15015905E20H	5.0D	88	50	14.8	25	20
	FD15015908E20H	8.0D	136	50	14.6	25	20
	FD15015912E20H	12.0D	200	50	14.6	25	20
16.0-16.9	FD16016901E20H	1.5D	30	50	15.8	25	20
	FD16016903E20H	3.0D	60	50	15.8	25	20
	FD16016905E20H	5.0D	93	50	15.8	25	20
	FD16016908E20H	8.0D	144	50	15.6	25	20
	FD16016912E20H	12.0D	212	50	15.6	25	20
17.0-17.9	FD17017901E20H	1.5D	32	50	16.8	25	20
	FD17017903E20H	3.0D	63	50	16.8	25	20
	FD17017905E20H	5.0D	99	50	16.8	25	20
	FD17017908E20H	8.0D	153	50	16.6	25	20
	FD17017912E20H	12.0D	225	50	16.6	25	20

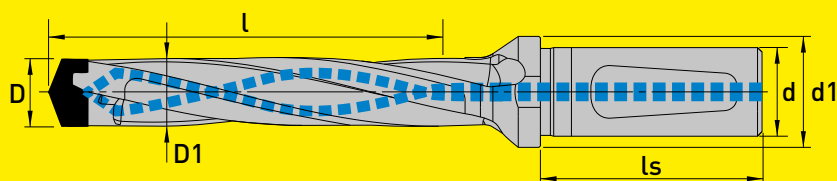

Диапазон сверления	Артикул	Глубина сверления	l мм	ls мм	D1 мм	d1 мм	d мм
18.0–18.9	FD18018901E25H	1.5D	34	56	17.8	32	25
	FD18018903E25H	3.0D	66	56	17.8	32	25
	FD18018905E25H	5.0D	104	56	17.8	32	25
	FD18018908E25H	8.0D	161	56	17.6	32	25
	FD18018912E25H	12.0D	237	56	17.6	32	25
19.0–19.9	FD19019901E25H	1.5D	36	56	18.8	32	25
	FD19019903E25H	3.0D	70	56	18.8	32	25
	FD19019905E25H	5.0D	110	56	18.8	32	25
	FD19019908E25H	8.0D	170	56	18.6	32	25
	FD19019912E25H	12.0D	250	56	18.6	32	25
20.0–20.9	FD20020901E25H	1.5D	38	56	19.8	32	25
	FD20020903E25H	3.0D	73	56	19.8	32	25
	FD20020905E25H	5.0D	115	56	19.8	32	25
	FD20020908E25H	8.0D	178	56	19.6	32	25
	FD20020912E25H	12.0D	262	56	19.6	32	25
21.0–21.9	FD21021901E25H	1.5D	40	56	20.8	32	25
	FD21021903E25H	3.0D	77	56	20.8	32	25
	FD21021905E25H	5.0D	121	56	20.8	32	25
	FD21021908E25H	8.0D	187	56	20.6	32	25
	FD21021912E25H	12.0D	275	56	20.6	32	25
22.0–22.9	FD22022901E25H	1.5D	42	56	21.8	32	25
	FD22022903E25H	3.0D	80	56	21.8	32	25
	FD22022905E25H	5.0D	126	56	21.8	32	25
	FD22022908E25H	8.0D	195	56	21.6	32	25
	FD22022912E25H	12.0D	287	56	21.6	32	25
23.0–23.9	FD23023901E32H	1.5D	43	60	22.8	42	32
	FD23023903E32H	3.0D	84	60	22.8	42	32
	FD23023905E32H	5.0D	132	60	22.8	42	32
	FD23023908E32H	8.0D	204	60	22.6	42	32
	FD23023912E32H	12.0D	300	60	22.6	42	32
24.0–24.9	FD24024901E32H	1.5D	45	60	23.8	42	32
	FD24024903E32H	3.0D	88	60	23.8	42	32
	FD24024905E32H	5.0D	137	60	23.8	42	32
	FD24024908E32H	8.0D	212	60	23.6	42	32
	FD24024912E32H	12.0D	313	60	23.6	42	32
25.0–26.0	FD25026001E32H	1.5D	47	60	24.8	42	32
	FD25026003E32H	3.0D	91	60	24.8	42	32
	FD25026005E32H	5.0D	143	60	24.8	42	32
	FD25026008E32H	8.0D	221	60	24.6	42	32
	FD25026012E32H	12.0D	325	60	24.6	42	32

ТИПЫ СВЕРЛИЛЬНЫХ ГОЛОВОК

	ТИП	Применение
FHSA		<p>Общее применение для отверстий глубиной до 5D.</p> <p>Основное применение: стали, легированные стали, чугуны с шаровидным графитом.</p> <p>Возможное применение: нержавеющие стали.</p>
NEW FHSM		<p>Специальная самоцентрирующаяся геометрия с низкими усилиями резания.</p> <p>Основное применение: обработка нержавеющей сталей, титановых сплавов, жаропрочных сплавов на основе никеля, магниевых сплавов и прочих труднообрабатываемых материалов.</p>
FHSB		<p>Основное применение: серые чугуны и чугуны с шаровидным графитом.</p>
FHRA		<p>Общее применение для отверстий глубиной 8D и более.</p> <p>Основное применение: стали, легированные стали, чугуны с шаровидным графитом.</p> <p>При сверлении отверстий 8D и более рекомендуется работать по предварительно просверленному отверстию.</p> <p>Возможное применение: нержавеющие стали.</p>
NEW FHRB		<p>Общее применение для отверстий глубиной 8D и более.</p> <p>Модернизированная головка на основе FHRA, имеет стружколомающие канавки на режущей кромке для лучшего формирования и отвода стружки.</p> <p>При сверлении отверстий 8D и более рекомендуется работать по предварительно просверленному отверстию.</p> <p>Возможное применение: нержавеющие стали.</p>
FHFA		<p>Для формирования плоского дна в заранее просверленных глухих отверстиях. Не рекомендуется обработка труднообрабатываемых материалов.</p>

ГОЛОВКИ СВЕРЛИЛЬНЫЕ СМЕННЫЕ

Диапазон сверления	D мм	тип FHSA	тип FHSM	тип FHSB	тип FHRA	тип FHRB	тип FHFA	S мм		Тип совместимого корпуса сверла
		Артикул	Артикул	Артикул	Артикул	Артикул	Артикул	FHSA FHSB FHRB	FHSM FHRA FHFA	
8.0–8.9	8.0	FHSA-0800	FHSM-0800	FHSB-0800	FHRA-0800	FHRB-0800	FHFA-0800	5.4	4.0	FD080089...
	8.1	FHSA-0810	FHSM-0810	FHSB-0810	FHRA-0810	FHRB-0810	FHFA-0810			
	8.2	FHSA-0820	FHSM-0820	FHSB-0820	FHRA-0820	FHRB-0820	FHFA-0820			
	8.3	FHSA-0830	FHSM-0830	FHSB-0830	FHRA-0830	FHRB-0830	FHFA-0830			
	8.4	FHSA-0840	FHSM-0840	FHSB-0840	FHRA-0840	FHRB-0840	FHFA-0840			
	8.5	FHSA-0850	FHSM-0850	FHSB-0850	FHRA-0850	FHRB-0850	FHFA-0850			
	8.6	FHSA-0860	FHSM-0860	FHSB-0860	FHRA-0860	FHRB-0860	FHFA-0860			
	8.7	FHSA-0870	FHSM-0870	FHSB-0870	FHRA-0870	FHRB-0870	FHFA-0870			
	8.8	FHSA-0880	FHSM-0880	FHSB-0880	FHRA-0880	FHRB-0880	FHFA-0880			
8.9	FHSA-0890	FHSM-0890	FHSB-0890	FHRA-0890	FHRB-0890	FHFA-0890				
9.0–9.9	9.0	FHSA-0900	FHSM-0900	FHSB-0900	FHRA-0900	FHRB-0900	FHFA-0900	5.8	4.2	FD090099...
	9.1	FHSA-0910	FHSM-0910	FHSB-0910	FHRA-0910	FHRB-0910	FHFA-0910			
	9.2	FHSA-0920	FHSM-0920	FHSB-0920	FHRA-0920	FHRB-0920	FHFA-0920			
	9.3	FHSA-0930	FHSM-0930	FHSB-0930	FHRA-0930	FHRB-0930	FHFA-0930			
	9.4	FHSA-0940	FHSM-0940	FHSB-0940	FHRA-0940	FHRB-0940	FHFA-0940			
	9.5	FHSA-0950	FHSM-0950	FHSB-0950	FHRA-0950	FHRB-0950	FHFA-0950			
	9.6	FHSA-0960	FHSM-0960	FHSB-0960	FHRA-0960	FHRB-0960	FHFA-0960			
	9.7	FHSA-0970	FHSM-0970	FHSB-0970	FHRA-0970	FHRB-0970	FHFA-0970			
	9.8	FHSA-0980	FHSM-0980	FHSB-0980	FHRA-0980	FHRB-0980	FHFA-0980			
9.9	FHSA-0990	FHSM-0990	FHSB-0990	FHRA-0990	FHRB-0990	FHFA-0990				
10.0–10.9	10.0	FHSA-1000	FHSM-1000	FHSB-1000	FHRA-1000	FHRB-1000	FHFA-1000	6.2	4.4	FD100109...
	10.1	FHSA-1010	FHSM-1010	FHSB-1010	FHRA-1010	FHRB-1010	FHFA-1010			
	10.2	FHSA-1020	FHSM-1020	FHSB-1020	FHRA-1020	FHRB-1020	FHFA-1020			
	10.3	FHSA-1030	FHSM-1030	FHSB-1030	FHRA-1030	FHRB-1030	FHFA-1030			
	10.4	FHSA-1040	FHSM-1040	FHSB-1040	FHRA-1040	FHRB-1040	FHFA-1040			
	10.5	FHSA-1050	FHSM-1050	FHSB-1050	FHRA-1050	FHRB-1050	FHFA-1050			
	10.6	FHSA-1060	FHSM-1060	FHSB-1060	FHRA-1060	FHRB-1060	FHFA-1060			
	10.7	FHSA-1070	FHSM-1070	FHSB-1070	FHRA-1070	FHRB-1070	FHFA-1070			
	10.8	FHSA-1080	FHSM-1080	FHSB-1080	FHRA-1080	FHRB-1080	FHFA-1080			
10.9	FHSA-1090	FHSM-1090	FHSB-1090	FHRA-1090	FHRB-1090	FHFA-1090				
11.0–11.9	11.0	FHSA-1100	FHSM-1100	FHSB-1100	FHRA-1100	FHRB-1100	FHFA-1100	6.6	4.5	FD110119...
	11.1	FHSA-1110	FHSM-1110	FHSB-1110	FHRA-1110	FHRB-1110	FHFA-1110			
	11.2	FHSA-1120	FHSM-1120	FHSB-1120	FHRA-1120	FHRB-1120	FHFA-1120			
	11.3	FHSA-1130	FHSM-1130	FHSB-1130	FHRA-1130	FHRB-1130	FHFA-1130			
	11.4	FHSA-1140	FHSM-1140	FHSB-1140	FHRA-1140	FHRB-1140	FHFA-1140			
	11.5	FHSA-1150	FHSM-1150	FHSB-1150	FHRA-1150	FHRB-1150	FHFA-1150			
	11.6	FHSA-1160	FHSM-1160	FHSB-1160	FHRA-1160	FHRB-1160	FHFA-1160			
	11.7	FHSA-1170	FHSM-1170	FHSB-1170	FHRA-1170	FHRB-1170	FHFA-1170			
	11.8	FHSA-1180	FHSM-1180	FHSB-1180	FHRA-1180	FHRB-1180	FHFA-1180			
11.9	FHSA-1190	FHSM-1190	FHSB-1190	FHRA-1190	FHRB-1190	FHFA-1190				
12.0–12.9	12.0	FHSA-1200	FHSM-1200	FHSB-1200	FHRA-1200	FHRB-1200	FHFA-1200	7.0	4.8	FD120129...
	12.1	FHSA-1210	FHSM-1210	FHSB-1210	FHRA-1210	FHRB-1210	FHFA-1210			
	12.2	FHSA-1220	FHSM-1220	FHSB-1220	FHRA-1220	FHRB-1220	FHFA-1220			
	12.3	FHSA-1230	FHSM-1230	FHSB-1230	FHRA-1230	FHRB-1230	FHFA-1230			
	12.4	FHSA-1240	FHSM-1240	FHSB-1240	FHRA-1240	FHRB-1240	FHFA-1240			
	12.5	FHSA-1250	FHSM-1250	FHSB-1250	FHRA-1250	FHRB-1250	FHFA-1250			
	12.6	FHSA-1260	FHSM-1260	FHSB-1260	FHRA-1260	FHRB-1260	FHFA-1260			
	12.7	FHSA-1270	FHSM-1270	FHSB-1270	FHRA-1270	FHRB-1270	FHFA-1270			
	12.8	FHSA-1280	FHSM-1280	FHSB-1280	FHRA-1280	FHRB-1280	FHFA-1280			
12.9	FHSA-1290	FHSM-1290	FHSB-1290	FHRA-1290	FHRB-1290	FHFA-1290				
13.0–13.9	13.0	FHSA-1300	FHSM-1300	FHSB-1300	FHRA-1300	FHRB-1300	FHFA-1300	7.6	5.1	FD130139...
	13.1	FHSA-1310	FHSM-1310	FHSB-1310	FHRA-1310	FHRB-1310	FHFA-1310			
	13.2	FHSA-1320	FHSM-1320	FHSB-1320	FHRA-1320	FHRB-1320	FHFA-1320			
	13.3	FHSA-1330	FHSM-1330	FHSB-1330	FHRA-1330	FHRB-1330	FHFA-1330			
	13.4	FHSA-1340	FHSM-1340	FHSB-1340	FHRA-1340	FHRB-1340	FHFA-1340			
	13.5	FHSA-1350	FHSM-1350	FHSB-1350	FHRA-1350	FHRB-1350	FHFA-1350			
	13.6	FHSA-1360	FHSM-1360	FHSB-1360	FHRA-1360	FHRB-1360	FHFA-1360			
	13.7	FHSA-1370	FHSM-1370	FHSB-1370	FHRA-1370	FHRB-1370	FHFA-1370			
	13.8	FHSA-1380	FHSM-1380	FHSB-1380	FHRA-1380	FHRB-1380	FHFA-1380			
13.9	FHSA-1390	FHSM-1390	FHSB-1390	FHRA-1390	FHRB-1390	FHFA-1390				

Продолжение таблицы



ГОЛОВКИ СВЕРЛИЛЬНЫЕ СМЕННЫЕ

Диапазон сверления	D мм	тип FHSA	тип FHSM	тип FHSB	тип FHRA	тип FHRB	тип FHFA	S мм		Тип совместимого корпуса сверла
		Артикул	Артикул	Артикул	Артикул	Артикул	Артикул	FHSA FHSB	FHSM FHRA FHRB	
14.0–14.9	14.0	FHSA-1400	FHSM-1400	FHSB-1400	FHRA-1400	FHRB-1400	FHFA-1400	8.1	5.5	FD140149...
	14.1	FHSA-1410	FHSM-1410	FHSB-1410	FHRA-1410	FHRB-1410	FHFA-1410			
	14.2	FHSA-1420	FHSM-1420	FHSB-1420	FHRA-1420	FHRB-1420	FHFA-1420			
	14.3	FHSA-1430	FHSM-1430	FHSB-1430	FHRA-1430	FHRB-1430	FHFA-1430			
	14.4	FHSA-1440	FHSM-1440	FHSB-1440	FHRA-1440	FHRB-1440	FHFA-1440			
	14.5	FHSA-1450	FHSM-1450	FHSB-1450	FHRA-1450	FHRB-1450	FHFA-1450			
	14.6	FHSA-1460	FHSM-1460	FHSB-1460	FHRA-1460	FHRB-1460	FHFA-1460			
	14.7	FHSA-1470	FHSM-1470	FHSB-1470	FHRA-1470	FHRB-1470	FHFA-1470			
	14.8	FHSA-1480	FHSM-1480	FHSB-1480	FHRA-1480	FHRB-1480	FHFA-1480			
	14.9	FHSA-1490	FHSM-1490	FHSB-1490	FHRA-1490	FHRB-1490	FHFA-1490			
15.0–15.9	15.0	FHSA-1500	FHSM-1500	FHSB-1500	FHRA-1500	FHRB-1500	FHFA-1500	8.7	5.9	FD150159...
	15.1	FHSA-1510	FHSM-1510	FHSB-1510	FHRA-1510	FHRB-1510	FHFA-1510			
	15.2	FHSA-1520	FHSM-1520	FHSB-1520	FHRA-1520	FHRB-1520	FHFA-1520			
	15.3	FHSA-1530	FHSM-1530	FHSB-1530	FHRA-1530	FHRB-1530	FHFA-1530			
	15.4	FHSA-1540	FHSM-1540	FHSB-1540	FHRA-1540	FHRB-1540	FHFA-1540			
	15.5	FHSA-1550	FHSM-1550	FHSB-1550	FHRA-1550	FHRB-1550	FHFA-1550			
	15.6	FHSA-1560	FHSM-1560	FHSB-1560	FHRA-1560	FHRB-1560	FHFA-1560			
	15.7	FHSA-1570	FHSM-1570	FHSB-1570	FHRA-1570	FHRB-1570	FHFA-1570			
	15.8	FHSA-1580	FHSM-1580	FHSB-1580	FHRA-1580	FHRB-1580	FHFA-1580			
	15.9	FHSA-1590	FHSM-1590	FHSB-1590	FHRA-1590	FHRB-1590	FHFA-1590			
16.0–16.9	16.0	FHSA-1600	FHSM-1600	FHSB-1600	FHRA-1600	FHRB-1600	FHFA-1600	9.3	6.3	FD160169...
	16.1	FHSA-1610	FHSM-1610	FHSB-1610	FHRA-1610	FHRB-1610	FHFA-1610			
	16.2	FHSA-1620	FHSM-1620	FHSB-1620	FHRA-1620	FHRB-1620	FHFA-1620			
	16.3	FHSA-1630	FHSM-1630	FHSB-1630	FHRA-1630	FHRB-1630	FHFA-1630			
	16.4	FHSA-1640	FHSM-1640	FHSB-1640	FHRA-1640	FHRB-1640	FHFA-1640			
	16.5	FHSA-1650	FHSM-1650	FHSB-1650	FHRA-1650	FHRB-1650	FHFA-1650			
	16.6	FHSA-1660	FHSM-1660	FHSB-1660	FHRA-1660	FHRB-1660	FHFA-1660			
	16.7	FHSA-1670	FHSM-1670	FHSB-1670	FHRA-1670	FHRB-1670	FHFA-1670			
	16.8	FHSA-1680	FHSM-1680	FHSB-1680	FHRA-1680	FHRB-1680	FHFA-1680			
	16.9	FHSA-1690	FHSM-1690	FHSB-1690	FHRA-1690	FHRB-1690	FHFA-1690			
17.0–17.9	17.0	FHSA-1700	FHSM-1700	FHSB-1700	FHRA-1700	FHRB-1700	FHFA-1700	9.9	6.6	FD170179...
	17.1	FHSA-1710	FHSM-1710	FHSB-1710	FHRA-1710	FHRB-1710	FHFA-1710			
	17.2	FHSA-1720	FHSM-1720	FHSB-1720	FHRA-1720	FHRB-1720	FHFA-1720			
	17.3	FHSA-1730	FHSM-1730	FHSB-1730	FHRA-1730	FHRB-1730	FHFA-1730			
	17.4	FHSA-1740	FHSM-1740	FHSB-1740	FHRA-1740	FHRB-1740	FHFA-1740			
	17.5	FHSA-1750	FHSM-1750	FHSB-1750	FHRA-1750	FHRB-1750	FHFA-1750			
	17.6	FHSA-1760	FHSM-1760	FHSB-1760	FHRA-1760	FHRB-1760	FHFA-1760			
	17.7	FHSA-1770	FHSM-1770	FHSB-1770	FHRA-1770	FHRB-1770	FHFA-1770			
	17.8	FHSA-1780	FHSM-1780	FHSB-1780	FHRA-1780	FHRB-1780	FHFA-1780			
	17.9	FHSA-1790	FHSM-1790	FHSB-1790	FHRA-1790	FHRB-1790	FHFA-1790			
18.0–18.9	18.0	FHSA-1800	FHSM-1800	FHSB-1800	FHRA-1800	FHRB-1800	FHFA-1800	10.5	6.9	FD180189...
	18.1	FHSA-1810	FHSM-1810	FHSB-1810	FHRA-1810	FHRB-1810	FHFA-1810			
	18.2	FHSA-1820	FHSM-1820	FHSB-1820	FHRA-1820	FHRB-1820	FHFA-1820			
	18.3	FHSA-1830	FHSM-1830	FHSB-1830	FHRA-1830	FHRB-1830	FHFA-1830			
	18.4	FHSA-1840	FHSM-1840	FHSB-1840	FHRA-1840	FHRB-1840	FHFA-1840			
	18.5	FHSA-1850	FHSM-1850	FHSB-1850	FHRA-1850	FHRB-1850	FHFA-1850			
	18.6	FHSA-1860	FHSM-1860	FHSB-1860	FHRA-1860	FHRB-1860	FHFA-1860			
	18.7	FHSA-1870	FHSM-1870	FHSB-1870	FHRA-1870	FHRB-1870	FHFA-1870			
	18.8	FHSA-1880	FHSM-1880	FHSB-1880	FHRA-1880	FHRB-1880	FHFA-1880			
	18.9	FHSA-1890	FHSM-1890	FHSB-1890	FHRA-1890	FHRB-1890	FHFA-1890			
19.0–19.9	19.0	FHSA-1900	FHSM-1900	FHSB-1900	FHRA-1900	FHRB-1900	FHFA-1900	11.0	7.2	FD190199...
	19.1	FHSA-1910	FHSM-1910	FHSB-1910	FHRA-1910	FHRB-1910	FHFA-1910			
	19.2	FHSA-1920	FHSM-1920	FHSB-1920	FHRA-1920	FHRB-1920	FHFA-1920			
	19.3	FHSA-1930	FHSM-1930	FHSB-1930	FHRA-1930	FHRB-1930	FHFA-1930			
	19.4	FHSA-1940	FHSM-1940	FHSB-1940	FHRA-1940	FHRB-1940	FHFA-1940			
	19.5	FHSA-1950	FHSM-1950	FHSB-1950	FHRA-1950	FHRB-1950	FHFA-1950			
	19.6	FHSA-1960	FHSM-1960	FHSB-1960	FHRA-1960	FHRB-1960	FHFA-1960			
	19.7	FHSA-1970	FHSM-1970	FHSB-1970	FHRA-1970	FHRB-1970	FHFA-1970			
	19.8	FHSA-1980	FHSM-1980	FHSB-1980	FHRA-1980	FHRB-1980	FHFA-1980			
	19.9	FHSA-1990	FHSM-1990	FHSB-1990	FHRA-1990	FHRB-1990	FHFA-1990			

Окончание таблицы

ГОЛОВКИ СВЕРЛИЛЬНЫЕ СМЕННЫЕ

Диапазон сверления	D мм	тип FHSA	тип FHSM	тип FHSB	тип FHRA	тип FHRB	тип FHFA	S мм		Тип совместимого корпуса сверла
		Артикул	Артикул	Артикул	Артикул	Артикул	Артикул	FHSA FHSB FHRB	FHSM FHRA FHFA	
20.0-20.9	20.0	FHSA-2000	FHSM-2000	FHSB-2000	FHRA-2000	FHRB-2000	FHFA-2000	11.6	8.2	FD200209...
	20.1	FHSA-2010	FHSM-2010	FHSB-2010	FHRA-2010	FHRB-2010	FHFA-2010			
	20.2	FHSA-2020	FHSM-2020	FHSB-2020	FHRA-2020	FHRB-2020	FHFA-2020			
	20.3	FHSA-2030	FHSM-2030	FHSB-2030	FHRA-2030	FHRB-2030	FHFA-2030			
	20.4	FHSA-2040	FHSM-2040	FHSB-2040	FHRA-2040	FHRB-2040	FHFA-2040			
	20.5	FHSA-2050	FHSM-2050	FHSB-2050	FHRA-2050	FHRB-2050	FHFA-2050			
	20.6	FHSA-2060	FHSM-2060	FHSB-2060	FHRA-2060	FHRB-2060	FHFA-2060			
	20.7	FHSA-2070	FHSM-2070	FHSB-2070	FHRA-2070	FHRB-2070	FHFA-2070			
	20.8	FHSA-2080	FHSM-2080	FHSB-2080	FHRA-2080	FHRB-2080	FHFA-2080			
	20.9	FHSA-2090	FHSM-2090	FHSB-2090	FHRA-2090	FHRB-2090	FHFA-2090			
21.0-21.9	21.0	FHSA-2100	FHSM-2100	FHSB-2100	FHRA-2100	FHRB-2100	FHFA-2100	12.1	8.6	FD210219...
	21.1	FHSA-2110	FHSM-2110	FHSB-2110	FHRA-2110	FHRB-2110	FHFA-2110			
	21.2	FHSA-2120	FHSM-2120	FHSB-2120	FHRA-2120	FHRB-2120	FHFA-2120			
	21.3	FHSA-2130	FHSM-2130	FHSB-2130	FHRA-2130	FHRB-2130	FHFA-2130			
	21.4	FHSA-2140	FHSM-2140	FHSB-2140	FHRA-2140	FHRB-2140	FHFA-2140			
	21.5	FHSA-2150	FHSM-2150	FHSB-2150	FHRA-2150	FHRB-2150	FHFA-2150			
	21.6	FHSA-2160	FHSM-2160	FHSB-2160	FHRA-2160	FHRB-2160	FHFA-2160			
	21.7	FHSA-2170	FHSM-2170	FHSB-2170	FHRA-2170	FHRB-2170	FHFA-2170			
	21.8	FHSA-2180	FHSM-2180	FHSB-2180	FHRA-2180	FHRB-2180	FHFA-2180			
	21.9	FHSA-2190	FHSM-2190	FHSB-2190	FHRA-2190	FHRB-2190	FHFA-2190			
22.0-22.9	22.0	FHSA-2200	FHSM-2200	FHSB-2200	FHRA-2200	FHRB-2200	FHFA-2200	12.7	8.9	FD220229...
	22.1	FHSA-2210	FHSM-2210	FHSB-2210	FHRA-2210	FHRB-2210	FHFA-2210			
	22.2	FHSA-2220	FHSM-2220	FHSB-2220	FHRA-2220	FHRB-2220	FHFA-2220			
	22.3	FHSA-2230	FHSM-2230	FHSB-2230	FHRA-2230	FHRB-2230	FHFA-2230			
	22.4	FHSA-2240	FHSM-2240	FHSB-2240	FHRA-2240	FHRB-2240	FHFA-2240			
	22.5	FHSA-2250	FHSM-2250	FHSB-2250	FHRA-2250	FHRB-2250	FHFA-2250			
	22.6	FHSA-2260	FHSM-2260	FHSB-2260	FHRA-2260	FHRB-2260	FHFA-2260			
	22.7	FHSA-2270	FHSM-2270	FHSB-2270	FHRA-2270	FHRB-2270	FHFA-2270			
	22.8	FHSA-2280	FHSM-2280	FHSB-2280	FHRA-2280	FHRB-2280	FHFA-2280			
	22.9	FHSA-2290	FHSM-2290	FHSB-2290	FHRA-2290	FHRB-2290	FHFA-2290			
23.0-23.9	23.0	FHSA-2300	FHSM-2300	FHSB-2300	FHRA-2300	FHRB-2300	FHFA-2300	13.3	9.3	FD230239...
	23.1	FHSA-2310	FHSM-2310	FHSB-2310	FHRA-2310	FHRB-2310	FHFA-2310			
	23.2	FHSA-2320	FHSM-2320	FHSB-2320	FHRA-2320	FHRB-2320	FHFA-2320			
	23.3	FHSA-2330	FHSM-2330	FHSB-2330	FHRA-2330	FHRB-2330	FHFA-2330			
	23.4	FHSA-2340	FHSM-2340	FHSB-2340	FHRA-2340	FHRB-2340	FHFA-2340			
	23.5	FHSA-2350	FHSM-2350	FHSB-2350	FHRA-2350	FHRB-2350	FHFA-2350			
	23.6	FHSA-2360	FHSM-2360	FHSB-2360	FHRA-2360	FHRB-2360	FHFA-2360			
	23.7	FHSA-2370	FHSM-2370	FHSB-2370	FHRA-2370	FHRB-2370	FHFA-2370			
	23.8	FHSA-2380	FHSM-2380	FHSB-2380	FHRA-2380	FHRB-2380	FHFA-2380			
	23.9	FHSA-2390	FHSM-2390	FHSB-2390	FHRA-2390	FHRB-2390	FHFA-2390			
24.0-24.9	24.0	FHSA-2400	FHSM-2400	FHSB-2400	FHRA-2400	FHRB-2400	FHFA-2400	13.9	9.7	FD240249...
	24.1	FHSA-2410	FHSM-2410	FHSB-2410	FHRA-2410	FHRB-2410	FHFA-2410			
	24.2	FHSA-2420	FHSM-2420	FHSB-2420	FHRA-2420	FHRB-2420	FHFA-2420			
	24.3	FHSA-2430	FHSM-2430	FHSB-2430	FHRA-2430	FHRB-2430	FHFA-2430			
	24.4	FHSA-2440	FHSM-2440	FHSB-2440	FHRA-2440	FHRB-2440	FHFA-2440			
	24.5	FHSA-2450	FHSM-2450	FHSB-2450	FHRA-2450	FHRB-2450	FHFA-2450			
	24.6	FHSA-2460	FHSM-2460	FHSB-2460	FHRA-2460	FHRB-2460	FHFA-2460			
	24.7	FHSA-2470	FHSM-2470	FHSB-2470	FHRA-2470	FHRB-2470	FHFA-2470			
	24.8	FHSA-2480	FHSM-2480	FHSB-2480	FHRA-2480	FHRB-2480	FHFA-2480			
	24.9	FHSA-2490	FHSM-2490	FHSB-2490	FHRA-2490	FHRB-2490	FHFA-2490			
25.0-26.0	25.0	FHSA-2500	FHSM-2500	FHSB-2500	FHRA-2500	FHRB-2500	FHFA-2500	14.5	10.1	FD250260...
	25.1	FHSA-2510	FHSM-2510	FHSB-2510	FHRA-2510	FHRB-2510	FHFA-2510			
	25.2	FHSA-2520	FHSM-2520	FHSB-2520	FHRA-2520	FHRB-2520	FHFA-2520			
	25.3	FHSA-2530	FHSM-2530	FHSB-2530	FHRA-2530	FHRB-2530	FHFA-2530			
	25.4	FHSA-2540	FHSM-2540	FHSB-2540	FHRA-2540	FHRB-2540	FHFA-2540			
	25.5	FHSA-2550	FHSM-2550	FHSB-2550	FHRA-2550	FHRB-2550	FHFA-2550			
	25.6	FHSA-2560	FHSM-2560	FHSB-2560	FHRA-2560	FHRB-2560	FHFA-2560			
	25.7	FHSA-2570	FHSM-2570	FHSB-2570	FHRA-2570	FHRB-2570	FHFA-2570			
	25.8	FHSA-2580	FHSM-2580	FHSB-2580	FHRA-2580	FHRB-2580	FHFA-2580			
	25.9	FHSA-2590	FHSM-2590	FHSB-2590	FHRA-2590	FHRB-2590	FHFA-2590			
26.0	FHSA-2600	FHSM-2600	FHSB-2600	FHRA-2600	FHRB-2600	FHFA-2600				

РЕКОМЕНДУЕМЫЕ РЕЖИМЫ РЕЗАНИЯ

ISO	Материалы	Состояние	Предел прочности (Н/мм ²)	Твердость	Скорость резания V _c (м/мин)	Подача (мм/об) и диаметр сверла						
						<10	10-11.9	12-13.9	14-15.9	16-19.9	20-25.9	
P	Нелегированная сталь, литье, легкообрабатываемая сталь	<0.25%С	Отожженные	420	125	80-140	0.12-0.22	0.15-0.28	0.18-0.30	0.20-0.35	0.25-0.45	0.25-0.45
		>=0.25%С	Отожженные	650	190	80-130	0.12-0.22	0.15-0.28	0.18-0.30	0.20-0.35	0.25-0.45	0.25-0.45
		<0.55%С	Закалённые и отпущенные	850	250	80-120	0.12-0.22	0.15-0.28	0.18-0.30	0.20-0.35	0.25-0.45	0.25-0.45
		>=0.55%С	Отожженные	750	220	70-110	0.12-0.22	0.15-0.28	0.18-0.30	0.20-0.35	0.25-0.45	0.25-0.45
			Закалённые и отпущенные	1000	300	50-90	0.12-0.22	0.15-0.28	0.18-0.30	0.20-0.35	0.25-0.45	0.25-0.45
	Низколегированная сталь и литье (менее 5% легирующих добавок)	Закалённые и отпущенные	Отожженные	600	200	70-120	0.12-0.25	0.14-0.28	0.16-0.32	0.18-0.35	0.23-0.40	0.25-0.45
				930	275	70-110	0.12-0.25	0.14-0.28	0.16-0.32	0.18-0.35	0.23-0.40	0.25-0.45
				1000	300	50-90	0.12-0.25	0.14-0.28	0.16-0.32	0.18-0.35	0.23-0.40	0.25-0.45
				1200	350	40-70	0.12-0.25	0.14-0.28	0.16-0.32	0.18-0.35	0.23-0.40	0.25-0.45
	Высоколегированная сталь, литье и инструментальная сталь	Закалённые и отпущенные	Отожженные	680	200	50-90	0.12-0.20	0.12-0.22	0.15-0.25	0.18-0.28	0.20-0.30	0.22-0.33
			1100	325	40-80	0.12-0.20	0.12-0.22	0.15-0.25	0.18-0.28	0.20-0.30	0.22-0.33	
M	Нержавеющая сталь и литье	Ферритные/Мартенситные	680	200	40-70	0.10-0.15	0.12-0.18	0.14-0.20	0.16-0.24	0.16-0.26	0.18-0.30	
		Мартенситные	820	240	40-70	0.10-0.15	0.12-0.18	0.14-0.20	0.16-0.24	0.16-0.26	0.18-0.30	
		Аустенитные	600	180	30-70	0.10-0.15	0.12-0.18	0.14-0.20	0.16-0.24	0.16-0.26	0.18-0.30	
K	Серый чугун (GG)	Ферритный		160	90-160	0.15-0.30	0.20-0.35	0.25-0.40	0.30-0.45	0.35-0.55	0.35-0.60	
		Перлитный		250	80-140	0.15-0.30	0.20-0.35	0.25-0.40	0.30-0.45	0.35-0.55	0.35-0.60	
	Чугун с шаровидным графитом (GGG)	Ферритный		180	90-180	0.15-0.30	0.20-0.35	0.25-0.40	0.30-0.45	0.35-0.55	0.35-0.60	
		Перлитный		260	80-140	0.15-0.30	0.20-0.35	0.25-0.40	0.30-0.45	0.35-0.55	0.35-0.60	
	Ковкий чугун	Ферритный		130	90-160	0.15-0.30	0.20-0.35	0.25-0.40	0.30-0.45	0.35-0.55	0.35-0.60	
		Перлитный		230	80-140	0.15-0.30	0.20-0.35	0.25-0.40	0.30-0.45	0.35-0.55	0.35-0.60	
N	Деформируемые алюминиевые сплавы	Неструктурированные		60	90-220	0.20-0.35	0.25-0.40	0.30-0.45	0.35-0.50	0.40-0.60	0.45-0.70	
		Структурированные		100	90-220	0.20-0.35	0.25-0.40	0.30-0.45	0.35-0.50	0.40-0.60	0.45-0.70	
	Алюминий - литье, легированный сплав	<=12% Si	Неструктурированные		75	90-220	0.20-0.35	0.25-0.40	0.30-0.45	0.35-0.50	0.40-0.60	0.45-0.70
			Структурированные		90	90-220	0.20-0.35	0.25-0.40	0.30-0.45	0.35-0.50	0.40-0.60	0.45-0.70
		>12% Si	Жаропрочные сплавы		130	80-160	0.20-0.35	0.25-0.40	0.30-0.45	0.35-0.50	0.40-0.60	0.45-0.70
	Сплавы меди	>1% Pb	Легкообрабатываемые		110	90-220	0.20-0.35	0.25-0.40	0.30-0.45	0.35-0.50	0.40-0.60	0.45-0.70
			Латунь		90	90-220	0.20-0.35	0.25-0.40	0.30-0.45	0.35-0.50	0.40-0.60	0.45-0.70
			Электролитная медь		100	90-220	0.20-0.35	0.25-0.40	0.30-0.45	0.35-0.50	0.40-0.60	0.45-0.70
S	Жаропрочные сплавы	На основе железа	Отожженные		200	30-60	0.06-0.11	0.08-0.13	0.10-0.15	0.12-0.18	0.12-0.20	0.14-0.22
			Структурированные		280	20-50	0.06-0.11	0.08-0.13	0.10-0.15	0.12-0.18	0.12-0.20	0.14-0.22
		На основе никеля или кобальта	Отожженные		250	20-50	0.06-0.11	0.08-0.13	0.10-0.15	0.12-0.18	0.12-0.20	0.14-0.22
			Структурированные		350	20-50	0.06-0.11	0.08-0.13	0.10-0.15	0.12-0.18	0.12-0.20	0.14-0.22
	Титановые сплавы			Rm 400		20-50	0.06-0.12	0.08-0.15	0.10-0.18	0.12-0.20	0.14-0.22	0.16-0.25
		Альфа и бета сплавы структурированные		Rm 1050		20-50	0.06-0.12	0.08-0.15	0.10-0.18	0.12-0.20	0.14-0.22	0.16-0.25
H	Закаленная сталь	Закалка		55 HRC	20-50	0.06-0.12	0.08-0.15	0.10-0.18	0.12-0.20	0.14-0.22	0.16-0.25	
				60 HRC	20-50	0.06-0.12	0.08-0.15	0.10-0.18	0.12-0.20	0.14-0.22	0.16-0.25	

РЕКОМЕНДОВАННЫЕ ЗНАЧЕНИЯ ПАРАМЕТРОВ РЕЗАНИЯ, ПРЕДСТАВЛЕННЫЕ В ТАБЛИЦЕ, ЯВЛЯЮТСЯ ОРИЕНТИРОВОЧНЫМИ И ДОЛЖНЫ ПРИМЕНЯТЬСЯ И КОРРЕКТИРОВАТЬСЯ В ЗАВИСИМОСТИ ОТ КОНКРЕТНЫХ УСЛОВИЙ СВЕРЛЕНИЯ.



5.3. СВЁРЛА СО СМЕННЫМИ ПЛАСТИНАМИ

Представляем Вам новую серию свёрл торговой марки «ИЗ ВОСХОД»

Данная серия разработана с целью повышения производительности и увеличению срока службы инструмента и обладает рядом неоспоримых преимуществ:

1. Один тип пластин в качестве центральной и периферийной, что снижает логистические издержки.
2. Специальная геометрия стружководводящих канавок улучшает отвод стружки.
3. Повышенная жесткость корпуса и увеличенный срок службы.
4. Высокая твердость корпуса, специальная обработка поверхности увеличивают устойчивость к нагрузкам и сопротивлению коррозии.

Стандартная линейка диаметров от 14 до 50.8 мм.

Исполняются в следующих вариантах глубин сверления 2D, 3D, 4D и 5D.

ПРОДУКЦИЯ СОВМЕСТИМА С ПРОДУКЦИЕЙ ТОРГОВОЙ МАРКИ TaeguTec



ПЛАСТИНЫ

Исполнение с 4-мя режущими кромками, благодаря грамотной конструкции позволяют реально использовать каждую из 4-х кромок.

Волнообразная режущая кромка существенно повышает стабильность процесса резания и стружкообразования.

Способствует более жесткому центрированию сверла и значительно снижает силу резания.

ПЛАСТИНЫ

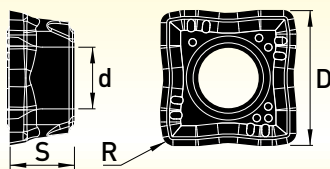
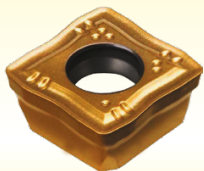

P	★	★	★	
M	★	★		★
K		☆	★	
N				
S				★
H				

Сплавы

УРП	Артикул	D мм	S мм	R мм	d мм	SU32	VM25	VPK25M	ZMS15
05	SD130MT-050204	4.9	2.38	0.4	2.25	●	◎	◎	◎
06	SD130MT-060204	5.7	2.38	0.4	2.60	●	◎	◎	◎
07	SD130MT-070306	6.8	2.80	0.6	2.60	●	◎	◎	◎
08	SD130MT-08T306	7.9	3.97	0.6	2.85	●	◎	◎	◎
09	SD130MT-09T308	9.2	3.97	0.8	3.80	●	◎	◎	◎
11	SD130MT-11T308	11.0	3.97	0.8	3.80	●	◎	◎	◎
13	SD130MT-130408	12.8	4.40	0.8	4.40	●	◎	◎	
15	SD130MT-150510	15.0	4.80	1.0	5.40	●			

СВЁРЛА СО СМЕННЫМИ ПЛАСТИНАМИ. Хвостовик ISO 9766

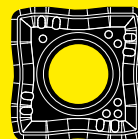
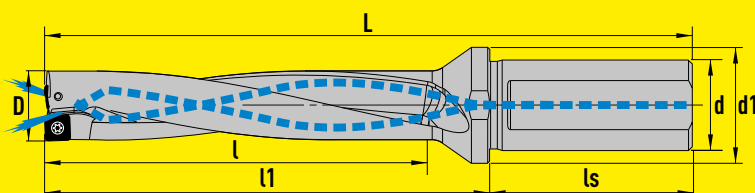

Ø мм	Артикул	Глубина сверления	Статус	l мм	l1 мм	ls мм	L мм	d1 мм	d h6 мм	Винт	Ключ	Применяемая пластина
14.0	SD14002B20S05S05	2D	⊙	28.0	46	50	96	25	20	SDS2049	IP6	SD130MT-050204
	SD14003B20S05S05	3D	⊙	42.0	60	50	110	25	20			
	SD14004B20S05S05	4D	⊙	56.0	74	50	124	25	20			
	SD14005B20S05S05	5D	⊙	70.0	88	50	138	25	20			
14.5	SD14502B20S05S05	2D	⊙	30.0	49	50	99	25	20			
	SD14503B20S05S05	3D	⊙	45.0	64	50	114	25	20			
	SD14504B20S05S05	4D	⊙	60.0	79	22	129	21	20			
	SD14505B20S05S05	5D	⊙	75.0	94	50	144	25	20			
15.0	SD15002B20S05S05	2D	⊙	30.0	49	50	99	25	20			
	SD15003B20S05S05	3D	⊙	45.0	64	50	114	25	20			
	SD15004B20S05S05	4D	⊙	60.0	79	22	129	21	20			
	SD15005B20S05S05	5D	⊙	75.0	94	50	144	25	20			
15.5	SD15502B20S05S05	2D	⊙	32.0	52	50	102	25	20			
	SD15503B20S05S05	3D	⊙	48.0	68	50	118	25	20			
	SD15504B20S05S05	4D	⊙	64.0	84	50	134	25	20			
	SD15505B20S05S05	5D	⊙	80.0	100	50	150	25	20			
16.0	SD16002B20S05S05	2D	⊙	32.0	52	50	102	25	20			
	SD16003B20S05S05	3D	⊙	48.0	68	50	118	25	20			
	SD16004B20S05S05	4D	⊙	64.0	84	50	134	25	20			
	SD16005B20S05S05	5D	⊙	80.0	100	50	150	25	20			
16.5	SD16502B25S06S06	2D	⊙	34.0	54	56	110	32	25	SDS2252	IP7	SD130MT-060204
	SD16503B25S06S06	3D	⊙	51.0	71	56	127	32	25			
	SD16504B25S06S06	4D	⊙	68.0	88	56	144	32	25			
	SD16505B25S06S06	5D	⊙	85.0	105	56	161	32	25			
16.7	SD16703B25S06S06	3D	○	50.1	71	56	127	32	25			
17.0	SD17002B25S06S06	2D	⊙	34.0	54	56	110	32	25			
	SD17003B25S06S06	3D	⊙	51.0	71	56	131	32	25			
	SD17004B25S06S06	4D	⊙	68.0	88	56	144	32	25			
	SD17005B25S06S06	5D	⊙	85.0	105	56	161	32	25			
17.5	SD17502B25S06S06	2D	⊙	36.0	57	56	113	32	25			
	SD17503B25S06S06	3D	⊙	54.0	75	56	131	32	25			
	SD17504B25S06S06	4D	⊙	72.0	93	56	149	32	25			
	SD17505B25S06S06	5D	⊙	90.0	111	56	167	32	25			
18.0	SD18002B25S06S06	2D	⊙	36.0	57	56	113	32	25			
	SD18003B25S06S06	3D	⊙	54.0	75	56	134	32	25			
	SD18004B25S06S06	4D	⊙	72.0	93	56	149	32	25			
	SD18005B25S06S06	5D	⊙	90.0	111	56	167	32	25			
18.5	SD18502B25S06S06	2D	⊙	38.0	59	56	115	32	25			
	SD18503B25S06S06	3D	⊙	57.0	78	56	134	32	25			
	SD18504B25S06S06	4D	⊙	76.0	97	56	153	32	25			
	SD18505B25S06S06	5D	⊙	95.0	116	56	172	32	25			
19.0	SD19002B25S06S06	2D	⊙	38.0	59	56	115	32	25			
	SD19003B25S06S06	3D	⊙	57.0	78	56	139	32	25			
	SD19004B25S06S06	4D	⊙	76.0	97	56	153	32	25			
	SD19005B25S06S06	5D	⊙	95.0	116	56	172	32	25			
19.5	SD19502B25S07S07	2D	⊙	40.0	63	56	119	32	25	SDS2252	IP7	SD130MT-070306
	SD19503B25S07S07	3D	⊙	60.0	83	56	139	32	25			
	SD19504B25S07S07	4D	⊙	80.0	103	56	159	32	25			
	SD19505B25S07S07	5D	⊙	100.0	123	56	179	32	25			
20.0	SD20002B25S07S07	2D	⊙	40.0	63	56	119	32	25			
	SD20003B25S07S07	3D	⊙	60.0	83	56	142	32	25			
	SD20004B25S07S07	4D	⊙	80.0	103	56	159	32	25			
	SD20005B25S07S07	5D	⊙	100.0	123	56	179	32	25			

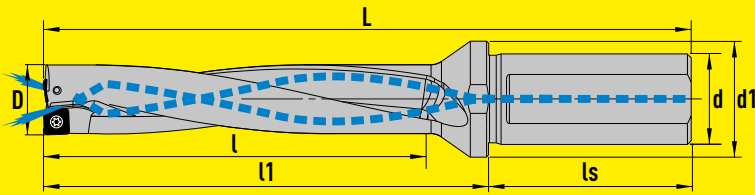

Ø мм	Артикул	Глубина сверления	Статус	l мм	l1 мм	ls мм	L мм	d1 мм	d h6 мм	Винт	Ключ	Применяемая пластина
20.5	SD20502B25S07S07	2D	⊙	42.0	65	56	121	32	25	SDS2252	IP7	SD130MT-070306
	SD20503B25S07S07	3D	⊙	63.0	86	56	142	32	25			
	SD20504B25S07S07	4D	⊙	84.0	107	56	163	32	25			
	SD20505B25S07S07	5D	⊙	105.0	128	56	184	32	25			
21.0	SD21002B25S07S07	2D	⊙	42.0	65	56	121	32	25			
	SD21003B25S07S07	3D	⊙	63.0	86	56	145	32	25			
	SD21004B25S07S07	4D	⊙	84.0	107	56	163	32	25			
	SD21005B25S07S07	5D	⊙	105.0	128	56	184	32	25			
21.5	SD21502B25S07S07	2D	⊙	44.0	67	56	123	32	25			
	SD21503B25S07S07	3D	⊙	66.0	89	56	145	32	25			
	SD21504B25S07S07	4D	⊙	88.0	111	56	167	32	25			
	SD21505B25S07S07	5D	⊙	110.0	133	56	189	32	25			
22.0	SD22002B25S07S07	2D	⊙	44.0	67	56	123	32	25			
	SD22003B25S07S07	3D	⊙	66.0	89	56	145	32	25			
	SD22004B25S07S07	4D	⊙	88.0	111	56	167	32	25			
	SD22005B25S07S07	5D	⊙	110.0	133	56	189	32	25			
22.2	SD22203B25S07S07	3D	○	66.6	89	56	147	32	25			
	SD22205B25S07S07	5D	○	111.0	133	56	189	32	25			
22.5	SD22502B25S08S08	2D	⊙	46.0	68	56	124	32	25			
	SD22503B25S08S08	3D	⊙	69.0	91	56	147	32	25			
	SD22504B25S08S08	4D	⊙	92.0	114	56	170	32	25			
	SD22505B25S08S08	5D	⊙	115.0	137	56	193	32	25			
23.0	SD23002B25S08S08	2D	⊙	46.0	68	56	124	32	25			
	SD23002B32S08S08		○	46.0	68	60	128	40	32			
	SD23003B25S08S08	3D	⊙	69.0	91	56	151	32	25			
	SD23003B32S08S08		○	69.0	91	60	150	40	32			
	SD23004B25S08S08	4D	⊙	92.0	114	56	170	32	25			
	SD23004B32S08S08		○	92.0	114	60	174	40	32			
23.5	SD23005B25S08S08	5D	⊙	115.0	137	56	193	32	25			
	SD23005B32S08S08		○	115.0	137	60	197	40	32			
	SD23502B25S08S08	2D	⊙	48.0	70	56	126	32	25			
	SD23502B32S08S08		○	48.0	70	60	130	40	32			
	SD23503B25S08S08	3D	⊙	72.0	94	56	154	32	25			
	SD23503B32S08S08		○	72.0	94	60	154	40	32			
24.0	SD23504B25S08S08	4D	⊙	96.0	118	56	174	32	25			
	SD23504B32S08S08		○	96.0	118	60	178	40	32			
	SD23505B25S08S08	5D	⊙	120.0	142	56	198	32	25			
	SD23505B32S08S08		○	120.0	142	60	202	40	32			
24.5	SD24002B25S08S08	2D	⊙	48.0	70	56	126	32	25			
	SD24002B32S08S08		○	48.0	70	60	130	40	32			
	SD24003B25S08S08	3D	⊙	72.0	94	56	150	32	25			
	SD24003B32S08S08		○	72.0	94	60	154	40	32			
	SD24004B25S08S08	4D	⊙	96.0	118	56	174	32	25			
	SD24004B32S08S08		○	96.0	118	60	178	40	32			
24.5	SD24005B25S08S08	5D	⊙	120.0	142	56	198	32	25			
	SD24005B32S08S08		○	120.0	142	60	202	40	32			
	SD24502B25S08S08	2D	⊙	50.0	72	56	128	32	25			
	SD24502B32S08S08		○	50.0	72	60	132	40	32			
	SD24503B25S08S08	3D	⊙	75.0	97	56	153	32	25			
	SD24503B32S08S08		○	75.0	97	60	157	40	32			
24.5	SD24504B25S08S08	4D	⊙	100.0	122	56	178	32	25			
	SD24504B32S08S08		○	100.0	122	60	182	40	32			
	SD24505B25S08S08	5D	⊙	125.0	147	56	203	32	25			
	SD24505B32S08S08		○	125.0	147	60	207	40	32			

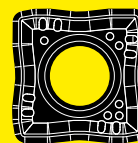
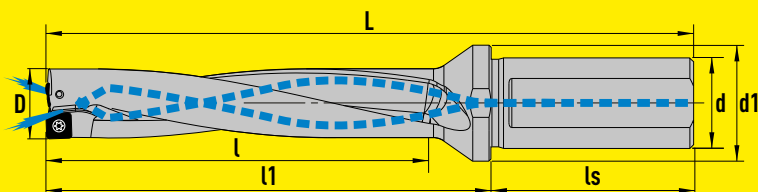

Ø мм	Артикул	Глубина сверления	Статус	l мм	l1 мм	ls мм	L мм	d1 мм	d h6 мм	Винт	Ключ	Применяемая пластина
25.0	SD25002B25S08S08	2D	●	50.0	72	56	128	32	25	SDS2565	IP8	SD130MT-08T306
	SD25002B32S08S08		○	50.0	72	60	132	40	32			
	SD25003B25S08S08	3D	●	75.0	97	56	153	32	25			
	SD25003B32S08S08		○	75.0	97	60	157	40	32			
	SD25004B25S08S08	4D	○	100.0	122	56	178	32	25			
	SD25004B32S08S08		○	100.0	122	60	182	40	32			
	SD25005B25S08S08	5D	●	125.0	147	56	203	32	25			
	SD25005B32S08S08		○	125.0	147	60	207	40	32			
25.4	SD25403B25S08S08	3D	○	76.2	97	56	153	32	25			
	SD25404B25S08S08	4D	○	101.6	122	56	178	32	25			
25.5	SD25502B25S08S08	2D	●	52.0	73	56	129	32	25			
	SD25502B32S08S08		○	52.0	73	60	133	40	32			
	SD25503B25S08S08	3D	●	78.0	99	56	155	32	25			
	SD25503B32S08S08		○	78.0	99	60	159	40	32			
	SD25504B25S08S08	4D	●	104.0	125	56	181	32	25			
	SD25504B32S08S08		○	104.0	125	60	185	40	32			
	SD25505B25S08S08	5D	●	130.0	151	56	207	32	25			
	SD25505B32S08S08		○	130.0	151	60	211	40	32			
26.0	SD26002B25S08S08	2D	●	52.0	73	56	129	32	25			
	SD26002B32S08S08		○	52.0	73	60	133	40	32			
	SD26003B25S08S08	3D	●	78.0	99	56	155	32	25			
	SD26003B32S08S08		○	78.0	99	60	159	32	32			
	SD26004B25S08S08	4D	●	104.0	125	56	181	32	25			
	SD26004B32S08S08		○	104.0	125	60	185	40	32			
	SD26005B25S08S08	5D	●	130.0	151	56	207	32	25			
	SD26005B32S08S08		○	130.0	151	60	211	40	32			
26.5	SD26502B32S09S09	2D	●	54.0	77	60	137	40	32			
	SD26503B25S09S09	3D	●	81.0	104	56	160	40	25			
	SD26503B32S09S09		○	81.0	104	60	164	40	32			
	SD26504B25S09S09	4D	●	108.0	131	56	187	40	25			
	SD26504B32S09S09		○	108.0	131	60	191	40	32			
	SD26505B32S09S09	5D	●	135.0	158	60	218	40	32			
27.0	SD27002B25S09S09	2D	●	54.0	77	56	133	40	25			
	SD27002B32S09S09		○	54.0	77	60	137	40	32			
	SD27003B25S09S09	3D	●	81.0	104	56	160	40	25			
	SD27003B32S09S09		○	81.0	104	60	164	40	32			
	SD27004B25S09S09	4D	●	108.0	131	56	187	40	25			
	SD27004B32S09S09		○	108.0	131	60	191	40	32			
	SD27005B25S09S09	5D	●	135.0	158	56	214	40	25			
	SD27005B32S09S09		○	135.0	158	60	218	40	32			
27.5	SD27502B32S09S09	2D	●	56.0	79	60	139	40	32			
	SD27503B25S09S09	3D	●	84.0	107	56	163	40	25			
	SD27503B32S09S09		○	84.0	107	60	167	40	32			
	SD27504B25S09S09	4D	●	112.0	135	56	191	40	25			
	SD27504B32S09S09		○	112.0	135	60	195	40	32			
	SD27505B32S09S09	5D	●	140.0	163	60	223	40	32			
28.0	SD28002B25S09S09	2D	●	56.0	79	56	135	40	25			
	SD28002B32S09S09		○	56.0	79	60	139	40	32			
	SD28003B25S09S09	3D	●	84.0	107	56	163	40	25			
	SD28003B32S09S09		○	84.0	107	60	167	40	32			
	SD28004B25S09S09	4D	●	112.0	135	56	191	40	25			
	SD28004B32S09S09		○	112.0	135	60	195	40	32			
	SD28005B25S09S09	5D	●	140.0	163	56	219	40	25			
	SD28005B32S09S09		○	140.0	163	60	223	40	32			

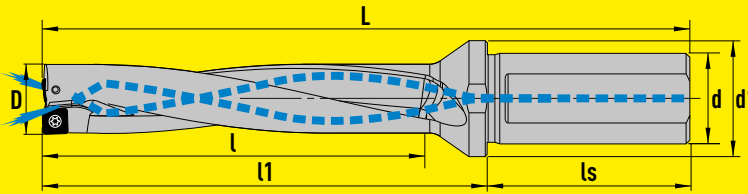

D мм	Артикул	Глубина сверления	Статус	L мм	l1 мм	ls мм	L мм	d1 мм	d h6 мм	Винт	Ключ	Применяемая пластина
28.2	SD28205B32S09S09	5D	○	141.0	163	60	223	40	32	SDS3585	IP10	SD130MT-09T308
28.5	SD28502B32S09S09	2D	⊙	58.0	81	60	141	40	32			
	SD28503B25S09S09	3D	⊙	87.0	110	56	166	40	25			
	SD28503B32S09S09		○	87.0	110	60	170	40	32			
	SD28504B25S09S09	4D	⊙	116.0	139	56	195	40	25			
	SD28504B32S09S09		○	116.0	139	60	199	40	32			
	SD28505B32S09S09	5D	○	145.0	168	60	228	40	32			
28.6	SD28604B32S09S09	4D	○	114.4	139	60	199	40	32			
29.0	SD29002B25S09S09	2D	○	58.0	81	56	137	40	25			
	SD29002B32S09S09		⊙	58.0	81	60	141	40	32			
	SD29003B25S09S09	3D	○	87.0	110	56	166	40	25			
	SD29003B32S09S09		⊙	87.0	110	60	170	40	32			
	SD29004B25S09S09	4D	○	116.0	139	56	195	40	25			
	SD29004B32S09S09		⊙	116.0	139	60	199	40	32			
	SD29005B25S09S09	5D	○	145.0	168	56	224	40	25			
	SD29005B32S09S09		⊙	145.0	168	60	228	40	32			
29.5	SD29502B32S09S09	2D	⊙	60.0	83	60	143	40	32			
	SD29503B32S09S09	3D	⊙	90.0	113	60	173	40	32			
	SD29504B32S09S09	4D	⊙	120.0	143	60	203	40	32			
	SD29505B32S09S09	5D	⊙	150.0	173	60	233	40	32			
30.0	SD30002B32S09S09	2D	⊙	60.0	83	60	143	40	32			
	SD30003B32S09S09	3D	⊙	90.0	113	60	173	40	32			
	SD30004B32S09S09	4D	⊙	120.0	143	60	203	40	32			
	SD30005B32S09S09	5D	⊙	150.0	173	60	233	40	32			
30.5	SD30502B32S09S09	2D	⊙	62.0	85	60	145	40	32			
	SD30503B32S09S09	3D	⊙	93.0	116	60	176	40	32			
	SD30504B32S09S09	4D	⊙	124.0	147	60	207	40	32			
	SD30505B32S09S09	5D	⊙	155.0	178	60	238	40	32			
31.0	SD31002B32S09S09	2D	⊙	62.0	85	60	145	40	32			
	SD31003B32S09S09	3D	⊙	93.0	116	60	176	40	32			
	SD31004B32S09S09	4D	⊙	124.0	147	60	207	40	32			
	SD31005B32S09S09	5D	⊙	155.0	178	60	238	40	32			
31.8	SD31804B32S11S11	4D	○	127.2	151	60	211	40	32	SDS3585	IP10	SD130MT-11T308
32.0	SD32002B32S11S11	2D	⊙	64.0	87	60	147	40	32			
	SD32002B40S11S11		○	64.0	87	70	157	50	40			
	SD32003B32S11S11	3D	⊙	96.0	119	60	179	40	32			
	SD32003B40S11S11		○	96.0	119	70	189	50	40			
	SD32004B32S11S11	4D	⊙	128.0	151	60	211	40	32			
	SD32004B40S11S11		○	128.0	151	70	221	50	40			
	SD32005B32S11S11	5D	⊙	160.0	183	60	243	40	32			
	SD32005B40S11S11		○	160.0	183	70	253	50	40			
33.0	SD33002B32S11S11	2D	⊙	66.0	89	60	149	40	32			
	SD33002B40S11S11		○	66.0	89	70	159	50	40			
	SD33003B32S11S11	3D	⊙	99.0	122	60	182	40	32			
	SD33003B40S11S11		○	99.0	122	70	192	50	40			
	SD33004B32S11S11	4D	⊙	132.0	155	60	215	40	32			
	SD33004B40S11S11		○	132.0	155	70	225	50	40			
	SD33005B32S11S11	5D	⊙	165.0	188	60	248	40	32			
SD33005B40S11S11	○		165.0	188	70	258	50	40				

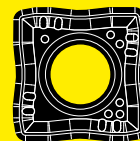
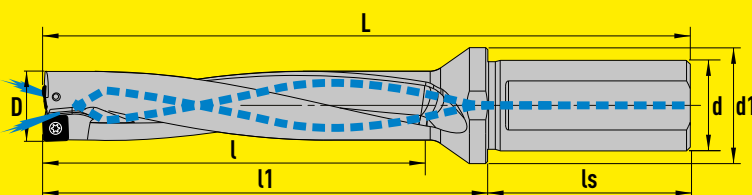

Ø мм	Артикул	Глубина сверления	Статус	l мм	l1 мм	ls мм	L мм	d1 мм	d h6 мм	Винт	Ключ	Применяемая пластина
34.0	SD34002B32S11S11	2D	●	68.0	91	60	151	40	32	SDS3585	IP10	SD130MT-11T308
	SD34002B40S11S11		○	68.0	91	70	161	50	40			
	SD34003B32S11S11	3D	●	102.0	125	60	185	40	32			
	SD34003B40S11S11		○	102.0	125	70	195	50	40			
	SD34004B32S11S11	4D	●	136.0	159	60	219	40	32			
	SD34004B40S11S11		○	136.0	159	70	229	50	40			
	SD34005B32S11S11	5D	●	170.0	193	60	253	40	32			
	SD34005B40S11S11		○	170.0	193	70	263	50	40			
34.9	SD34904B40S11S11	4D	○	139.6	163	70	233	50	40			
35.0	SD35002B32S11S11	2D	●	70.0	93	60	153	40	32			
	SD35002B40S11S11		○	70.0	93	70	163	50	40			
	SD35003B32S11S11	3D	●	105.0	128	60	188	40	32			
	SD35003B40S11S11		○	105.0	128	70	198	50	40			
	SD35004B32S11S11	4D	●	140.0	163	60	223	40	32			
	SD35004B40S11S11		○	140.0	163	70	233	50	40			
	SD35005B32S11S11	5D	●	175.0	198	60	258	40	32			
	SD35005B40S11S11		○	175.0	198	70	268	50	40			
36.0	SD36002B32S11S11	2D	●	72.0	95	60	155	40	32			
	SD36002B40S11S11		○	72.0	95	70	165	50	40			
	SD36003B32S11S11	3D	●	108.0	131	60	191	40	32			
	SD36003B40S11S11		○	108.0	131	70	201	50	40			
	SD36004B32S11S11	4D	●	144.0	167	60	227	40	32			
	SD36004B40S11S11		○	144.0	167	70	237	50	40			
	SD36005B32S11S11	5D	○	180.0	203	60	263	40	32			
	SD36005B40S11S11		○	180.0	203	70	273	50	40			
37.0	SD37002B32S13S13	2D	●	74.0	102	60	162	50	32			
	SD37002B40S13S13		○	74.0	102	70	172	50	40			
	SD37003B32S13S13	3D	●	111.0	139	60	199	50	32			
	SD37003B40S13S13		○	111.0	139	70	209	50	40			
	SD37004B32S13S13	4D	●	148.0	176	60	236	50	32			
	SD37004B40S13S13		○	148.0	176	70	246	50	40			
	SD37005B32S13S13	5D	●	185.0	213	60	273	50	32			
	SD37005B40S13S13		○	185.0	213	70	283	50	40			
37.1	SD37104B40S13S13	4D	○	148.4	176	70	246	50	40			
38.0	SD38002B32S13S13	2D	●	76.0	104	60	164	50	32			
	SD38002B40S13S13		○	76.0	104	70	174	50	40			
	SD38003B32S13S13	3D	●	114.0	142	60	202	50	32			
	SD38003B40S13S13		○	114.0	142	70	212	50	40			
	SD38004B32S13S13	4D	●	152.0	180	60	240	50	32			
	SD38004B40S13S13		○	152.0	180	70	250	50	40			
	SD38005B32S13S13	5D	●	190.0	218	60	278	50	32			
	SD38005B40S13S13		○	190.0	218	70	288	50	40			
38.1	SD38104B40S13S13	4D	○	152.4	180	70	250	50	40			
39.0	SD39002B32S13S13	2D	●	78.0	106	60	166	50	32			
	SD39002B40S13S13		○	78.0	106	70	176	50	40			
	SD39003B32S13S13	3D	●	117.0	145	60	205	50	32			
	SD39003B40S13S13		○	117.0	145	70	215	50	40			
	SD39004B32S13S13	4D	●	156.0	184	60	244	50	32			
	SD39004B40S13S13		○	156.0	184	70	254	50	40			
	SD39005B32S13S13	5D	●	195.0	223	60	283	50	32			
	SD39005B40S13S13		○	195.0	223	70	293	50	40			

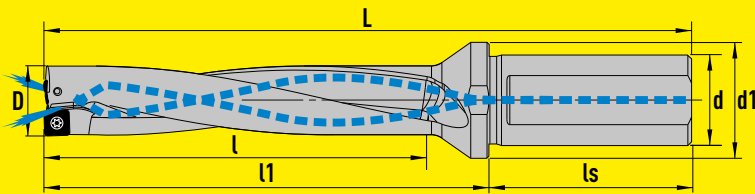

D мм	Артикул	Глубина сверления	Статус	l мм	l1 мм	l2 мм	L мм	d1 мм	d h6 мм	Винт	Ключ	Применяемая пластина
40.0	SD40002B32S13S13	2D	⊙	80.0	108	60	168	50	32	SDS4011	IP15	SD130MT-130408
	SD40002B40S13S13		○	80.0	108	70	178	50	40			
	SD40003B32S13S13	3D	⊙	120.0	148	60	208	50	32			
	SD40003B40S13S13		○	120.0	148	70	218	40	40			
	SD40004B32S13S13	4D	⊙	160.0	188	60	248	50	32			
	SD40004B40S13S13		○	160.0	188	70	258	50	40			
	SD40005B32S13S13	5D	⊙	200.0	228	60	288	50	32			
	SD40005B40S13S13		○	200.0	228	70	298	50	40			
41.0	SD41002B40S13S13	2D	⊙	82.0	110	70	180	50	40			
	SD41003B40S13S13	3D	⊙	123.0	151	70	221	50	40			
	SD41004B40S13S13	4D	⊙	164.0	192	70	262	50	40			
	SD41005B40S13S13	5D	⊙	205.0	233	70	303	50	40			
41.3	SD41304B40S13S13	4D	○	165.2	192	70	262	50	40			
42.0	SD42002B40S13S13	2D	⊙	84.0	112	70	182	50	40			
	SD42003B40S13S13	3D	⊙	126.0	154	70	224	50	40			
	SD42004B40S13S13	4D	⊙	168.0	196	70	266	50	40			
	SD42005B40S13S13	5D	⊙	210.0	238	70	308	50	40			
42.9	SD42904B40S13S13	4D	○	171.6	200	70	270	50	40			
43.0	SD43002B40S13S13	2D	⊙	86.0	114	70	184	50	40			
	SD43003B40S13S13	3D	⊙	129.0	157	70	227	50	40			
	SD43004B40S13S13	4D	⊙	172.0	200	70	270	50	40			
	SD43005B40S13S13	5D	⊙	215.0	243	70	313	50	40			
44.0	SD44002B40S15S15	2D	⊙	88.0	123	70	193	60	40			
	SD44003B40S15S15	3D	⊙	132.0	167	70	237	60	40			
	SD44004B40S15S15	4D	⊙	176.0	211	70	281	50	40			
	SD44005B40S15S15	5D	⊙	220.0	255	70	325	60	40			
44.5	SD44504B40S15S15	4D	○	178.0	215	70	285	60	40			
45.0	SD45002B40S15S15	2D	⊙	90.0	125	70	195	60	40			
	SD45003B40S15S15	3D	⊙	135.0	170	70	240	60	40			
	SD45004B40S15S15	4D	⊙	180.0	215	70	285	60	40			
	SD45005B40S15S15	5D	⊙	225.0	260	70	330	60	40			
46.0	SD46002B40S15S15	2D	⊙	92.0	127	70	197	60	40			
	SD46003B40S15S15	3D	⊙	138.0	173	70	243	60	40			
	SD46004B40S15S15	4D	⊙	184.0	219	70	289	60	40			
	SD46005B40S15S15	5D	⊙	230.0	265	70	335	60	40			
47.0	SD47002B40S15S15	2D	⊙	94.0	129	70	199	60	40			
	SD47003B40S15S15	3D	⊙	141.0	176	70	246	60	40			
	SD47004B40S15S15	4D	⊙	188.0	223	70	293	60	40			
	SD47005B40S15S15	5D	⊙	235.0	270	70	340	60	40			
47.6	SD47604B40S15S15	4D	○	190.4	227	70	297	60	40			
48.0	SD48002B40S15S15	2D	⊙	96.0	131	70	201	60	40			
	SD48003B40S15S15	3D	⊙	144.0	179	70	249	60	40			
	SD48004B40S15S15	4D	⊙	192.0	227	70	297	60	40			
	SD48005B40S15S15	5D	⊙	240.0	275	70	345	60	40			
49.0	SD49002B40S15S15	2D	⊙	98.0	133	70	203	60	40			
	SD49003B40S15S15	3D	⊙	147.0	182	70	252	60	40			
	SD49004B40S15S15	4D	⊙	196.0	231	70	301	60	40			
	SD49005B40S15S15	5D	⊙	245.0	280	70	350	60	40			
50.0	SD50002B40S15S15	2D	⊙	100.0	135	70	205	60	40			
	SD50003B40S15S15	3D	⊙	150.0	185	70	255	60	40			
	SD50004B40S15S15	4D	⊙	200.0	235	70	305	60	40			
	SD50005B40S15S15	5D	⊙	250.0	285	70	355	60	40			
50.8	SD50804B40S15S15	4D	○	203.2	239	70	309	60	40			

РЕКОМЕНДУЕМЫЕ РЕЖИМЫ РЕЗАНИЯ ДЛЯ 2, 3, 4XD

ISO	Материалы	Состояние	Предел прочности (Н/мм ²)	Твердость	Скорость резания V _c (м/мин)	Подача (мм/об) и диаметр сверла								
						14-16	17-19	20-22	23-26	27-31	32-36	37-43	44-50	
P	Нелегированная сталь, литье, легкообрабатываемая сталь	<0.25%С	Отожженные	420	125	220-350	0.04-0.06	0.04-0.06	0.04-0.08	0.04-0.08	0.06-0.10	0.06-0.10	0.08-0.12	0.08-0.12
		>=0.25%С	Отожженные	650	190	180-280	0.06-0.10	0.06-0.10	0.06-0.12	0.06-0.12	0.08-0.14	0.08-0.14	0.08-0.16	0.10-0.16
		<0.55%С	Закалённые и отпущенные	850	250	140-240	0.08-0.12	0.08-0.12	0.08-0.16	0.08-0.16	0.10-0.16	0.10-0.16	0.10-0.18	0.10-0.18
		>=0.55%С	Отожженные	750	220	140-240	0.08-0.12	0.08-0.12	0.08-0.16	0.08-0.16	0.10-0.16	0.10-0.16	0.10-0.18	0.10-0.18
	Низколегированная сталь и литье (менее 5% легирующих добавок)	Закалённые и отпущенные		1000	300	140-240	0.08-0.12	0.08-0.12	0.08-0.16	0.08-0.16	0.10-0.16	0.10-0.16	0.10-0.18	0.10-0.18
			Отожженные	600	200	140-240	0.06-0.16	0.06-0.16	0.08-0.20	0.08-0.20	0.08-0.20	0.10-0.22	0.10-0.22	0.10-0.24
		Закалённые и отпущенные		930	275	100-180	0.06-0.16	0.06-0.16	0.08-0.20	0.08-0.20	0.08-0.20	0.08-0.22	0.10-0.22	0.10-0.22
				1000	300	100-180	0.06-0.16	0.06-0.16	0.08-0.20	0.08-0.20	0.08-0.20	0.08-0.22	0.10-0.22	0.10-0.22
			1200	350	100-180	0.06-0.16	0.06-0.16	0.08-0.20	0.08-0.20	0.08-0.20	0.08-0.22	0.10-0.22	0.10-0.22	
	Высоколегированная сталь, литье и инструментальная сталь	Отожженные		680	200	140-200	0.06-0.12	0.06-0.12	0.08-0.16	0.08-0.16	0.08-0.18	0.08-0.20	0.10-0.20	0.10-0.20
Закалённые и отпущенные			1100	325	100-160	0.06-0.12	0.06-0.12	0.08-0.16	0.08-0.16	0.08-0.18	0.08-0.20	0.10-0.20	0.10-0.20	
M	Нержавеющая сталь и литье	Ферритные/Мартенситные	680	200	150-250	0.06-0.12	0.06-0.12	0.06-0.16	0.06-0.16	0.08-0.18	0.08-0.20	0.10-0.20	0.10-0.20	
		Мартенситные	820	240	150-250	0.06-0.12	0.06-0.12	0.06-0.16	0.06-0.16	0.08-0.18	0.08-0.20	0.10-0.20	0.10-0.20	
		Аустенитные	600	180	150-250	0.06-0.12	0.06-0.12	0.06-0.16	0.06-0.16	0.08-0.18	0.08-0.20	0.10-0.20	0.10-0.20	
K	Серый чугун (GG)	Ферритный		160	160-260	0.08-0.18	0.08-0.18	0.10-0.20	0.10-0.20	0.10-0.20	0.10-0.20	0.10-0.22	0.10-0.22	
		Перлитный		250	160-260	0.08-0.18	0.08-0.18	0.10-0.20	0.10-0.20	0.10-0.20	0.10-0.20	0.10-0.22	0.10-0.22	
	Чугун с шаровидным графитом (GGG)	Ферритный		180	160-260	0.08-0.18	0.08-0.18	0.10-0.20	0.10-0.20	0.10-0.20	0.10-0.20	0.10-0.22	0.10-0.22	
		Перлитный		260	160-260	0.08-0.18	0.08-0.18	0.10-0.20	0.10-0.20	0.10-0.20	0.10-0.20	0.10-0.22	0.10-0.22	
	Ковкий чугун	Ферритный		130	120-220	0.08-0.14	0.08-0.14	0.10-0.16	0.10-0.16	0.10-0.16	0.10-0.18	0.10-0.18	0.10-0.18	
		Перлитный		230	120-220	0.08-0.14	0.08-0.14	0.10-0.16	0.10-0.16	0.10-0.16	0.10-0.18	0.10-0.18	0.10-0.18	
N	Деформируемые алюминиевые сплавы	Неструктурированные		60	200-350	0.06-0.15	0.06-0.15	0.08-0.16	0.08-0.16	0.08-0.18	0.08-0.18	0.10-0.18	0.10-0.18	
		Структурированные		100	200-350	0.06-0.15	0.06-0.15	0.08-0.16	0.08-0.16	0.08-0.18	0.08-0.18	0.10-0.18	0.10-0.18	
	Алюминий - литье, легированный сплав	<=12% Si	Неструктурированные		75	200-350	0.06-0.15	0.06-0.15	0.08-0.16	0.08-0.16	0.08-0.18	0.08-0.18	0.10-0.18	0.10-0.18
		Структурированные		90	200-350	0.06-0.15	0.06-0.15	0.08-0.16	0.08-0.16	0.08-0.18	0.08-0.18	0.10-0.18	0.10-0.18	
	>12% Si	Жаропрочные сплавы		130	200-350	0.06-0.15	0.06-0.15	0.08-0.16	0.08-0.16	0.08-0.18	0.08-0.18	0.10-0.18	0.10-0.18	
	Сплавы меди	>1% Pb	Легкообрабатываемые		110	150-250	0.06-0.15	0.06-0.15	0.08-0.16	0.08-0.16	0.08-0.16	0.08-0.17	0.10-0.18	0.10-0.18
			Латунь		90	150-250	0.06-0.15	0.06-0.15	0.08-0.16	0.08-0.16	0.08-0.16	0.08-0.17	0.10-0.18	0.10-0.18
			Электролитная медь		100	150-250	0.06-0.15	0.06-0.15	0.08-0.16	0.08-0.16	0.08-0.16	0.08-0.17	0.10-0.18	0.10-0.18
	Неметаллические материалы	Реактопласты, волокниты			150-250	0.06-0.15	0.06-0.15	0.08-0.16	0.08-0.16	0.10-0.17	0.10-0.17	0.10-0.18	0.10-0.18	
		Твердая резина			150-250	0.06-0.15	0.06-0.15	0.08-0.16	0.08-0.16	0.10-0.17	0.10-0.17	0.10-0.18	0.10-0.18	
S	Жаропрочные сплавы	На основе железа	Отожженные		200	30-60	0.05-0.08	0.05-0.08	0.05-0.09	0.05-0.09	0.06-0.10	0.06-0.10	0.06-0.12	0.06-0.12
			Структурированные		280	30-60	0.05-0.08	0.05-0.08	0.05-0.09	0.05-0.09	0.06-0.10	0.06-0.10	0.06-0.12	0.06-0.12
		На основе никеля или кобальта	Отожженные		250	30-60	0.05-0.08	0.05-0.08	0.05-0.09	0.05-0.09	0.06-0.10	0.06-0.10	0.06-0.12	0.06-0.12
			Структурированные		350	30-60	0.05-0.08	0.05-0.08	0.05-0.09	0.05-0.09	0.06-0.10	0.06-0.10	0.06-0.12	0.06-0.12
	Литье			320	30-60	0.05-0.08	0.05-0.08	0.05-0.09	0.05-0.09	0.06-0.10	0.06-0.10	0.06-0.12	0.06-0.12	
Титановые сплавы		Rm 400		50-80	0.06-0.09	0.06-0.09	0.06-0.10	0.06-0.10	0.06-0.10	0.06-0.10	0.06-0.10	0.06-0.10	0.06-0.10	
	Альфа и бета сплавы структурированные	Rm 1050		50-80	0.06-0.09	0.06-0.09	0.06-0.10	0.06-0.10	0.06-0.10	0.06-0.10	0.06-0.10	0.06-0.10	0.06-0.10	
H	Закаленная сталь	Закалка		55 HRC	30-60	0.05-0.09	0.05-0.09	0.05-0.10	0.05-0.10	0.05-0.10	0.05-0.10	0.05-0.10	0.05-0.10	
				60 HRC	30-60	0.05-0.09	0.05-0.09	0.05-0.10	0.05-0.10	0.05-0.10	0.05-0.10	0.05-0.10	0.05-0.10	
	Отбеленный чугун	Литье		400	30-60	0.05-0.09	0.05-0.09	0.05-0.10	0.05-0.10	0.05-0.10	0.05-0.10	0.05-0.10	0.05-0.10	
Чугун с шаровидным графитом	Закалка		55 HRC	30-60	0.05-0.09	0.05-0.09	0.05-0.10	0.05-0.10	0.05-0.10	0.05-0.10	0.05-0.10	0.05-0.10		

РЕКОМЕНДОВАННЫЕ ЗНАЧЕНИЯ ПАРАМЕТРОВ РЕЗАНИЯ, ПРЕДСТАВЛЕННЫЕ В ТАБЛИЦЕ, ЯВЛЯЮТСЯ ОРИЕНТИРОВОЧНЫМИ И ДОЛЖНЫ ПРИМЕНЯТЬСЯ И КОРРЕКТИРОВАТЬСЯ В ЗАВИСИМОСТИ ОТ КОНКРЕТНЫХ УСЛОВИЙ СВЕРЛЕНИЯ.

РЕКОМЕНДУЕМЫЕ РЕЖИМЫ РЕЗАНИЯ ДЛЯ 5XD

ISO	Материалы	Состояние	Предел прочности (Н/мм²)	Твердость	Скорость резания Vc (м/мин)	Подача (мм/об) и диаметр сверла								
						14-16	17-19	20-22	23-26	27-31	32-36	37-43	44-50	
P	Нелегированная сталь, литье, легкообрабатываемая сталь	<0.25%С	Отожженные	420	125	220-350	0.04-0.05	0.04-0.05	0.04-0.05	0.04-0.06	0.06-0.08	0.06-0.08	0.08-0.10	0.08-0.10
		>=0.25%С	Отожженные	650	190	180-280	0.06-0.08	0.06-0.08	0.06-0.10	0.06-0.10	0.08-0.12	0.08-0.12	0.08-0.14	0.10-0.14
		<0.55%С	Закалённые и отпущенные	850	250	140-240	0.06-0.10	0.06-0.10	0.06-0.12	0.06-0.12	0.10-0.15	0.10-0.15	0.10-0.17	0.10-0.17
		>=0.55%С	Отожженные	750	220	140-240	0.06-0.10	0.06-0.10	0.06-0.12	0.06-0.12	0.10-0.15	0.10-0.15	0.10-0.17	0.10-0.17
			Закалённые и отпущенные	1000	300	140-240	0.06-0.10	0.06-0.10	0.06-0.12	0.06-0.12	0.10-0.15	0.10-0.15	0.10-0.17	0.10-0.17
	Низколегированная сталь и литье (менее 5% легирующих добавок)	Отожженные		600	200	140-240	0.06-0.12	0.06-0.12	0.08-0.16	0.08-0.16	0.08-0.18	0.10-0.20	0.10-0.20	0.10-0.22
				930	275	100-180	0.06-0.12	0.06-0.12	0.08-0.16	0.08-0.16	0.08-0.18	0.10-0.20	0.10-0.20	0.10-0.22
			Закалённые и отпущенные	1000	300	100-180	0.06-0.12	0.06-0.12	0.08-0.16	0.08-0.16	0.08-0.18	0.10-0.20	0.10-0.20	0.10-0.22
				1200	350	100-180	0.06-0.12	0.06-0.12	0.08-0.16	0.08-0.16	0.08-0.18	0.10-0.20	0.10-0.20	0.10-0.22
	Высоколегированная сталь, литье и инструментальная сталь	Отожженные		680	200	140-200	0.06-0.10	0.06-0.10	0.08-0.12	0.08-0.12	0.08-0.16	0.08-0.18	0.10-0.18	0.10-0.20
Закалённые и отпущенные			1100	325	100-160	0.06-0.10	0.06-0.10	0.08-0.12	0.08-0.12	0.08-0.16	0.08-0.18	0.10-0.18	0.10-0.20	
M	Нержавеющая сталь и литье	Ферритные/Мартенситные	680	200	150-250	0.06-0.10	0.06-0.10	0.06-0.12	0.06-0.12	0.08-0.16	0.08-0.18	0.10-0.18	0.10-0.20	
		Мартенситные	820	240	150-250	0.06-0.10	0.06-0.10	0.06-0.12	0.06-0.12	0.08-0.16	0.08-0.18	0.10-0.18	0.10-0.20	
		Аустенитные	600	180	150-250	0.06-0.10	0.06-0.10	0.06-0.12	0.06-0.12	0.08-0.16	0.08-0.18	0.10-0.18	0.10-0.20	
K	Серый чугун (GG)	Ферритный		160	160-260	0.08-0.14	0.08-0.14	0.08-0.16	0.08-0.16	0.10-0.18	0.10-0.18	0.10-0.20	0.10-0.20	
		Перлитный		250	160-260	0.08-0.14	0.08-0.14	0.08-0.16	0.08-0.16	0.10-0.18	0.10-0.18	0.10-0.20	0.10-0.20	
	Чугун с шаровидным графитом (GGG)	Ферритный		180	160-260	0.08-0.14	0.08-0.14	0.08-0.16	0.08-0.16	0.10-0.18	0.10-0.18	0.10-0.20	0.10-0.20	
		Перлитный		260	160-260	0.08-0.14	0.08-0.14	0.08-0.16	0.08-0.16	0.10-0.18	0.10-0.18	0.10-0.20	0.10-0.20	
	Ковкий чугун	Ферритный		130	120-220	0.08-0.12	0.08-0.14	0.08-0.16	0.08-0.16	0.10-0.16	0.10-0.16	0.10-0.16	0.10-0.16	
		Перлитный		230	120-220	0.08-0.12	0.08-0.14	0.08-0.16	0.08-0.16	0.10-0.16	0.10-0.16	0.10-0.16	0.10-0.16	
N	Деформируемые алюминиевые сплавы	Неструктурированные		60	200-350	0.06-0.15	0.06-0.15	0.08-0.16	0.08-0.16	0.08-0.16	0.08-0.16	0.10-0.17	0.10-0.17	
		Структурированные		100	200-350	0.06-0.15	0.06-0.15	0.08-0.16	0.08-0.16	0.08-0.16	0.08-0.16	0.10-0.17	0.10-0.17	
	Алюминий - литье, легированный сплав	<=12% Si	Неструктурированные		75	200-350	0.06-0.15	0.06-0.15	0.08-0.16	0.08-0.16	0.08-0.16	0.08-0.16	0.10-0.17	0.10-0.17
			Структурированные		90	200-350	0.06-0.15	0.06-0.15	0.08-0.16	0.08-0.16	0.08-0.16	0.08-0.16	0.10-0.17	0.10-0.17
		>12% Si	Жаропрочные сплавы		130	200-350	0.06-0.15	0.06-0.15	0.08-0.16	0.08-0.16	0.08-0.16	0.08-0.16	0.10-0.17	0.10-0.17
	Сплавы меди	>1% Pb	Легкообрабатываемые		110	150-250	0.06-0.15	0.06-0.15	0.08-0.16	0.08-0.16	0.08-0.15	0.08-0.16	0.10-0.17	0.10-0.17
			Латунь		90	150-250	0.06-0.15	0.06-0.15	0.08-0.16	0.08-0.16	0.08-0.15	0.08-0.16	0.10-0.17	0.10-0.17
			Электролитная медь		100	150-250	0.06-0.15	0.06-0.15	0.08-0.16	0.08-0.16	0.08-0.15	0.08-0.16	0.10-0.17	0.10-0.17
	Неметаллические материалы	Реактопласты, волокниты			150-250	0.06-0.15	0.06-0.15	0.08-0.16	0.08-0.16	0.10-0.16	0.10-0.16	0.10-0.17	0.10-0.17	
		Твердая резина			150-250	0.06-0.15	0.06-0.15	0.08-0.16	0.08-0.16	0.10-0.16	0.10-0.16	0.10-0.17	0.10-0.17	
S	Жаропрочные сплавы	На основе железа	Отожженные		200	30-60	0.05-0.07	0.05-0.08	0.05-0.08	0.05-0.08	0.06-0.09	0.06-0.09	0.06-0.10	0.06-0.10
			Структурированные		280	30-60	0.05-0.07	0.05-0.08	0.05-0.08	0.05-0.08	0.06-0.09	0.06-0.09	0.06-0.10	0.06-0.10
		На основе никеля или кобальта	Отожженные		250	30-60	0.05-0.07	0.05-0.08	0.05-0.08	0.05-0.08	0.06-0.09	0.06-0.09	0.06-0.10	0.06-0.10
			Структурированные		350	30-60	0.05-0.07	0.05-0.08	0.05-0.08	0.05-0.08	0.06-0.09	0.06-0.09	0.06-0.10	0.06-0.10
	Титановые сплавы			Rm 400		50-80	0.05-0.08	0.05-0.08	0.06-0.09	0.06-0.09	0.06-0.10	0.06-0.10	0.06-0.10	0.06-0.10
		Альфа и бета сплавы структурированные		Rm 1050		50-80	0.05-0.08	0.05-0.08	0.06-0.09	0.06-0.09	0.06-0.10	0.06-0.10	0.06-0.10	0.06-0.10
H	Закаленная сталь	Закалка		55 HRC		30-60	0.05-0.08	0.05-0.08	0.05-0.09	0.05-0.09	0.05-0.10	0.05-0.10	0.05-0.10	0.05-0.10
				60 HRC		30-60	0.05-0.08	0.05-0.08	0.05-0.09	0.05-0.09	0.05-0.10	0.05-0.10	0.05-0.10	0.05-0.10
	Отбеленный чугун	Литье		400		30-60	0.05-0.08	0.05-0.08	0.05-0.09	0.05-0.09	0.05-0.10	0.05-0.10	0.05-0.10	
Чугун с шаровидным графитом	Закалка		55 HRC		30-60	0.05-0.08	0.05-0.08	0.05-0.09	0.05-0.09	0.05-0.10	0.05-0.10	0.05-0.10	0.05-0.10	

РЕКОМЕНДОВАННЫЕ ЗНАЧЕНИЯ ПАРАМЕТРОВ РЕЗАНИЯ, ПРЕДСТАВЛЕННЫЕ В ТАБЛИЦЕ, ЯВЛЯЮТСЯ ОРИЕНТИРОВОЧНЫМИ И ДОЛЖНЫ ПРИМЕНЯТЬСЯ И КОРРЕКТИРОВАТЬСЯ В ЗАВИСИМОСТИ ОТ КОНКРЕТНЫХ УСЛОВИЙ СВЕРЛЕНИЯ.

5.4. ПЛАСТИНЫ ДЛЯ СВЁРЛ «Sandvik» 880 серии

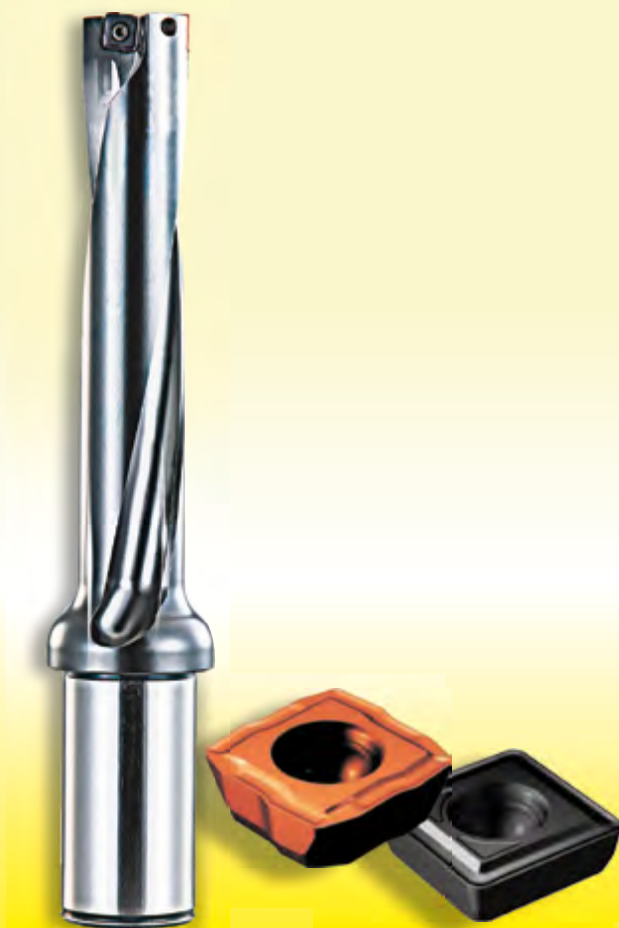

На многих предприятиях России широко применяются сверла со сменными пластинами торговой марки «Sandvik» 880 серии. Зачастую приобретение пластин к этим сверлам является проблемой, да и цена этих пластин, мягко говоря, не гуманна...

Предлагаем замену пластин торговой марки «Sandvik» на пластины торговой марки «ИЗ ВОСХОД», которые по геометрическим параметрам абсолютно идентичны пластинам торговой марки «Sandvik» и совместимы с корпусами их свёрл.

По своим характеристикам пластины торговой марки «ИЗ ВОСХОД» не уступают пластинам «Sandvik», специальная геометрия с PVD-покрытием обеспечивает отличную чистоту поверхности и возможность обработки с высокими подачами.

В случае, если предприятие имеет запас пластин торговой марки «Sandvik» для свёрл 880 серии и ему требуется приобретение новых корпусов свёрл, то мы также предлагаем приобрести у нас корпуса свёрл «ИЗ ВОСХОД», совместимых с пластинами 880 серии торговой марки «Sandvik».

Ассортимент свёрл включает диапазон диаметров от 14 до 52 мм с глубинами сверления 2D, 3D, 4D, 5D. Сверла с диаметром 41–84 мм, а также сверла с хвостовиками HSK, PSC изготавливаются под заказ.

Но если у вас есть потребность и в свёрлах и в пластинах, то лучшим выбором будут свёрла торговой марки «ИЗ ВОСХОД» с двумя одинаковыми пластинами с ломаной режущей кромкой, которые вы найдете в этом каталоге на стр. 90–98.

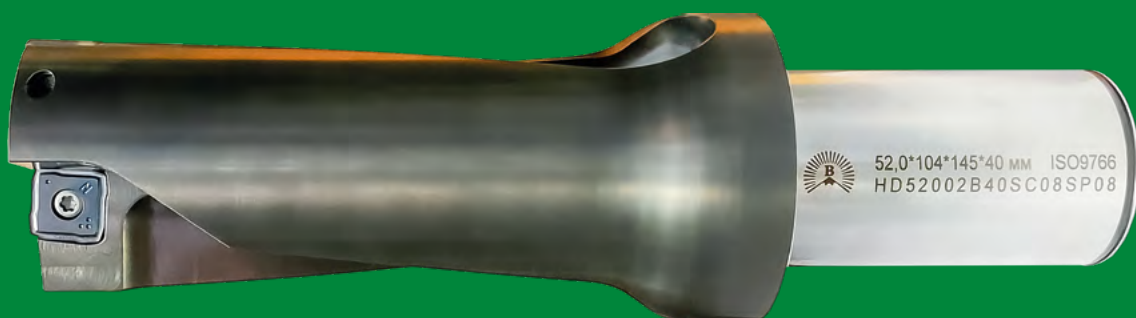

Пластины торговой марки «ИЗ Восход» совместимые с корпусами свёрл серии 880 торговой марки «Sandvik»

РАЗМЕР	ПЛАСТИНЫ (назначение)	АРТИКУЛ «ИЗ ВОСХОД»		АРТИКУЛ «SANDVIK»		ПРИМЕНЯЕМЫЕ КОРПУСА «SANDVIK»
02	ЦЕНТРАЛЬНЫЕ	HDC880-020204-MG	—	880-02 02 04H-C-GM	—	880-D1400÷880-D1600
	ПЕРИФЕРИЙНЫЕ	—	HDP880-020205-MG	—	880-02 02 W05H-P-GM	
03	ЦЕНТРАЛЬНЫЕ	HDC880-030305-MG	—	880-03 03 05H-C-GM	—	880-D1650÷880-D1950
	ПЕРИФЕРИЙНЫЕ	—	HDP880-030305-MG	—	880-03 03 W05H-P-GM	
04	ЦЕНТРАЛЬНЫЕ	HDC880-040305-MG	—	880-04 03 05H-C-GM	—	880-D2000÷880-D2300
	ПЕРИФЕРИЙНЫЕ	—	HDP880-040305-MG	—	880-04 03 W05H-P-GM	
05	ЦЕНТРАЛЬНЫЕ	HDC880-050305-MG	—	880-05 03 05H-C-GM	—	880-D2400÷880-D2900
	ПЕРИФЕРИЙНЫЕ	—	HDP880-050305-MG	—	880-05 03 W05H-P-GM	
06	ЦЕНТРАЛЬНЫЕ	HDC880-060406-MG	—	880-06 04 06H-C-GM	—	880-D3000÷880-D3500
	ПЕРИФЕРИЙНЫЕ	—	HDP880-060406-MG	—	880-06 04 W06H-P-GM	
07	ЦЕНТРАЛЬНЫЕ	HDC880-070406-MG	—	880-07 04 06H-C-GM	—	880-D3600÷880-D4000
	ПЕРИФЕРИЙНЫЕ	—	HDP880-070406-MG	—	880-07 04 W06H-P-GM	
08...09	ЦЕНТРАЛЬНЫЕ	ИЗГОТОВЛЕНИЕ ПОД ЗАКАЗ				
	ПЕРИФЕРИЙНЫЕ					

**Пример заказа: ЦЕНТРАЛЬНАЯ ПЛАСТИНА HDC880-020204-MG
ПЕРИФЕРИЙНАЯ ПЛАСТИНА HDP880-070406-MG**

При необходимости приобретения свёрл для пластин серии 880 торговой марки «Sandvik» просим указать конкретный артикул сверла. Мы предложим вам взаимозаменяемое сверло торговой марки «ИЗ Восход».

ДИАПАЗОН ДИАМЕТРОВ мм	ДИАПАЗОН ГЛУБИН мм	СВЕРЛА «ИЗ ВОСХОД»	СВЕРЛА «SANDVIK»
14÷52	1D÷5D	<p style="text-align: center;">ТИП HD</p> <p style="text-align: center;"></p>	<p style="text-align: center;">ТИП 880</p>





5.5. МНОГОФУНКЦИОНАЛЬНАЯ СИСТЕМА ТОРГОВОЙ МАРКИ «ИЗ ВОСХОД»



МНОГОФУНКЦИОНАЛЬНАЯ СИСТЕМА ТОРГОВОЙ МАРКИ «ИЗ ВОСХОД»

Уникальное решение для осуществления различных операций (сверления, внутреннего растачивания, внешнего точения, подрезки торца) одним инструментом.

Быстрая наладка и короткое время цикла.

Минимальное количество инструментов и низкие затраты на оснастку.

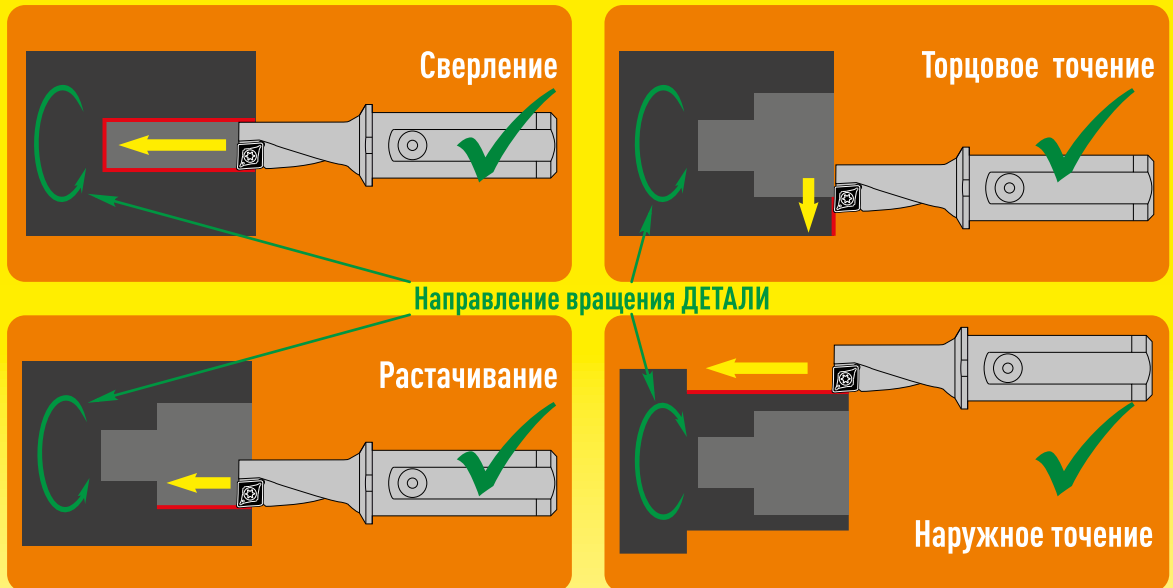

ПРОДУКЦИЯ СОВМЕСТИМА С ПРОДУКЦИЕЙ ТОРГОВОЙ МАРКИ Taegu Tec

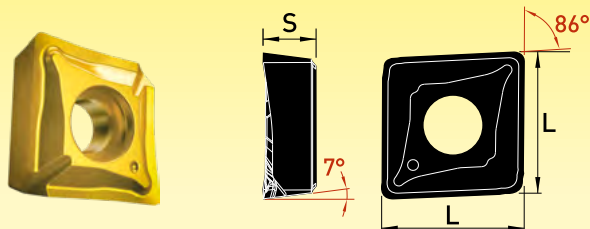

ПЛАСТИНЫ

Артикул	L мм	S мм	R мм	Точение		Сверление	Сплав SU32
				ap мм	f мм/об	f мм/об	
W6CMT-060204	6.4	2.38	0.4	0.3-2.5	0.03-0.20	0.03-0.12	☉
W6CMT-070304	7.5	3.18	0.4	0.4-2.8	0.05-0.22	0.03-0.13	☉
W6CMT-080304	8.4	3.18	0.4	0.4-3.2	0.06-0.25	0.03-0.13	☉
W6CMT-10T304	10.5	3.97	0.4	0.5-3.5	0.06-0.30	0.03-0.13	☉
W6CMT-10T308	10.5	3.97	0.8	0.5-3.5	0.06-0.30	0.03-0.13	☉
W6CMT-130404	13.4	4.76	0.4	0.6-4.3	0.08-0.33	0.03-0.13	☉
W6CMT-130408	13.4	4.76	0.8	0.6-4.3	0.08-0.33	0.03-0.13	☉
W6CMT-170508	17.4	5.56	0.8	0.7-5.3	0.10-0.38	0.03-0.13	☉

ДЕРЖАВКИ МНОГОФУНКЦИОНАЛЬНЫЕ

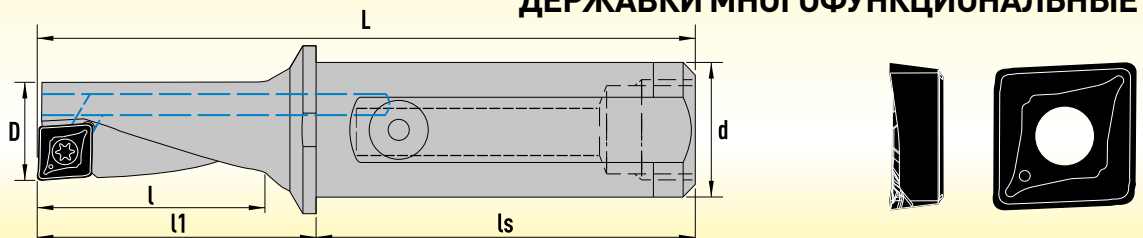

D мм	Артикул	Глубина сверления	Статус	L мм	l1 мм	ls мм	L мм	d мм	D min мм	Винт	Ключ	Применяемая пластина
12	SMF12002B16W06	2.25D	☉	27.0	33.0	45	78.0	16	14.5	SDS2252	IP7	W6CMT-0602...
14	SMF14002B16W07		☉	31.5	38.5	45	83.5	16	16.5	SDS2565	IP8	W6CMT-0703...
16	SMF16002B20W08		☉	36.0	44.0	50	94.0	20	19.0	SDS3085	IP10	W6CMT-0803...
20	SMF20002B25W10		☉	45.0	55.0	56	111.0	25	23.5	SDS3585	IP10	W6CMT-1003...
25	SMF25002B32W13		☉	56.2	69.0	61	130.0	32	29.0	SDS4511	IP15	W6CMT-1304...
32	SMF32002B40W17		☉	72.0	86.0	74	160.0	40	36.5	SDS5012	IP20	W6CMT-1705...

ВАЖНО!!! БУДЬТЕ ПРЕДЕЛЬНО ВНИМАТЕЛЬНЫ ПРИ УСТАНОВКЕ ПЛАСТИН!!!



ОПТИМИЗАЦИЯ ФОРМЫ СТРУЖКИ

Материалы с низким содержанием углерода (низкоуглеродистая сталь/низкоуглеродистая легированная сталь).

Для уменьшения толщины стружки рекомендуется высокоскоростная обработка, которая позволяет избежать многих проблем, вызванных толстой стружкой.

Материалы со средним и высоким содержанием углерода (углеродистая сталь/легированная сталь).

- Слишком тонкая стружка? Увеличьте скорость, если она низкая, или уменьшите подачу.
- Слишком толстая стружка? Уменьшите скорость, если она высокая, или увеличьте подачу.

НАСТРОЙКА

После сверления отверстия на глубину 3–6 мм проверьте наличие заусенца и его размер. Размер заусенца должен быть в пределах 0.15–0.45 мм.

Пожалуйста, отрегулируйте ось Y корпуса инструмента при помощи нового зажимного элемента. Если это невозможно, поверните корпус инструмента на 180°, закрепите его в револьверной голове и снова проверьте заусенец.

Отсутствие заусенца, может стать причиной поломки пластины и вызвать вибрацию при сверлении или точении.

Отклонение диаметра заусенца от рекомендуемого значения, может вызвать перегрузку и вибрацию

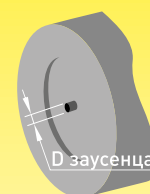

РАДИАЛЬНАЯ РЕГУЛИРОВКА (ВНЕЦЕНТРОВОЕ СВЕРЛЕНИЕ) ДЕРЖАВОК

D мм	Артикул	D min мм	D max мм
12	SMF12002B16W06	11.82	12.60
14	SMF14002B16W07	13.80	14.60
16	SMF16002B20W08	15.76	16.50
20	SMF20002B25W10	19.80	20.60
25	SMF25002B32W13	24.80	25.80
32	SMF32002B40W17	31.80	33.00

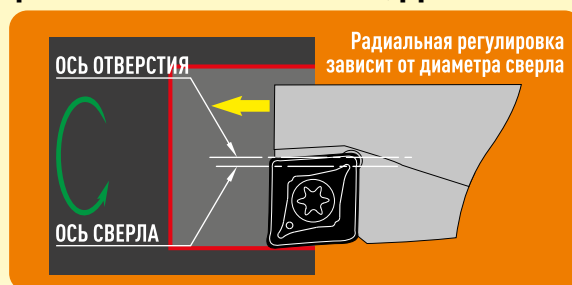

РЕКОМЕНДУЕМЫЕ РЕЖИМЫ РЕЗАНИЯ ДЛЯ 2,25D. СКОРОСТЬ РЕЗАНИЯ (Vc)

ISO	Материалы	Твёрдость (ВН)	Скорость резания Vc (м/мин)	
		ар мм	Сверление	Точение и растачивание
P	Низкоуглеродистая сталь (-0.25% C)	-150	130-240	150-270
	Углеродистая сталь (0.25%<C)	150-250	90-160	100-180
	Низколегированная сталь	-180	120-210	140-230
	Среднелегированная сталь	200-250	70-140	80-160
	Высоколегированная сталь	250-350	50-100	60-120
M	Мартенситная нержавеющая сталь	200	110-180	130-200
	Аустенитная нержавеющая сталь	200	90-160	100-180
K	Серый чугун	180-220	110-180	120-200
	Ковкий чугун	200-240	90-160	100-180
N	Алюминиевый сплав	60-130	100-500	150-600
	Медный сплав	90-100	100-400	100-500

РЕКОМЕНДОВАННЫЕ ЗНАЧЕНИЯ ПАРАМЕТРОВ РЕЗАНИЯ, ПРЕДСТАВЛЕННЫЕ В ТАБЛИЦЕ, ЯВЛЯЮТСЯ ОРИЕНТИРОВОЧНЫМИ И ДОЛЖНЫ ПРИМЕНЯТЬСЯ И КОРРЕКТИРОВАТЬСЯ В ЗАВИСИМОСТИ ОТ КОНКРЕТНЫХ УСЛОВИЙ СВЕРЛЕНИЯ.



25,0*56,2*69,0*25 MIM
ISO 9166
MIM
13
1 3



ФРЕЗЫ СО СМЕННЫМИ ТВЕРДОСПЛАВНЫМИ ПЛАСТИНАМИ



**6.1. ФРЕЗЫ ДЛЯ ОБРАБОТКИ
ПАЗОВ, УСТУПОВ
И ПЛОСКОСТЕЙ**

РАЗДЕЛ 6



ФРЕЗЫ: ТИП SM900500

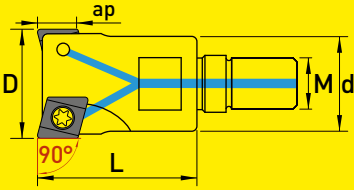

ГОЛОВКИ ФРЕЗЕРНЫЕ С РЕЗЬБОВЫМ ХВОСТОВИКОМ (угол в плане 90°)

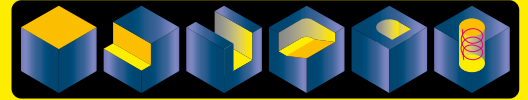

Артикул	D мм	L мм	d мм	M	ap мм	Z	Каналы СОЖ	Пластины	Винт	Ключ
SM900500-016Z02023000M08P06-C	16	23	13	M08	6.0	2	✓	SM0500KT-0602...	SD368	T08
SM900500-016Z02026000M08P06	16	26	13	M08		2	—			
SM900500-016Z02026000M08P06-C	16	26	13	M08		2	✓			
SM900500-017Z02023000M08P06-C	17	23	13	M08		2	✓			
SM900500-017Z02026000M08P06	17	26	13	M08		2	—			
SM900500-017Z02026000M08P06-C	17	26	13	M08		2	✓			
SM900500-020Z02030000M10P06	20	30	18	M10		2	—			
SM900500-020Z02030000M10P06-C	20	30	18	M10		2	✓			
SM900500-020Z02036000M10P06-C	20	36	18	M10		2	✓			
SM900500-020Z03036000M10P06-C	20	36	18	M10		3	✓			
SM900500-021Z03030000M10P06	21	30	18	M10		3	—			
SM900500-021Z03030000M10P06-C	21	30	18	M10		3	✓			
SM900500-021Z03036000M10P06-C	21	36	18	M10		3	✓			
SM900500-025Z03035000M12P06	25	35	21	M12		3	—			
SM900500-025Z03035000M12P06-C	25	35	21	M12		3	✓			
SM900500-025Z03036000M12P06-C	25	36	21	M12		3	✓			
SM900500-025Z04036000M12P06-C	25	36	21	M12		4	✓			
SM900500-026Z04035000M12P06	26	35	21	M12		4	—			
SM900500-025Z03035000M12P06-C	25	35	21	M12		3	✓			
SM900500-026Z04036000M12P06-C	26	36	21	M12		4	✓			
SM900500-032Z04043000M16P06-C	32	43	29	M16		4	✓			
SM900500-032Z05043000M16P06-C	32	43	29	M16		5	✓			
SM900500-033Z05043000M16P06-C	33	43	29	M16		5	✓			
SM900500-035Z05043000M16P06-C	35	43	29	M16		5	✓			
SM900500-040Z05043000M16P06-C	40	43	29	M16		5	✓			
SM900500-040Z06043000M16P06-C	40	43	29	M16		6	✓			

Корпуса фрез с пластинами размером 06 совместимы с пластинами серии 4NKT-0603 торговой марки «TaeguTec».

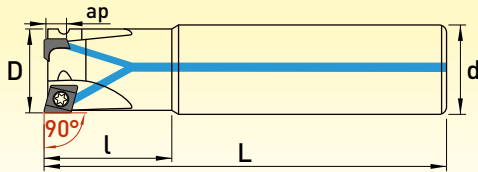

ФРЕЗЫ КОНЦЕВЫЕ С ЦИЛИНДРИЧЕСКИМ ХВОСТОВИКОМ (угол в плане 90°) с мелкогабаритными 2-гранными двусторонними пластинами (4 режущих кромки). Крепление винтом

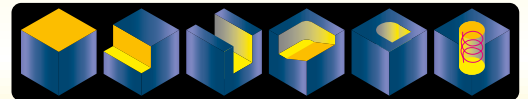

Артикул	D мм	L мм	L мм	d мм	ap мм	Z	Каналы СОЖ	Пластины	Винт	Ключ
SM900500-008Z01017080S08P05	8	17	80	8	4.1	1	—	SM0500KT-0502...	SDT18041	T08
SM900500-010Z01017080S10P05	10	17	80	10		1	—			
SM900500-011Z02000080S10P05	11	—	80	10		2	—			
SM900500-012Z02018080S12P05	12	18	80	12		2	—			
SM900500-013Z03000090S12P05	13	—	90	12		3	—			
SM900500-016Z03020090S16P05	16	20	90	16		3	—			
SM900500-020Z04025160S20P05	20	25	160	20		4	—			

Фрезы с каналами для подвода СОЖ изготавливаются по специальному заказу.

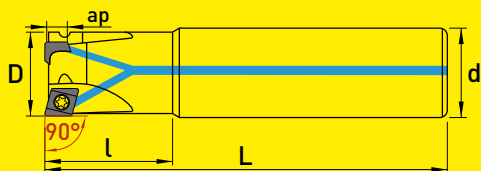

Окончание таблицы

Артикул	D мм	l мм	L мм	d мм	ap мм	Z	Каналы СОЖ	Пластины	Винт	Ключ				
SM900500-016Z02000150S15P06-C	16	—	150	15	6.0	2	✓	SM0500KT-0602...	SD368	T08				
SM900500-016Z02025100S16P06-C	16	25	100	16		2	✓							
SM900500-016Z02025120S16P06-C	16	25	120	16		2	—							
SM900500-016Z02025150S16P06-C	16	25	150	16		2	✓							
SM900500-016Z02040160S16P06	16	40	160	16		2	—							
SM900500-016Z02040200S16P06	16	40	200	16		2	—							
SM900500-017Z02000090S16P06-C	17	—	90	16		2	✓							
SM900500-017Z02000160S16P06	17	—	160	16		2	—							
SM900500-017Z02000200S16P06-C	17	—	200	16		2	✓							
SM900500-018Z02000150S16P06-C	18	—	150	16		2	✓							
SM900500-020Z02000160S19P06-C	20	—	160	19		2	✓							
SM900500-020Z02025110S20P06-C	20	25	110	20		2	✓							
SM900500-020Z02025160S20P06-C	20	25	160	20		2	✓							
SM900500-020Z02040160S20P06	20	40	160	20		2	—							
SM900500-020Z02040200S20P06	20	40	200	20		2	—							
SM900500-020Z03025110S20P06-C	20	25	110	20		3	✓							
SM900500-020Z03040160S20P06	20	40	160	20		3	—							
SM900500-020Z03040200S20P06	20	40	200	20		3	—							
SM900500-021Z02000200S20P06-C	21	—	200	20		2	✓							
SM900500-021Z03000160S20P06	21	—	160	20		3	—							
SM900500-021Z03000200S20P06	21	—	200	20		3	—							
SM900500-025Z03030150S25P06-C	25	30	150	25		3	✓							
SM900500-025Z03030200S25P06-C	25	30	200	25		3	✓							
SM900500-025Z04040160S25P06	25	40	160	25		4	—							
SM900500-025Z04040200S25P06	25	40	200	25		4	—							
SM900500-026Z03000200S25P06-C	26	—	200	25		3	✓							
SM900500-026Z04000160S25P06	26	—	160	25		4	—							
SM900500-026Z04000200S25P06	26	—	200	25		4	—							
SM900500-025Z04030120S25P06-C	25	30	120	25		4	✓							
SM900500-032Z04035150S32P06-C	32	35	150	32		4	✓							
SM900500-032Z04035200S32P06-C	32	35	200	32		4	✓							
SM900500-032Z05035150S32P06-C	32	35	150	32		5	✓							
SM900500-033Z040000200S32P06	33	—	200	32		4	—							
SM900500-033Z04000250S32P06-C	33	—	250	32		4	✓							
SM900500-035Z05000160S32P06	35	—	160	32		5	—							
SM900500-035Z05000200S32P06	35	—	200	32		5	—							
SM900500-040Z05000150S32P06-C	40	—	150	32		5	✓							
SM900500-040Z05000250S32P06-C	40	—	250	32		5	✓							
SM900500-040Z06000150S32P06-C	40	—	150	32		6	✓							
SM900500-016Z02000150S15P07	16	—	150	15		6.6	2				—	SM0500KT-0703...	SDB3070	
SM900500-016Z02025150S16P07	16	25	150	16			2				—			
SM900500-017Z02000090S16P07	17	—	90	16			2				—			
SM900500-017Z02000200S16P07	17	—	200	16	2		—							
SM900500-020Z02000160S19P07	20	—	160	19	2		—							
SM900500-020Z02025160S20P07	20	25	160	20	2		—							
SM900500-021Z02000200S20P07	21	—	200	20	2		—							
SM900500-025Z03030200S25P07	25	30	200	25	3		—							
SM900500-026Z03000200S25P07	26	—	200	25	3		—							
SM900500-032Z04035210S32P07	32	35	210	32	4		—							
SM900500-040Z05000150S32P07	40	—	150	32	5		—							

Корпуса фрез с пластинами размером 06 совместимы с пластинами серии 4NKT-0603 торговой марки «TaeguTec».

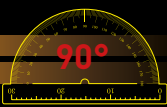

ФРЕЗЫ: ТИП SM900500

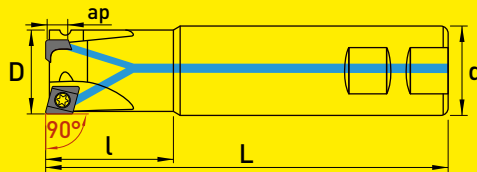

ФРЕЗЫ КОНЦЕВЫЕ С ХВОСТОВИКОМ WELDON (угол в плане 90°) с мелкогабаритными 2-гранными двусторонними пластинами (4 режущих кромки). Крепление винтом

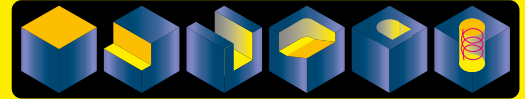

Артикул	Рисунок	D мм	L мм	L мм	d мм	ap мм	Z	Каналы СОЖ	Пластины	Винт	Ключ
SM900500-020Z04025105W20P05	1	20	25	105	20	4.1	4	—	SM0500KT-0502...	SDT18041	T08
SM900500-016Z02025090W16P06-C	1	16	25	90	16	6.0	2	✓	06 SM0500KT-0602...	SD368	
SM900500-016Z02025120W16P06-C	1	16	25	120	16		2	✓			
SM900500-016Z02025160W16P06	1	16	25	160	16		2	—			
SM900500-018Z02000090W16P06-C	1	18	—	90	16		2	✓			
SM900500-020Z02025090W20P06-C	1	20	25	90	20		2	✓			
SM900500-020Z03000120W16P06-C	1	20	—	120	16		3	✓			
SM900500-020Z03000160W16P06	1	20	—	160	16		3	—			
SM900500-020Z03025090W20P06-C	1	20	25	90	20		3	✓			
SM900500-020Z03025160W20P06	1	20	25	160	20		3	—			
SM900500-025Z03030100W25P06-C	1	25	30	100	25		3	✓			
SM900500-025Z04030100W25P06-C	1	25	30	100	25		4	✓			
SM900500-032Z04035110W32P06-C	1	32	35	110	32		4	✓			
SM900500-032Z05035110W32P06-C	1	32	35	110	32		5	✓			
SM900500-040Z05000110W32P06-C	1	40	—	110	32		5	✓			
SM900500-040Z06000110W32P06-C	1	40	—	110	32	6	✓				
SM900500-016Z02025090W16P07	1	16	25	90	16	6.6	2	—	07 SM0500KT-0703...	SDB3070	
SM900500-020Z02025090W20P07	1	20	25	90	20		2	—			
SM900500-025Z03030100W25P07	1	25	30	100	25		3	—			
SM900500-032Z04035110W32P07	1	32	35	110	32		4	—			
SM900500-040Z05000110W32P07	1	40	—	110	32		5	—			

Корпуса фрез с пластинами размером 06 совместимы с пластинами серии 4NKT-0603 торговой марки «ТаегиТес».



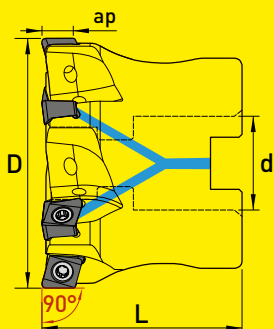

ФРЕЗЫ ТОРЦОВЫЕ НАСАДНЫЕ
(угол в плане 90°)



Артикул	D мм	L мм	d мм	ap мм	Z	Каналы СОЖ	Пластины	Винт	Ключ
SM900500-032Z04032000D16P06-C	32	32	16	6.0	4	✓	SM0500KT-0602...	SD368	T08
SM900500-032Z05032000D16P06-C	32	32	16		5	✓			
SM900500-040Z05040000D16P06-C	40	40	16		5	✓			
SM900500-040Z06040000D16P06-C	40	40	16		6	✓			
SM900500-050Z06040000D22P06-C	50	40	22		6	✓			
SM900500-050Z07040000D22P06-C	50	40	22		7	✓			
SM900500-050Z08050000D22P06	50	50	22		8	—			
SM900500-063Z06040000D22P06	63	40	22		6	—			
SM900500-063Z07040000D22P06-C	63	40	22		7	✓			
SM900500-063Z08040000D22P06-C	63	40	22		8	✓			
SM900500-080Z08050000D27P06	80	50	27		8	—			
SM900500-100Z10050000D32P06	100	50	32		10	—			

Корпуса фрез с пластинами размером 06 совместимы с пластинами серии 4NKT-0603 торговой марки «TaeguTec».

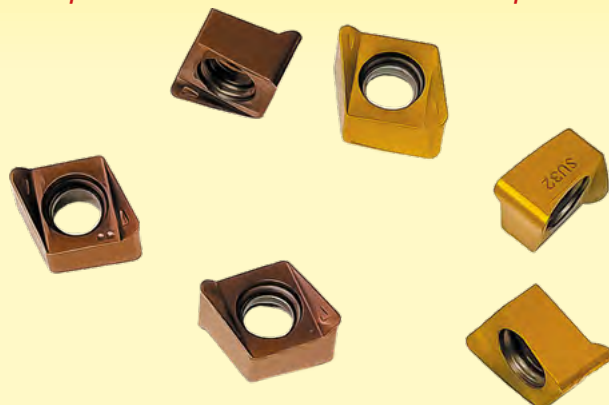

ПЛАСТИНЫ ДЛЯ ФРЕЗ: ТИП SM900500

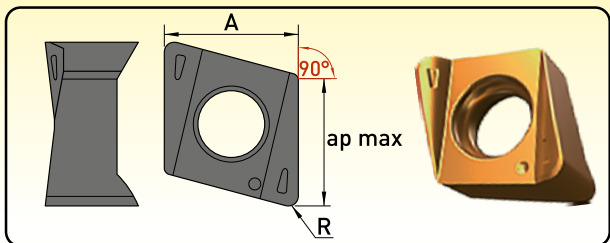

	P	M	K	N	S	H
★	★	★	★	★	★	★
★	★	★	★	★	★	★
☆	★	★	★	★	★	★
☆	★	★	★	★	★	★
☆	★	★	★	★	★	★
☆	★	★	★	★	★	★

С П Л А В Ы								
с покрытием						без покрытия		кермет
СУ32	VPK25M	VM25	VVU25	FPH10	FPM25	FN10	FC15	

УРП	Артикул	A мм	ap max мм	R мм	fz мм/зуб	SU32	VPK25M	VM25	VVU25	FPH10	FPM25	FN10	FC15
5	SM0500KT-050208R-M	4.5	4.1	0.8	0.06-0.12	●							
	SM0500KT-060308R-M						●	●	●	●			●
6	SM0500KT-060308R-LM	6.6	6.0		0.07-0.15								
	SM0500GT-060308R-AL											●	
7	SM0500KT-070308R-M	7.0	6.6		0.08-0.16	●							
	SM0500KT-070308R-LM					●							
9	SM0500KT-090408R-M	8.6	7.0				●	●	●				
11	SM0500KT-110608R-M	10.7	10.0					●	●	●			

Пластины с размерами 06, 09, 11 полностью взаимозаменяемы с пластинами серии 4NKT торговой марки «TaeguTec».

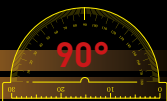

ФРЕЗЫ: ТИП SM900100

ГОЛОВКИ ФРЕЗЕРНЫЕ С РЕЗЬБОВЫМ ХВОСТОВИКОМ (угол в плане 90°)

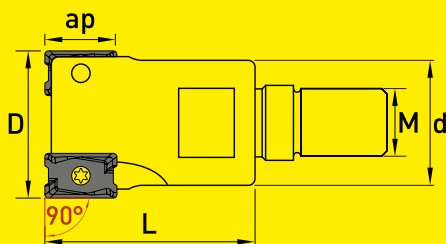
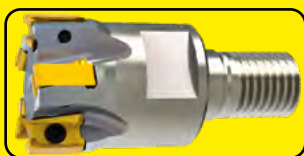

Артикул	D мм	L мм	d мм	ap мм	M	Z	Пластины	Винт	Ключ
SM900100-020Z02028000M10P12	20	28	18	11.5	M10	2	12 SM0100KU-12.../ SM0100HU-12...	SDC3080	T10
SM900100-025Z03040000M12P12	25	40	21	11.5	M12	3			
SM900100-032Z04040000M16P12	32	40	29	11.5	M16	4			
SM900100-032Z05040000M16P12	32	40	29	11.5	M16	5			
SM900100-025Z02032000M12P17	25	32	21	16.5	M12	2	17 SM0100KU-17.../ SM0100HU-17...	SD4010	T15
SM900100-032Z03040000M16P17	32	40	29	16.5	M16	3			
SM900100-032Z04040000M16P17	32	40	29	16.5	M16	4			
SM900100-035Z04040000M16P17	35	40	29	16.5	M16	4			
SM900100-040Z05040000M16P17	40	40	29	16.5	M16	5			
							SDC4013		

Фрезы с каналами для подвода СОЖ изготавливаются по специальному заказу.

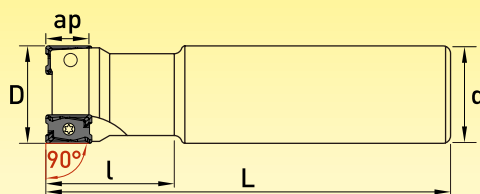
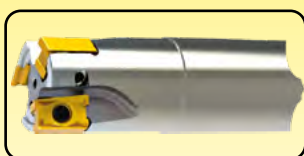

ФРЕЗЫ КОНЦЕВЫЕ С ЦИЛИНДРИЧЕСКИМ ХВОСТОВИКОМ (угол в плане 90°)



Артикул	D мм	L мм	L мм	d мм	ap мм	Z	Пластины	Винт	Ключ			
SM900100-020Z02028150S20P12	20	28	150	20	11.5	2	12 SM0100KU-12.../ SM0100HU-12...	SDC3080	T10			
SM900100-020Z03028090S20P12	20	28	90	20	11.5	3						
SM900100-020Z03028150S20P12	20	28	150	20	11.5	3						
SM900100-025Z03043170S25P12	25	43	170	25	11.5	3						
SM900100-025Z04043100S25P12	25	43	100	25	11.5	4						
SM900100-025Z04043170S25P12	25	43	170	25	11.5	4						
SM900100-032Z04049200S32P12	32	49	200	32	11.5	4						
SM900100-032Z05049110S32P12	32	49	110	32	11.5	5						
SM900100-032Z05049200S32P12	32	49	200	32	11.5	5						
SM900100-040Z05049200S32P12	40	49	200	32	11.5	5						
SM900100-025Z02043100S25P17	25	43	100	25	16.5	2	17 SM0100KU-17.../ SM0100HU-17...	SD4010	T15			
SM900100-025Z02043170S25P17	25	43	170	25	16.5							
SM900100-032Z03049110S32P17	32	49	110	32	16.5	3						
SM900100-032Z03050200S32P17	32	50	200	32	16.5							
SM900100-032Z04049110S32P17	32	49	110	32	16.5	4						
SM900100-032Z04050200S32P17	32	50	200	32	16.5							
SM900100-040Z03050200S32P17	40	50	200	32	16.5	3				SDC4013		
SM900100-040Z04050200S32P17	40	50	200	32	16.5	4						

Фрезы с каналами для подвода СОЖ изготавливаются по специальному заказу.

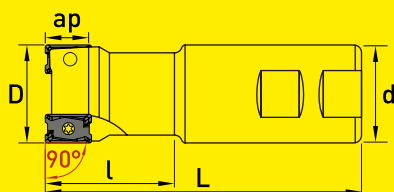

**ФРЕЗЫ КОНЦЕВЫЕ
С ХВОСТОВИКОМ WELDON (угол в плане 90°)**



Артикул	D мм	L мм	L мм	d мм	ap мм	Z	Пластины	Винт	Ключ
SM900100-020Z02028079W20P12	20	28	79	20	11.5	2	SM0100KU-12.../ SM0100HU-12...	SDC3080	T10
SM900100-020Z03028079W20P12						3			
SM900100-025Z03032089W25P12	4								
SM900100-032Z04049110W32P12	5								
SM900100-040Z05049110W32P12	4								
SM900100-025Z02032089W25P17	25	32	89	25	16.5	2	SM0100KU-17.../ SM0100HU-17...	SD4010	T15
SM900100-032Z03050111W32P17						3			
SM900100-040Z03050111W32P17	4								
SM900100-040Z04050111W32P17	4								

Фрезы с каналами для подвода СОЖ изготавливаются по специальному заказу.

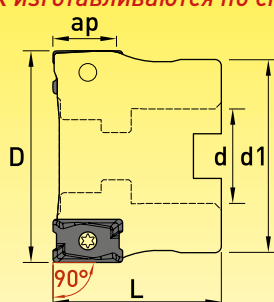

**ФРЕЗЫ ТОРЦОВЫЕ НАСАДНЫЕ
(угол в плане 90°)**



Артикул	D мм	L мм	d мм	d1 мм	ap мм	Z	Пластины	Винт	Ключ
SM900100-040Z0404000D16P12	40	40	16	37	11.5	4	SM0100KU-12.../ SM0100HU-12...	SDC3080	T10
SM900100-040Z0604000D16P12						6			
SM900100-040Z0704000D16P12	7								
SM900100-050Z0504000D22P12	50	40	22	42	5				
SM900100-050Z0704000D22P12					7				
SM900100-050Z0904000D22P12	50	40	22	50	9				
SM900100-063Z0604000D22P12					6				
SM900100-063Z0904000D22P12	63	40	22	50	9				
SM900100-080Z0805000D27P12					8				
SM900100-080Z1005000D27P12	80	50	27	60	10				
SM900100-040Z0404000D16P17					4	SM0100KU-17.../ SM0100HU-17...	SDC4013	T15	
SM900100-040Z0504000D16P17	5								
SM900100-050Z0404000D22P17	4								
SM900100-050Z0504000D22P17	5								
SM900100-050Z0604000D22P17	6								
SM900100-063Z0504000D22P17	5								
SM900100-063Z0604000D22P17	6								
SM900100-063Z0704000D22P17	7								
SM900100-080Z0505000D27P17	80	50	27	58	5				
SM900100-080Z0705000D27P17		7							
SM900100-080Z0905000D27P17	80	50	27	58	9				
SM900100-100Z0605000D32P17		6							
SM900100-100Z0805000D32P17	100	50	32	85	8				
SM900100-100Z1105000D32P17		11							
SM900100-125Z0706300D40P17	125	63	40	85	7				
SM900100-125Z0906300D40P17		9							
SM900100-125Z1206300D40P17	125	63	40	85	12				
SM900100-160Z0806300D40P17		8							
SM900100-160Z1206300D40P17	160	63	40	110	12				
SM900100-160Z1606300D40P17		16							

Фрезы с каналами для подвода СОЖ изготавливаются по специальному заказу.

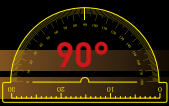

ПЛАСТИНЫ ДЛЯ ФРЕЗ: ТИП SM900100

ПЛАСТИНЫ ДЛЯ ФРЕЗ: ТИП SM900100

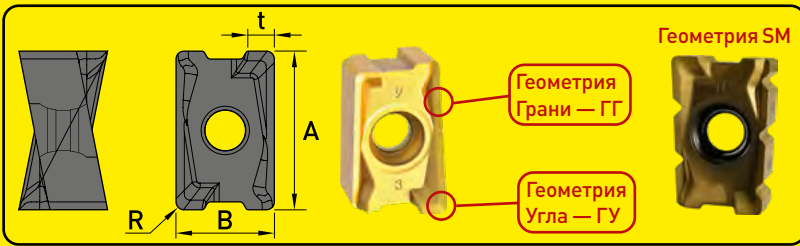

P	★		☆
M	★		★
K	☆	★	
N			
S	☆		☆
H			

УРП	Артикул	А мм	В мм	t мм	R мм	ар мм	fz мм/зуб	с покрытием		
								SU32	SK72	SM83
12	SM0100KU-120404PFR-M	12.55	7.0	1.7	0.4	1-9	0,06-0,15	●	●	●
	SM0100HU-120404PFR-M							●	●	●
	SM0100KU-120408PFR-M				0.8	2-10	0,08-0,15	●	●	●
	SM0100KU-120408PER-MM							●	●	●
	SM0100KU-120412PFR-M							1.2	●	●
17	SM0100KU-17T608PFR-M	17.3	10.4	2.7	0.8	2-15	0,10-0,20	●	●	●
	SM0100KU-17T608PER-MM							●	●	●
	SM0100HU-17T608PER-MM							●	●	●
	SM0100HU-17T608PER-M							●	●	●
	SM0100HU-17T608PER-SM							●	●	●
	SM0100KU-17T616PFR-M				1.6	2-14		●	●	●

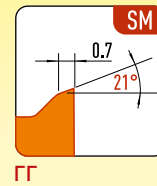
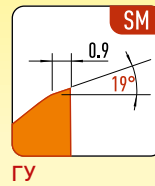
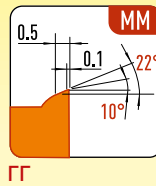
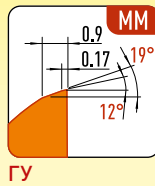
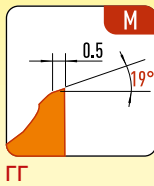
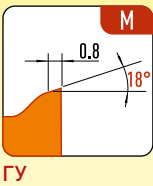

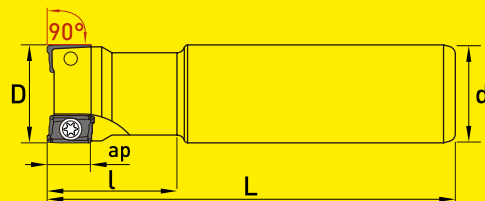

**ФРЕЗЫ КОНЦЕВЫЕ
С ЦИЛИНДРИЧЕСКИМ ХВОСТОВИКОМ
(угол в плане 90°)**



Артикул	D мм	L мм	L мм	d мм	ap мм	Z	Пластины	Винт	Ключ	
SM900111-025Z02040210S24P17	25	40	210	24	16.1	2	SM0111KT-17...	SDS4090	T15	
SM900111-025Z02040210S25P17			200							
SM900111-026Z02040200S25P17	26	40	200							
SM900111-026Z02040250S25P17			250							
SM900111-032Z02065250S32P17	32	65	200	32						3
SM900111-032Z03065200S32P17			300							
SM900111-033Z02040300S32P17	33	40	200	32						2
SM900111-033Z03055200S32P17			300							
SM900111-033Z03055250S32P17	33	55	200	32						3
SM900111-033Z03055250S32P17			250							
SM900111-040Z02054250S32P17	40	54	200	32	2					
SM900111-040Z03054200S32P17			200							
SM900111-040Z04057200S32P17			200							

Фрезы с каналами для подвода СОЖ изготавливаются по специальному заказу.

Фрезы с хвостовиком «WELDON» изготавливаются по специальному заказу.

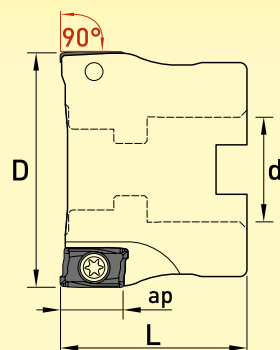

**ФРЕЗЫ ТОРЦОВЫЕ НАСАДНЫЕ
(угол в плане 90°)**



Артикул	D мм	L мм	d мм	T	ap мм	Z	Пластины	Винт	Ключ					
SM900111-050Z03040000D22P17	50	40	22	A	16.1	3	SM0111KT-17...	SDS4090	T15					
SM900111-050Z04040000D22P17						4								
SM900111-050Z05040000D22P17						5								
SM900111-063Z04040000D22P17	63	40	22			A				4				
SM900111-063Z06040000D22P17										6				
SM900111-080Z04050000D27P17						80				50	27	A	4	
SM900111-080Z06050000D27P17	6													
SM900111-080Z07050000D27P17	7													
SM900111-100Z06050000D32P17	100	50	32			B				16.1	6	SM0111KT-17...	SDS4090	T15
SM900111-100Z08050000D32P17											8			
SM900111-125Z07063000D40P17	125	63	40	B	7									
SM900111-125Z08063000D40P17					8									
SM900111-125Z09063000D40P17				9										
SM900111-160Z08063000D40P17	160	63	40	C	16.1		8	SM0111KT-17...	SDS4090		T15			
SM900111-160Z10063000D40P17							10							
SM900111-200Z12063000D60P17				200	63		60							

T — тип крепления на оправке

Фрезы с каналами для подвода СОЖ изготавливаются по специальному заказу.

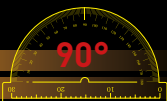

ФРЕЗЫ: ТИП SM900111

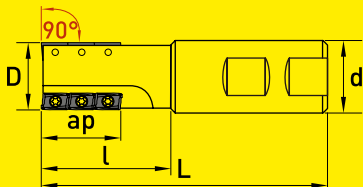

ФРЕЗЫ ТОРЦОВО-ЦИЛИНДРИЧЕСКИЕ С ХВОСТОВИКОМ WELDON (угол в плане 90°)



Артикул	D мм	L мм	L мм	d мм	ap мм	Z	Zn	Пластины	Винт	Ключ
SM900111-032Z02050120W32P17N04	32	50	120	32	30	2	4	SM0111KT-17...	SDS4090	T15
SM900111-040Z02065140W32P17N06	40	65	140		44		6			

Фрезы с каналами для подвода СОЖ изготавливаются по специальному заказу.

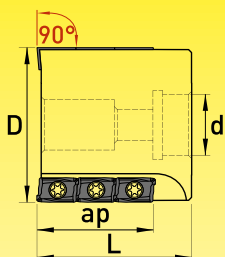

ФРЕЗЫ ТОРЦОВО-ЦИЛИНДРИЧЕСКИЕ НАСАДНЫЕ (угол в плане 90°)



Артикул	D мм	L мм	d мм	T	ap мм	Z	Zn	Пластины	Винт	Ключ
SM900111-050Z02060000D22P17N06	50	60	22	A	44	2	6	SM0111KT-17...	SDS4090	T15
SM900111-063Z03063000D27P17N09	63	63	27			3	9			
SM900111-063Z04063000D27P17N12	63	63	27			4	12			
SM900111-080Z04075000D32P17N16	80	75	32			5	16			
SM900111-100Z05110000D40P17N30	100	110	40			5	30			

T — тип крепления на оправке

Фрезы с каналами для подвода СОЖ изготавливаются по специальному заказу.

ПЛАСТИНЫ ДЛЯ ФРЕЗ: ТИП SM900111

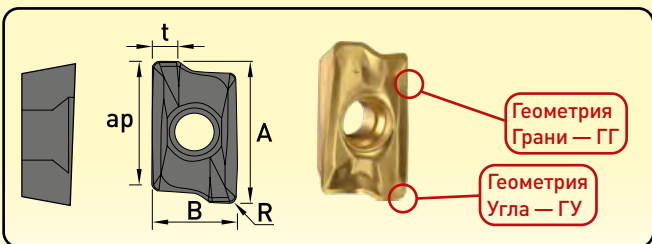

	★		★
P	★		★
M	★		★
K	☆	★	
N			
S	☆		
H			

С П Л А В Ы
с покрытием

УРП	Артикул	A мм	B мм	ap мм	t мм	R мм	ap мм	fz мм/зуб	SU32	SK74	SPM30
17	SM0111KT-1705PER-ME	18.5	10.7	16.1	2.26	0.8	1-13	0,08-0,17	●	●	
	SM0111KT-170516R-ME				2.54	1.6	2-13				●

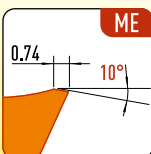

ГУ

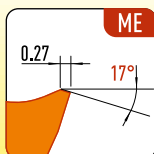

ГГ



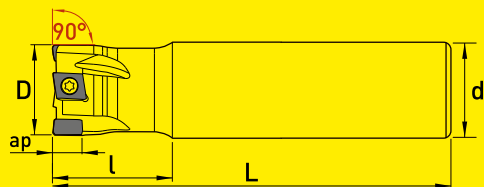

ФРЕЗЫ КОНЦЕВЫЕ
С ЦИЛИНДРИЧЕСКИМ ХВОСТОВИКОМ
(угол в плане 90°)



Артикул	D мм	L мм	L мм	d мм	ap мм	Z	Пластины	Винт	Ключ				
SM900800-020Z02030150S20P09	20	30	150	20	8.5	2	SM0800HU-09...	SS3010	T08				
SM900800-020Z03030150S20P09						3							
SM900800-025Z03030150S25P09	25			32		25				4			
SM900800-025Z04030150S25P09										3			
SM900800-032Z03030150S32P09	32			170		32				5			
SM900800-032Z05030150S32P09										4			
SM900800-040Z04030170S32P09	40	170	32	6									
SM900800-040Z06030170S32P09				2									
SM900800-030Z02035150S25P12	30	35	150	25	11.5	3				SM0800HU-12...	SS4013	T15	
SM900800-030Z03035150S25P12						2							
SM900800-032Z02035150S32P12	32			32		32							3
SM900800-032Z03035150S32P12													2
SM900800-035Z02035150S32P12	35			170		32	3						
SM900800-035Z03035150S32P12							4						
SM900800-040Z03035170S32P12	40	170	32	3									
SM900800-040Z04035170S32P12				4									

Фрезы с каналами для подвода СОЖ изготавливаются по специальному заказу.
Фрезы с хвостовиком «WELDON» изготавливаются по специальному заказу.

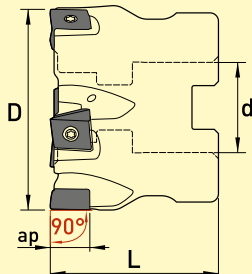

ФРЕЗЫ ТОРЦОВЫЕ НАСАДНЫЕ
(угол в плане 90°)

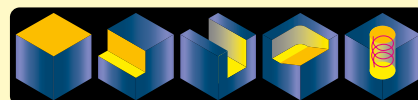

Артикул	D мм	L мм	d мм	T	ap мм	Z	Пластины	Винт	Ключ															
SM900800-050Z05040000D22P09	50	40	22	A	8.5	5	SM0800HU-09...	SS3010	T08															
SM900800-050Z07040000D22P09						7																		
SM900800-063Z06040000D22P09						63				50	27	11.5	6											
SM900800-063Z10040000D22P09	10																							
SM900800-050Z04040000D22P12	50					50				32	B	15.0	4	SM0800HU-12...	SS4013	T15								
SM900800-050Z06040000D22P12													6											
SM900800-063Z06040000D22P12	63	63	40	C	15.0	8				SM0800HU-16...	SS5016	T20												
SM900800-063Z08040000D22P12						7																		
SM900800-080Z07050000D27P12	80	63	40	C	15.0	10							SM0800HU-16...				SS5016	T20						
SM900800-080Z10050000D27P12						8																		
SM900800-100Z08050000D32P12	100	63	40	C	15.0	12													SM0800HU-16...	SS5016	T20			
SM900800-100Z12050000D32P12						10																		
SM900800-125Z10063000D40P12	125	63	40	C	15.0	14	SM0800HU-16...	SS5016	T20															
SM900800-125Z14063000D40P12						11																		
SM900800-160Z11063000D40P16	160	63	40	C	15.0	14																SM0800HU-16...	SS5016	T20
SM900800-160Z14063000D40P16						12																		
SM900800-200Z12063000D60P16	200	63	60	C	15.0	16								SM0800HU-16...	SS5016	T20								
SM900800-200Z16063000D60P16						16																		

T — тип крепления на оправке

Фрезы с каналами для подвода СОЖ изготавливаются по специальному заказу.

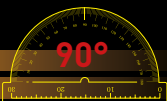

ФРЕЗЫ: ТИП SM900800 С ТАНГЕНЦИАЛЬНЫМ КРЕПЛЕНИЕМ ПЛАСТИН

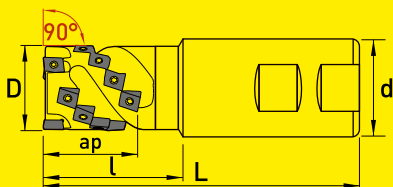
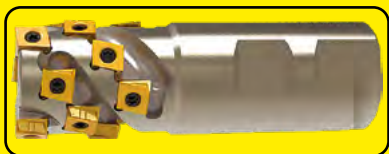

ФРЕЗЫ ТОРЦОВО-ЦИЛИНДРИЧЕСКИЕ С ХВОСТОВИКОМ WELDON (угол в плане 90°)



Артикул	D мм	l мм	L мм	d мм	ap мм	Z	Zn	Пластины	Винт	Ключ
SM900800-025Z02043100W25P09N10	25	43	100	25	36	2	10	SM0800HU-09...	SS3010	T08
SM900800-032Z03044105W32P09N15	32	44	105	32						
SM900800-032Z03052115W32P09N18		52	115		43	18				
SM900800-040Z03054125W40P09N18	40	54	125	40			51			
SM900800-040Z03064135W40P09N21		64	135							

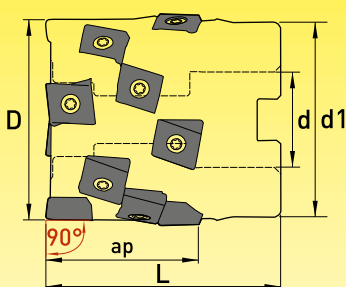

ФРЕЗЫ ТОРЦОВО-ЦИЛИНДРИЧЕСКИЕ НАСАДНЫЕ (угол в плане 90°)



Артикул	D мм	L мм	d мм	d1 мм	ap мм	Z	Zn	Пластины	Винт	Ключ
SM900800-050Z03055000D22P12N09	50	55	22	45	31.5	3	9	SM0800HU-12...	SS4013	T15
SM900800-050Z03065000D22P12N12		65								
SM900800-063Z04070000D27P12N16	63	70	74	5	20					
SM900800-063Z04080000D27P12N20		80				94	20			
SM900800-080Z05085000D32P12N25	85	100	100	5	20					
SM900800-100Z05090000D40P16N20	90					40				

ПЛАСТИНЫ ДЛЯ ФРЕЗ: ТИП SM90800

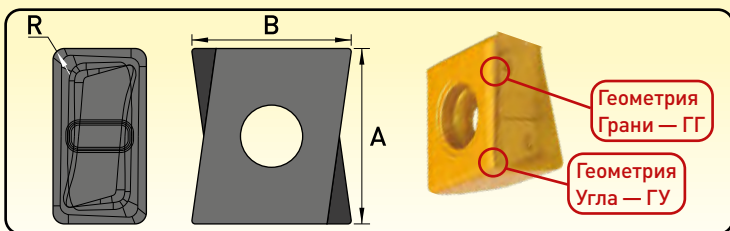

	★	☆	☆	★
P	★		☆	
M	★		★	
K	☆	★		
N				★
S	☆		☆	
H				

УРП	Артикул	А мм	В мм	ap мм	R мм	ap мм	fz мм/зуб	С П Л А В Ы			
								с покрытием		без покрытия	
								SU32	SK72	SM83	SN20
09	SM0800HU-090404-M	9.02	8.55	8.5	0.4	1-8.0	0.06-0.15	●	●	●	
12	SM0800HU-120608-M	12.70	13.00	11.5	0.8	1-10.5	0.10-0.20	●	●	●	
	SM0800HU-120612-M							●	●	●	
	SM0800HU-120608-AL							●	●	●	●
16	SM0800HU-160808-M	16.40	16.20	15.0	0.8	2-15.0	0.10-0.20	●	●	●	●

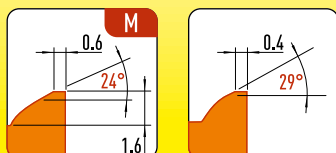

ГУ

ГГ

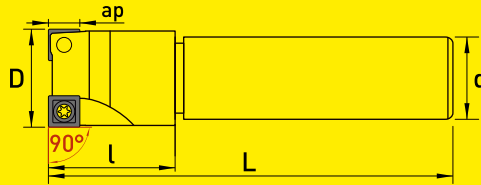

**ФРЕЗЫ КОНЦЕВЫЕ
С ЦИЛИНДРИЧЕСКИМ ХВОСТОВИКОМ
(угол в плане 90°)**



Артикул	D мм	l мм	L мм	d мм	ap мм	Z	Пластины	Винт	Ключ
SM901315-040Z03040170S32P14	40	40	170	32	10	3	SM1315KT-1404...	SDS3585	T10
SM901315-040Z03040250S32P14			250			4			
SM901315-040Z04040170S32P14			170			3			
SM901315-050Z03040120S32P14	50	40	120	3					
SM901315-050Z04040120S32P14				4					
SM901315-063Z04040120S32P14	63	40	120	4					
SM901315-063Z05040120S32P14				5					

Фрезы с каналами для подвода СОЖ изготавливаются по специальному заказу.

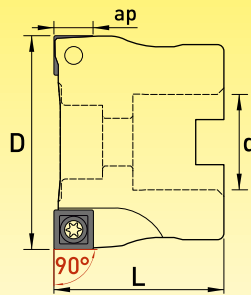

**ФРЕЗЫ ТОРЦОВЫЕ НАСАДНЫЕ
(угол в плане 90°)**



Артикул	D мм	L мм	d мм	T	ap мм	Z	Пластины	Винт	Ключ
SM901315-050Z05040000D22P14	50	40	22	A	10	5	SM1315KT-1404...	SDS3585	T10
SM901315-063Z06040000D22P14	63		27						
SM901315-080Z06050000D27P14	80	50	27	B	8				
SM901315-080Z08050000D27P14					10				
SM901315-100Z08050000D32P14	100	50	32	C	10				
SM901315-100Z10050000D32P14					12				
SM901315-125Z10063000D40P14	125	63	40	C	15				
SM901315-125Z12063000D40P14					15				
SM901315-160Z15063000D40P14	160	63	40	C	15				

T — тип крепления на оправке

Фрезы с каналами для подвода СОЖ изготавливаются по специальному заказу.

ПЛАСТИНЫ ДЛЯ ФРЕЗ: ТИП SM901315

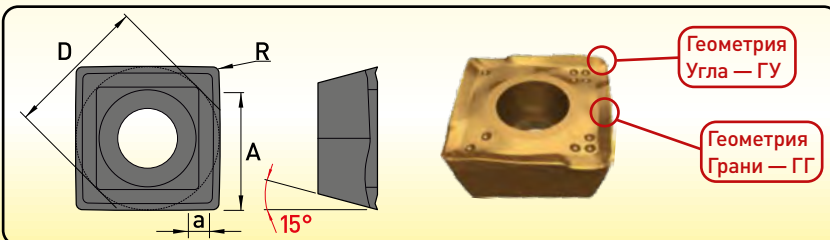

	★		☆
P	★		☆
M	★		★
K		★	
N			
S			★
H			

С П Л А В Ы
с покрытием

УРП	Артикул	D мм	A мм	a мм	R мм	ap мм	fz мм/зуб	SPM30	SK74	SMS84
14	SM1315KT-140408-MP	13.8	10.3	2.0	0.8	1-9.2	0.09-0.18	●	●	●

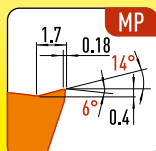
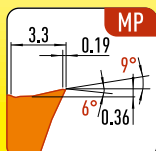

ГУ

ГГ

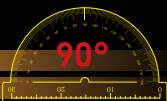

ФРЕЗЫ: ТИП SM9013XX

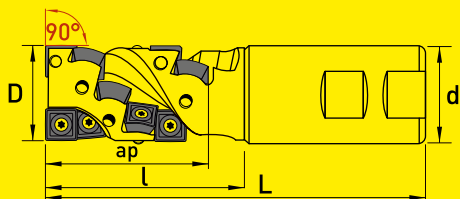

ФРЕЗЫ ТОРЦОВО-ЦИЛИНДРИЧЕСКИЕ С ХВОСТОВИКОМ WELDON (угол в плане 90°)



Артикул	D мм	l мм	L мм	d мм	ap мм	Z	Zn	Пластины	Винт	Ключ
SM9013XX-025Z02058120W25P09N12	25	58	120	25	40	2	12	SM13XXKT-09T3...	SDS3585	T15
SM9013XX-032Z03070135W32P09N21	32	70	135	32	52	3	21			
SM9013XX-032Z02070135W32P11N12						40	2	12		
SM9013XX-040Z03075135W32P11N18	75	60	3	18						
SM9013XX-040Z03085180W32P11N21	85		21							
SM9013XX-050Z04075145W40P11N24	50	75	145	40	52	4	24	SM13XXKT-1104...	SD4010	
SM9013XX-050Z04100170W40P11N36	50	100	170	40	76	4	36			

Фрезы с каналами для подвода СОЖ изготавливаются по специальному заказу.

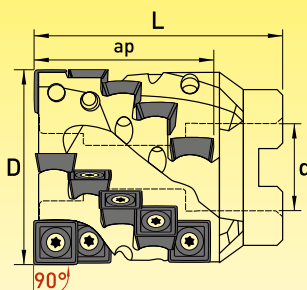

ФРЕЗЫ ТОРЦОВО-ЦИЛИНДРИЧЕСКИЕ НАСАДНЫЕ (угол в плане 90°)

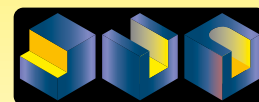

Артикул	D мм	L мм	d мм	ap мм	Z	Zn	Пластины	Винт	Ключ
SM9013XX-040Z03055000D16P11N09	40	55	16	27	3	9	SM13XXKT-1104...	SD4010	T15
SM9013XX-050Z04065000D22P11N20	50	65	22	43	4	20			
SM9013XX-050Z04090000D22P11N32		90		69		32			
SM9013XX-063Z05085000D27P11N35	63	85	27	60	5	35			
SM9013XX-063Z05093000D27P11N40		93		69		40			
SM9013XX-080Z06100000D32P11N54		80	100	32	76	6			

Фрезы с каналами для подвода СОЖ изготавливаются по специальному заказу.

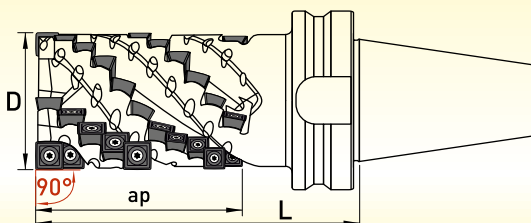
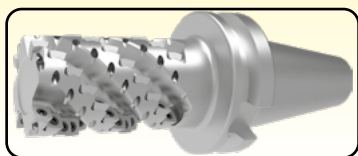

ФРЕЗЫ ТОРЦОВО-ЦИЛИНДРИЧЕСКИЕ НАСАДНЫЕ (угол в плане 90°). ХВОСТОВИК BT50 MAS403-BT

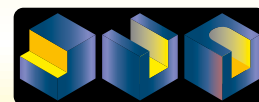

Артикул	D мм	L мм	ap мм	Z	Zn	Пластины	Винт	Ключ
SM9013XX-050Z03075140BT50P11N27	50	140	75	3	27	SM13XXKT-1104...	SD4010	T15
SM9013XX-050Z02105170BT50P11N30		170	105	2	30			
SM9013XX-063Z04095160BT50P11N44	63	160	95	4	44			
SM9013XX-063Z02126200BT50P11N36		200	126	2	36			
SM9013XX-080Z04120200BT50P11N56	80	200	120	4	56			
SM9013XX-080Z02160240BT50P11N44		240	160	2	44			

Фрезы с каналами для подвода СОЖ изготавливаются по специальному заказу.

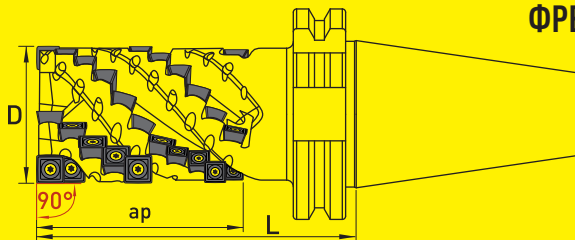
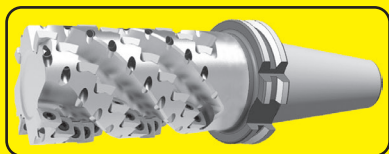

ФРЕЗЫ ТОРЦОВО-ЦИЛИНДРИЧЕСКИЕ
НАСАДНЫЕ (угол в плане 90°).
ХВОСТОВИК SK50 DIN 69871



Артикул	D мм	L мм	ap мм	Z	Zn	Пластины	Винт	Ключ
SM9013XX-050Z03075121SK50P11N27	50	121	75	3	27	SM13XXKT-1104...	SS4010	T15
SM9013XX-050Z02105151SK50P11N30		151	105	2	30			
SM9013XX-063Z04095141SK50P11N44	63	141	95	4	44			
SM9013XX-063Z02126181SK50P11N36		181	126	2	36			
SM9013XX-080Z04120181SK50P11N56	80		221	120	4			
SM9013XX-080Z02160221SK50P11N44		221	160	2	44			

Фрезы с каналами для подвода СОЖ изготавливаются по специальному заказу.

Фрезы других диаметров и с другими геометрическими размерами, а также фрезы с хвостовиком DIN 2080 изготавливаются по специальному заказу.

ПЛАСТИНЫ ДЛЯ ФРЕЗ: ТИП SM9013XX

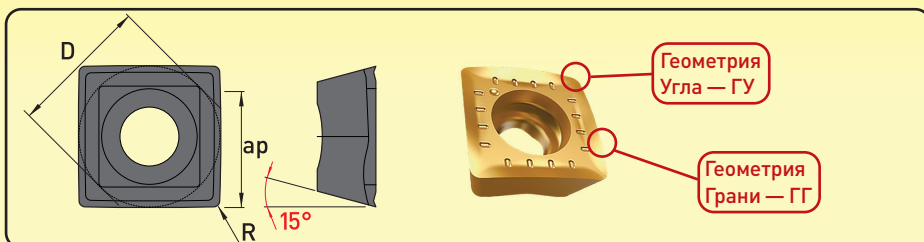

	★		☆
P	★		☆
M	★		★
K	☆	★	
N			
S	☆		☆
H			

С П Л А В Ы
с покрытием

УРП	Артикул	D мм	ap мм	R мм	ap мм	fz мм/зуб	SU32	SK72	SM83
09	SM13XXKT-09T308-M	9.525	8.5	0.8	1-8.5	0.04-0.15	●	●	●
11	SM13XXKT-110408-LM	11.000	10.0		1-10.0	0.04-0.15	●	●	●

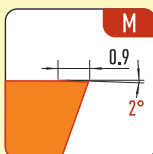

ГУ

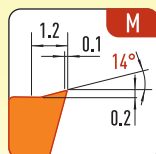

ГГ

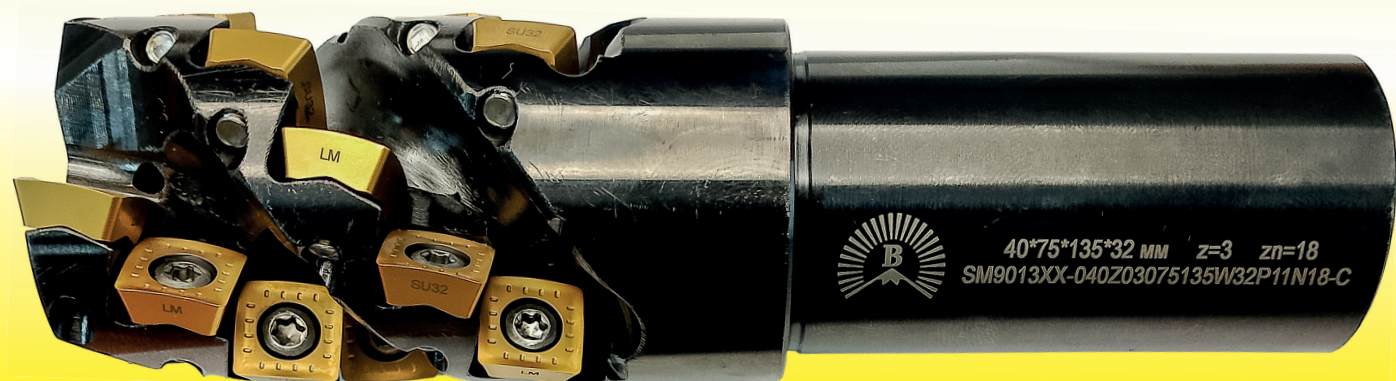

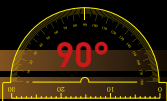

ФРЕЗЫ: ТИП SM908800

ГОЛОВКИ ФРЕЗЕРНЫЕ С РЕЗЬБОВЫМ ХВОСТОВИКОМ (угол в плане 90°)



Рис. 1



Рис. 2

Фрезы и пластины данной серии полностью взаимозаменяемы с фрезами и пластинами серии 6NGU торговой марки «Taegu Tes».

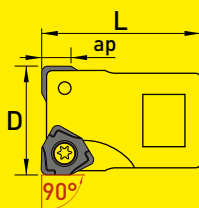
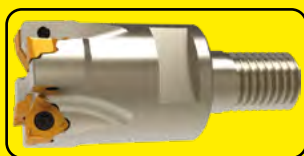

Артикул	Рис.	D мм	L мм	d мм	ap мм	M	Z	Каналы СОЖ	Пластины	Винт	Ключ	
SM908800-025Z02035000M12P06	1	25	35	21		M12	2	—	SM8800GU-0604...	SDC3080	T08	
SM908800-025Z02035000M12P06-C	2						✓					
SM908800-032Z03043000M16P06	1	32			6.2		3	—				
SM908800-032Z03043000M16P06-C	2						✓					
SM908800-040Z04043000M16P06	1	40					4	—				
SM908800-040Z04043000M16P06-C	2						✓					
SM908800-032Z02043000M16P09	1	32	43	29		M16	2	—		SM8800GU-0905...	SS4010	T15
SM908800-032Z02043000M16P09-C	2						✓					
SM908800-040Z03043000M16P09	1	40				9.2	3	—				
SM908800-040Z03043000M16P09-C	2						✓					
SM908800-040Z04043000M16P09	1	40					4	—				
SM908800-040Z04043000M16P09-C	2						✓					

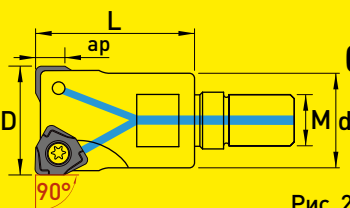
Данные фрезы изготавливаются по специальному заказу. Минимальная партия и срок поставки — по запросу.



Рис. 1



Рис. 2

ФРЕЗЫ КОНЦЕВЫЕ С ЦИЛИНДРИЧЕСКИМ ХВОСТОВИКОМ (угол в плане 90°)

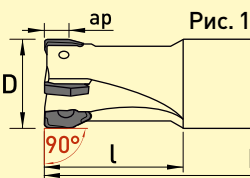
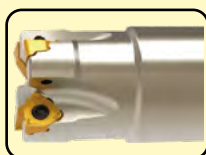
Фрезы и пластины данной серии полностью взаимозаменяемы с фрезами и пластинами серии 6NGU торговой марки «Taegu Tes».

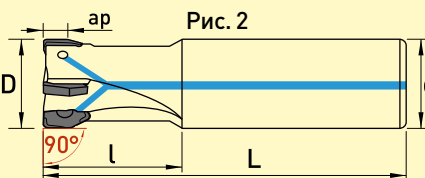

Артикул	Рис.	D мм	l мм	L мм	d мм	ap мм	Z	Каналы СОЖ	Пластины	Винт	Ключ	
SM908800-025Z02030150S25P06	1	25	30	150	25			—	SM8800GU-0604...	SDC3080	T08	
SM908800-025Z02030150S25P06-C	2							✓				
SM908800-032Z02040160S32P06	1	32		160		6.2		—				
SM908800-032Z02040160S32P06-C	2							✓				
SM908800-032Z03040160S32P06	1	40			32			—				
SM908800-032Z03040160S32P06-C	2							✓				
SM908800-040Z03040200S32P06	1	40		200				—				
SM908800-040Z03040200S32P06-C	2							✓				
SM908800-032Z02060160S32P09	1	32	60	160			9.2	2		SM8800GU-0905...	SS4010	T15
SM908800-032Z02060160S32P09-C	2							✓				
SM908800-040Z03040200S32P09	1	40	40	200				—				
SM908800-040Z03040200S32P09-C	2							✓				

Данные фрезы изготавливаются по специальному заказу. Минимальная партия и срок поставки — по запросу.

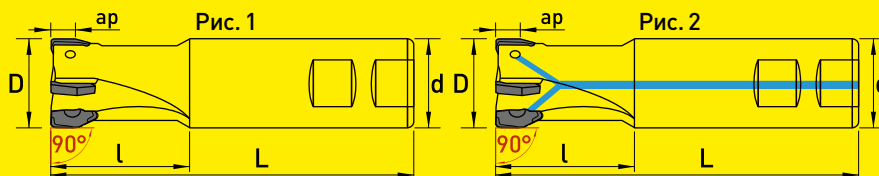

**ФРЕЗЫ КОНЦЕВЫЕ
С ХВОСТОВИКОМ
WELDON
(угол в плане 90°)**

Фрезы и пластины данной серии полностью взаимозаменяемы с фрезами и пластинами серии 6NGU торговой марки «Taegu Tec».



Артикул	Рис.	D мм	L мм	L мм	d мм	ap мм	Z	Каналы СОЖ	Пластины	Винт	Ключ	
SM908800-025Z02030100W25P06	1	25	30	100	25		2	-	SM8800GU-0604...	SDC3080	T08	
SM908800-025Z02030100W25P06-C	2							✓				
SM908800-032Z02040110W32P06	1	32		110		6.2	3	-				
SM908800-032Z02040110W32P06-C	2							✓				
SM908800-032Z03040110W32P06	1	40	40	115	32		4	-				
SM908800-040Z03040115W32P06	1							-				
SM908800-040Z03040115W32P06-C	2							✓				
SM908800-040Z04040115W32P06	1							-				
SM908800-040Z04040115W32P06-C	2	✓										
SM908800-032Z02040110W32P09	1	32		110		9.2	2	-		SM8800GU-0905...	SS4010	T15
SM908800-032Z02040110W32P09-C	2							✓				
SM908800-040Z03040120W32P09	1	40		120		9.2	3	-				
SM908800-040Z03040120W32P09-C	2							✓				
SM908800-040Z04040120W32P09	1							-				
SM908800-040Z04040120W32P09-C	2							✓				

Данные фрезы изготавливаются по специальному заказу. Минимальная партия и срок поставки — по запросу.

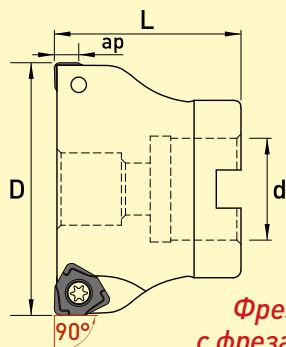

**ФРЕЗЫ ТОРЦОВЫЕ НАСАДНЫЕ
(угол в плане 90°)**



Фрезы и пластины данной серии полностью взаимозаменяемы с фрезами и пластинами серии 6NGU торговой марки «Taegu Tec».

Артикул	D мм	L мм	d мм	T	ap мм	Z	Пластины	Винт	Ключ			
SM908800-040Z04040000D16P06	40	40	16	A		6.2	SM8800GU-0604...	SDC3080	T08			
SM908800-050Z04040000D22P06	50									22	7	4
SM908800-050Z06040000D22P06												6
SM908800-063Z04040000D22P06	63									22	7	4
SM908800-063Z06040000D22P06		6										
SM908800-080Z05050000D27P06	80	50	27	B	11	5						
SM908800-080Z07050000D27P06						7						
SM908800-080Z09050000D27P06	100	50	32	B	11	9						
SM908800-100Z06050000D32P06						6						
SM908800-100Z08050000D32P06	100	50	32	B	11	8						
SM908800-100Z11050000D32P06						7						
SM908800-125Z07063000D40P06	125	63	40	B	14	7						
SM908800-125Z11063000D40P06						11						
SM908800-125Z14063000D40P06						14						

T — тип крепления на оправке

Фрезы с каналами для подвода СОЖ изготавливаются по специальному заказу.

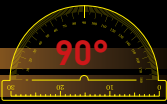

ФРЕЗЫ: ТИП SM908800

ФРЕЗЫ ТОРЦОВЫЕ НАСАДНЫЕ (угол в плане 90°)

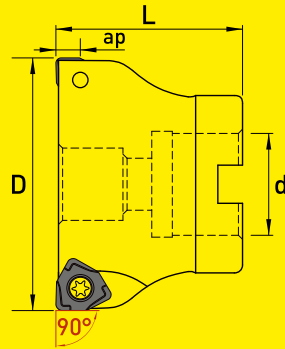

Продолжение таблицы

Артикул	D мм	L мм	d мм	T	ap мм	Z	Пластины	Винт	Ключ		
SM908800-050Z04040000D22P09	50	40	22	A	9.2	4	SM8800GU-0905...	SDS4010	T15		
SM908800-050Z05040000D22P09						5					
SM908800-063Z04040000D22P09	4										
SM908800-063Z06040000D22P09	6										
SM908800-063Z07040000D22P09	7										
SM908800-080Z05050000D27P09	80	50	27			5					
SM908800-080Z07050000D27P09						7					
SM908800-080Z09050000D27P09						9					
SM908800-100Z06050000D32P09	100					63				32	6
SM908800-100Z08050000D32P09											8
SM908800-100Z11050000D32P09				11							
SM908800-125Z07063000D40P09	125	63	40	B	7						
SM908800-125Z11063000D40P09					11						
SM908800-125Z14063000D40P09					14						
SM908800-160Z12063000D40P09	160				63	40				C	12
SM908800-160Z16063000D40P09											16
SM908800-200Z14063000D60P09											14
SM908800-200Z18063000D60P09	200	60	60								18
SM908800-250Z18063000D60P09											18
SM908800-250Z22063000D60P09											22

T — тип крепления на оправке

Фрезы с каналами для подвода СОЖ изготавливаются по специальному заказу.

ПЛАСТИНЫ ДЛЯ ФРЕЗ: ТИП SM908800

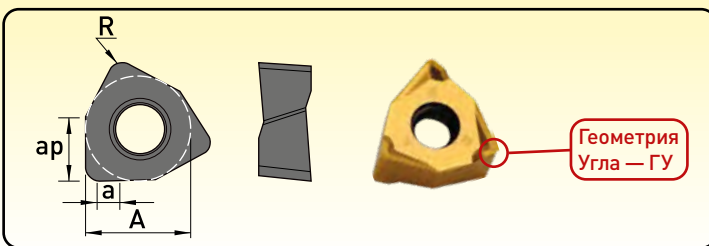

	★	★		
P	★	★		
M	★	★		
K	☆		★	★
N				
S	☆			
H				

УРП	Артикул	A мм	ap мм	a мм	R мм	ap мм	fz мм/зуб	С П Л А В Ы			
								SU32	SPM30	SK72	SK74
06	SM8800GU-060408-M	9.26	6.2	1.96	0.8	1.5-5.0	0.08-0.15	●	●	●	●
	SM8800GU-090508-M							●	●	●	●
	SM8800GU-090508-LM								●		●
	SM8800MU-090508R-M								●		●

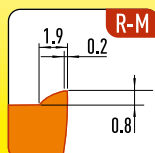
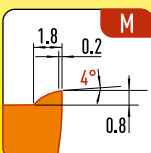

ГУ

ГУ

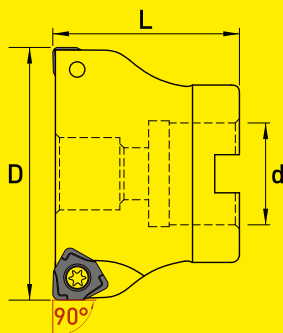

ФРЕЗЫ ТОРЦОВЫЕ НАСАДНЫЕ
(угол в плане 90°)



Артикул	D мм	L мм	d мм	T	ар мм	Z	Пластины	Винт	Ключ
SM901600-050Z04040000D22P08	50	40	22	A	7.5	4	SM1600HX-0806...	SDS4013P	T15
SM901600-050Z05040000D22P08						5			
SM901600-063Z04040000D22P08	4								
SM901600-063Z06040000D22P08	6								
SM901600-063Z07040000D22P08	7								
SM901600-063Z06040000D27P08	6								
SM901600-063Z07040000D27P08	7								
SM901600-080Z05050000D27P08	80	50	27	B		5			
SM901600-080Z07050000D27P08						7			
SM901600-080Z09050000D27P08						9			
SM901600-100Z06050000D32P08	100	63	40	C		6			
SM901600-100Z08050000D32P08						8			
SM901600-100Z11050000D32P08						11			
SM901600-125Z07063000D40P08	125	63	40	C		7			
SM901600-125Z11063000D40P08						11			
SM901600-125Z14063000D40P08						14			
SM901600-160Z12063000D40P08					12				
SM901600-160Z14063000D40P08	160					16			

T — тип крепления на оправке

Фрезы с каналами для подвода СОЖ изготавливаются по специальному заказу.

ПЛАСТИНЫ ДЛЯ ФРЕЗ: ТИП SM901600

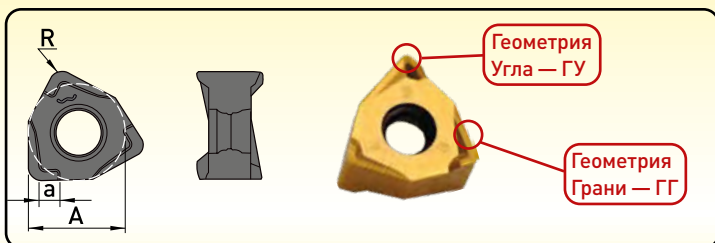

P	★	
M	★	
K	☆	★
N		
S	☆	
H		

С П Л А В Ы
с покрытием

УРП	Артикул	A мм	a мм	R мм	ар мм	fz мм/зуб	SU32	SK74
08	SM1600HX-080608-LM	12.48	1.2 ~ 2.0	0.8	1,5-7	0,1-0,3	●	●
	SM1600HX-080608-RT						●	

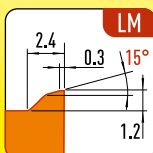

ГУ

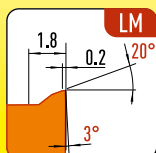

ГГ

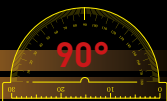

ФРЕЗЫ: ТИП SM901300

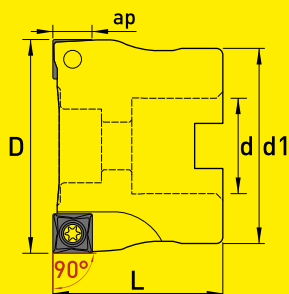

**ФРЕЗЫ ТОРЦОВЫЕ НАСАДНЫЕ
ДЛЯ ОБРАБОТКИ УСТУПОВ И ПАЗОВ**
(угол в плане 90°) с мощными квадратными
4-гранными двусторонними пластинами
(8 режущих кромок). Крепление винтом



Артикул	D мм	L мм	d мм	d1 мм	T	ap мм	Z	Пластины	Винт	Ключ
SM901300-050Z04040000D22P1205	50	40	22	47	A	10	4	SM1300HX-1205	SDS4013P	T15
SM901300-050Z05040000D22P1205	50	40	22	47	A	10	5			
SM901300-063Z05040000D22P1205	63	40	22	47	A	10	5			
SM901300-063Z07040000D22P1205	63	40	22	47	A	10	7			
SM901300-080Z05050000D27P1205	80	50	27	58	A	10	5			
SM901300-080Z07050000D27P1205	80	50	27	58	A	10	7			
SM901300-100Z06050000D32P1205	100	50	32	70	B	10	6			
SM901300-100Z08050000D32P1205	100	50	32	70	B	10	8			
SM901300-125Z07063000D40P1205	125	63	40	85	B	10	7			
SM901300-125Z10063000D40P1205	125	63	40	85	B	10	10			
SM901300-160Z08063000D40P1205	160	63	40	110	C	10	8			
SM901300-160Z12063000D40P1205	160	63	40	110	C	10	12			

T — тип крепления на оправке

Фрезы с каналами для подвода СОЖ изготавливаются по специальному заказу.

ПЛАСТИНЫ ДЛЯ ФРЕЗ: ТИП SM901300
Мощные квадратные двусторонние пластины.
Восемь режущих кромок с высокопозитивной
геометрией и винтовой кромкой

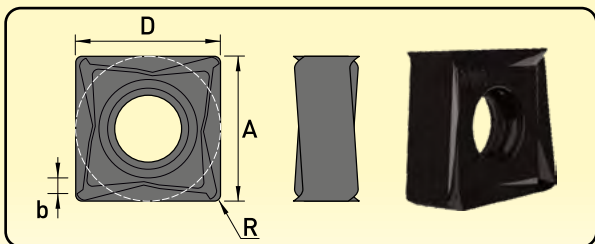

P	★		☆
M	★		★
K		★	
N			
S			★
H			

С П Л А В Ы
с покрытием

УРП	Артикул	D мм	A мм	b мм	R мм	ap мм	fz мм/зуб	SPM30	SK74	SMS84
12	SM1300HX-120508-M	12.7	12.7	1.34	0.8	1-6	0.1-0.2	●	●	●

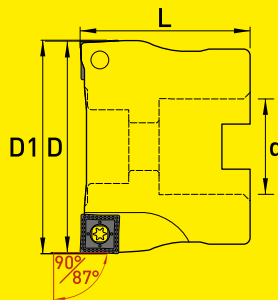

ФРЕЗЫ ТОРЦОВЫЕ НАСАДНЫЕ
(угол в плане 90°/87°)



Артикул	IS*	D мм	D1 мм	L мм	d мм	T	ар мм	Z	Пластины	Винт	Ключ
SM871300-050Z04040000D22P13	●	50	50.84	40	22	A	2-10	4	SM1300GX-1306...	SS4010	T15
SM871300-050Z05040000D22P13								5			
SM871300-063Z05040000D22P13	●	63	63.52	50	27			5			
SM871300-063Z06040000D22P13								6			
SM871300-080Z06050000D27P13	●	80	80.60	50	32			7			
SM871300-080Z07050000D27P13								9			
SM871300-080Z09050000D27P13						7					
SM871300-100Z07050000D32P13	●	100	100.58	63	40	B	8				
SM871300-100Z08050000D32P13							13				
SM871300-100Z13050000D32P13							10				
SM871300-125Z10063000D40P13		125	125.72	40	16						
SM871300-125Z16063000D40P13											

IS* — неравномерный шаг зуба

T — тип крепления на оправке

Фрезы с каналами для подвода СОЖ изготавливаются по специальному заказу.

ПЛАСТИНЫ ДЛЯ ФРЕЗ: ТИП SM871300

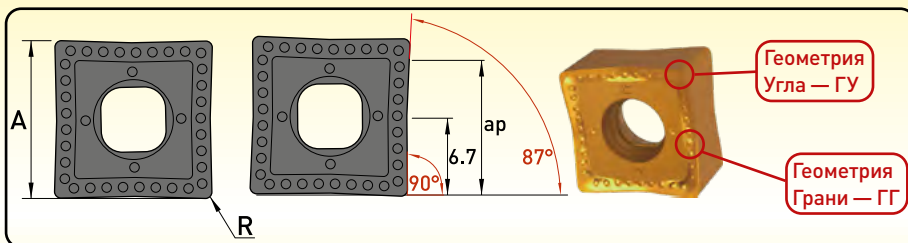

	P	M	K	N	S	H
★	☆					
★		★				
☆	★				★	
☆			☆			

УРП	Артикул	А мм	ар мм	R мм	ар мм	fz мм/зуб	С П Л А В Ы			
							с покрытием		без покрытия	
							SU32	SK72	SM83	SN20
13	SM1300GX-130608-M	13.50	2-10	0.8	2-10	0.1-0.2	●	●	●	
	SM1300GX-130608-LM						●	●	●	
	SM1300GX-130608-SAL									●

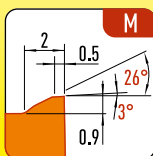

ГУ

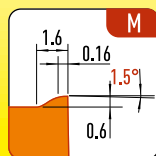

ГГ

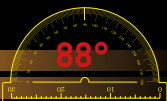

ФРЕЗЫ: ТИП SM881300

ФРЕЗЫ ТОРЦОВЫЕ НАСАДНЫЕ (угол в плане 88°)

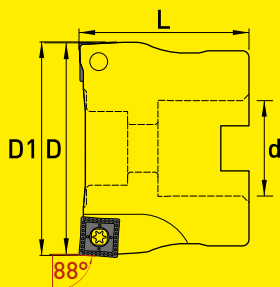

Артикул	IS*	D мм	D1 мм	L мм	d мм	T	ар мм	Z	Пластины	Винт	Ключ
SM881300-050Z04040000D22P13	●	50	51.0	40	22	A		4	SM1300GV-130608	SS4010	T15
SM881300-050Z05040000D22P13								5			
SM881300-063Z05040000D22P13	●	63	64.0					5			
SM881300-063Z06040000D22P13								6			
SM881300-080Z06050000D27P13	●	80	81.0					6			
SM881300-080Z07050000D27P13								7			
SM881300-080Z09050000D27P13								9			
SM881300-100Z07050000D32P13	●	100	101.0	50			2-10	7			
SM881300-100Z08050000D32P13								8			
SM881300-100Z11050000D32P13								11			
SM881300-125Z10063000D40P13		125	125.9					10			
SM881300-125Z14063000D40P13								14			
SM881300-160Z12063000D40P13		160	160.8	63				12			
SM881300-160Z18063000D40P13								18			
SM881300-200Z14063000D60P13								14			
SM881300-200Z22063000D60P13		200	200.8					14			
								22			

IS* — неравномерный шаг зуба

T — тип крепления на оправке

Фрезы с каналами для подвода СОЖ изготавливаются по специальному заказу.

ПЛАСТИНЫ ДЛЯ ФРЕЗ: ТИП SM881300

Экономичные двусторонние пластины.

Восемь режущих кромок имеют большой передний угол, что обеспечивает мягкое и быстрое резание.

Применяются для ступенчатого и торцевого фрезерования

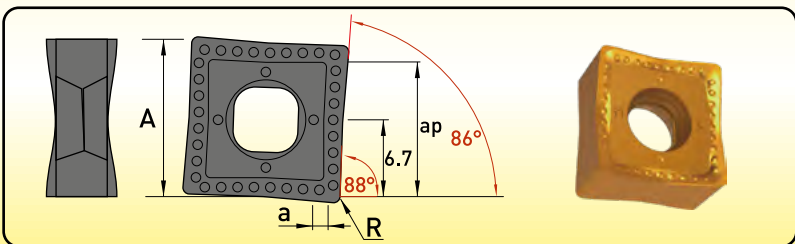

P	★		☆
M	★		★
K	☆	★	
N			
S	☆		☆
H			

С П Л А В Ы
с покрытием

УРП	Артикул	A мм	a мм	ар мм	R мм	ар мм	fz мм/зуб	SU32	SK72	SM83
13	SM1300GV-130608-M	13.50	2.2	2-10	0.8	2-10	0.1-0.2	●	●	●
	SM1300GV-130608-LM							●	●	●

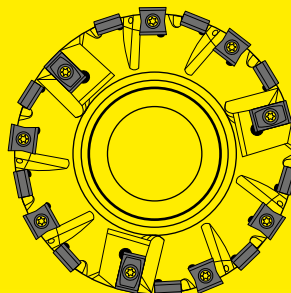
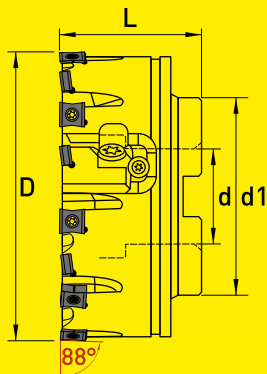

ФРЕЗЫ ТОРЦОВЫЕ НАСАДНЫЕ
(угол в плане 88°)



Артикул	D мм	L мм	d мм	d1 мм	T	Z	Пластины	Винт	Ключ
SM880800KG-080Z10050000D27P1015	80*	50	27	58	A	2+8	SM0800KX-1005... SM0800GX-1504...	SDC3080 SDS4090	T10 T15
SM880800KG-100Z12050000D32P1015	100	50	32	70		2+10			
SM880800KG-125Z18063000D40P1015	125	63	40	85	B	3+15			
SM880800KG-160Z21063000D40P1015	160			110		3+18			
SM880800KG-200Z27070000D60P1015	200	70	60	130	C	3+24			
SM880800KG-250Z32070000D60P1015	250			160		4+28			

T — тип крепления на оправке

Фрезы поставляются в сборе с регулируемыми картриджами.

*Фрезы диаметром 80 мм не имеют регулируемых картриджей.

ПЛАСТИНЫ ДЛЯ ФРЕЗ: ТИП SM880800KG

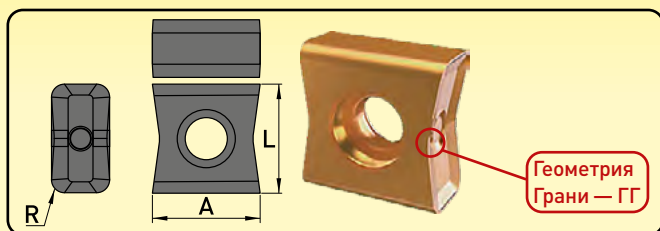

P	★
M	★
K	☆
N	☆
S	☆
H	☆

С П Л А В Ы
с покрытием

УРП	Артикул	L мм	A мм	R мм	ар мм	fz мм/зуб	SU32
10	SM0800KX-100512-LM	10.00	9.53	1.2	0.03-2.00	0.10-0.25	●

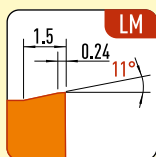

ГГ

ПЛАСТИНЫ ДЛЯ ФРЕЗ: ТИП SM880800KG

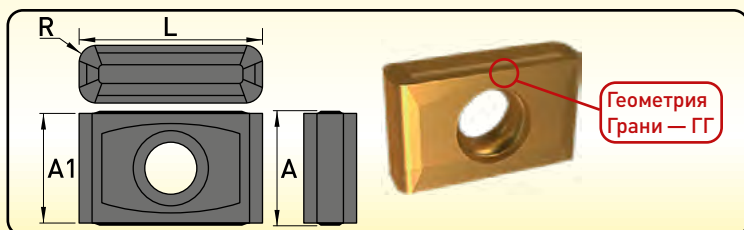

P	★	
M	★	
K	☆	★
N	☆	
S	☆	
H	☆	

С П Л А В Ы
с покрытием

УРП	Артикул	L мм	A1 мм	A мм	R мм	ар мм	fz мм/зуб	SU32	SK74
15	SM0800GX-15041-WLM	15.87	9.37	9.52	1.2	0.03-2.00	0.10-0.25	●	●

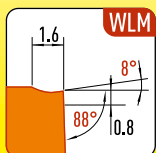

ГГ

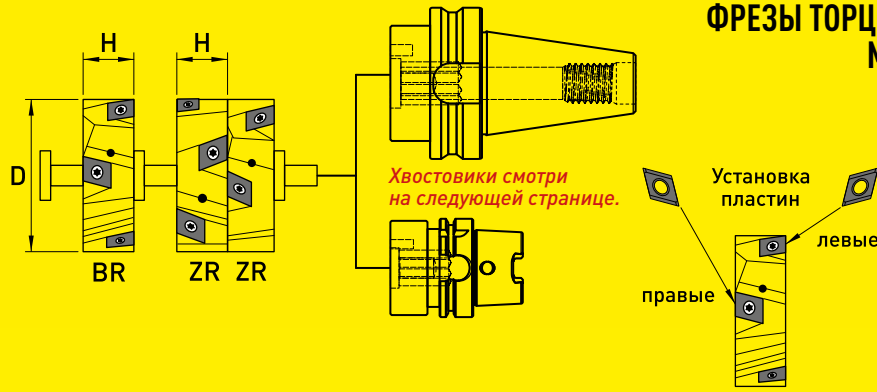

**ФРЕЗЫ ТОРЦОВО-ЦИЛИНДРИЧЕСКИЕ
МОДУЛЬНЫЕ НАСАДНЫЕ**



Модуль BR							
Артикул	D мм	H	Z	Zn	Пластины	Винт	Ключ
SMKB0500-065Z03P09N06C	50	17.1	3	6	SM0500GX-0904...	SDS4090	T15
SMKB0500-066Z03P09N06C	63						
SMKB0500-068Z03P12N06C	80	23.2	4	8	SM0500GX-1206...		
SMKB0500-081Z04P12N08C	100						
Модуль ZR							
SMKZ0500-065Z03P09N06C	50	16.0	3	6	SM0500GX-0904...	SDS5016A	T20
SMKZ0500-066Z03P09N06C	63						
SMKZ0500-068Z03P12N06C	80	22.0	4	8	SM0500GX-1206...		
SMKZ0500-081Z04P12N08C	100						

Модули собираются в пакет в необходимом для заказчика количестве в зависимости от требуемой глубины обработки и закрепляются на хвостовике необходимого стандарта и размера (см. стр. 137).
Каждый модуль имеет внутренний подвод СОЖ и оснащается как левыми так и правыми пластинами.
Модуль BR используется исключительно как торцовый.

ПЛАСТИНЫ ДЛЯ ФРЕЗ: ТИП SMKZ0500.
Мощные пластины с четырьмя режущими кромками.
Изготавливаются как в левом так и в правом исполнении

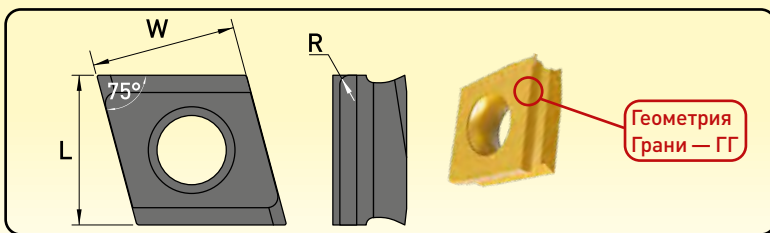

P	★		
M	★		
K		★	
N			★
S			
H			

УРП	Артикул правые/левые	L = W	R	ар мм	fz мм/зуб	С П Л А В Ы				
						с покрытием	без покрытия			
						SPM30	SK74	SN20		
09	SM0500GX-090406 R/L	9.525	0.6	—	0.05-0.13	●	●			
	SM0500GX-090408 R/L		0.8			●	●			
	SM0500GX-090406 R/L AL		0.6					●		
	SM0500GX-090408 R/L AL		0.8					●		
12	SM0500GX-120608 R/L	12.700	0.8			—	0.06-0.15	●	●	
	SM0500GX-120610 R/L		1.0					●	●	
	SM0500GX-120608 R/L AL		0.8							●
	SM0500GX-120610 R/L AL		1.0							●

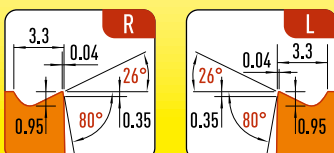

ГГ ГГ

ХВОСТОВИКИ JIS B6339 (MAS 403-BT)



BT 40			
Артикул	D мм	L мм	d мм
BT40AD-SMK25050	58	50	25
BT40AD-SMK25075		75	
BT40AD-SMK25100		100	
BT40AD-SMK32050	75	50	32
BT40AD-SMK32075		75	
BT40AD-SMK32100		100	
BT 50			
BT50AD-SMK25065	58	65	25
BT50AD-SMK25090		90	
BT50AD-SMK25110		110	
BT50AD-SMK32065	75	65	32
BT50AD-SMK32090		90	
BT50AD-SMK32110		110	

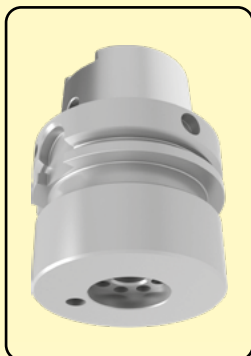
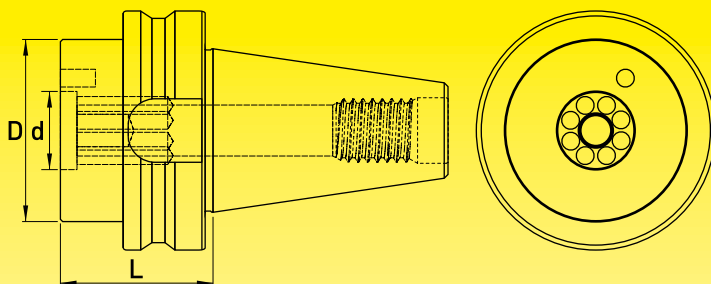

ХВОСТОВИКИ HSK-A DIN 69893 (ISO12164-1)

HSK 63			
Артикул	D мм	L мм	d мм
HSK63A-SMK25070	58	70	25
HSK63A-SMK25110		110	
HSK63A-SMK25130		130	
HSK63A-SMK32070	75	70	32
HSK63A-SMK32110		110	
HSK63A-SMK32130		130	
HSK 100			
HSK100-SMK25070	58	70	25
HSK100-SMK25110		110	
HSK100-SMK25130		130	
HSK100-SMK32070	75	70	32
HSK100-SMK32110		110	
HSK100-SMK32130		130	

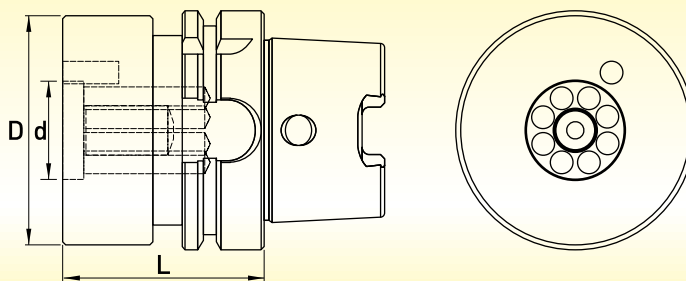

Хвостовики других размеров и стандартов изготавливаются по специальному заказу.



СЕРВИСНЫЙ ЗАВОД

6.2. ФРЕЗЫ ДЛЯ ОБРАБОТКИ ПЛОСКОСТЕЙ

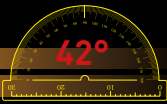

ФРЕЗЫ: ТИП SM421000

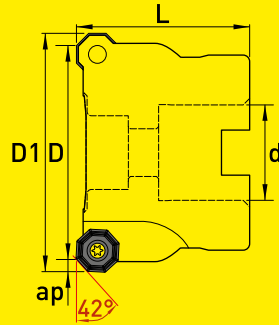

ФРЕЗЫ ТОРЦОВЫЕ НАСАДНЫЕ
(угол в плане 42°) с мощными
8-гранными двусторонними
пластинами (16 режущих кромок).
Крепление винтом



Артикул	D мм	D1 мм	L мм	d мм	T	ap мм	Z	Пластины	Винт	Ключ
SM421000-050Z04040000D22P05	50	56.2	40	22	A	3	4	SM1000GU-0504... SM1000KU-0504...	SDS4090	T15
SM421000-050Z05040000D22P05	50		40	22	A	3	5			
SM421000-050Z06040000D22P05	50		40	22	A	3	6			
SM421000-063Z06040000D22P05	63	69.2	40	22	A	3	6			
SM421000-063Z08040000D22P05	63		40	22	A	3	8			
SM421000-080Z06050000D27P05	80	86.2	50	27	A	3	6			
SM421000-080Z08050000D27P05	80		50	27	A	3	8			
SM421000-080Z09050000D27P05	80		50	27	A	3	9			
SM421000-100Z07050000D32P05	100	106.2	50	32	B	3	7			
SM421000-100Z09050000D32P05	100		50	32	B	3	9			
SM421000-100Z11050000D32P05	100		50	32	B	3	11			
SM421000-125Z07063000D40P05	125	131.2	63	40	B	3	7			
SM421000-125Z09063000D40P05	125			40	B	3	9			
SM421000-125Z12063000D40P05	125			40	B	3	12			

T — тип крепления на оправке

Фрезы с каналами для подвода СОЖ изготавливаются по специальному заказу.

ПЛАСТИНЫ ДЛЯ ФРЕЗ: ТИП SM421000

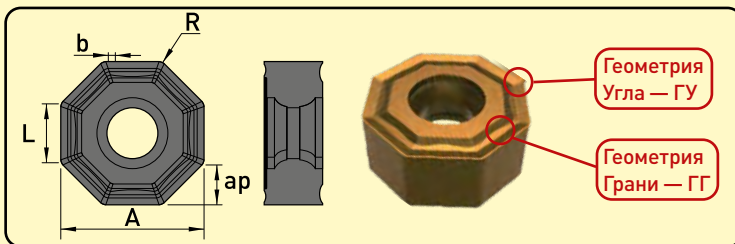

	★	☆	☆	☆
P	★		☆	
M	★		★	
K	☆	★		
N				★
S	☆		☆	
H				

	С	П	Л	А	В	Ы
	с покрытием					без покрытия

УРП	Артикул	A мм	L мм	ap мм	R мм	b мм	ap мм	fz мм/зуб	SU32	SK74	SM83	SN20
05	SM1000GU-050408-M	12.7	4	3	0.8	—	1-3	0.08-0.25	●	●	●	
	SM1000GU-050408-LM					—	1-3	0.05-0.20	●	●	●	●
	SM1000GU-050408-WM*					1.6	1-2	0.08-0.25	●	●	●	
	SM1000GU-050408-WLM*					1.6	1-2	0.05-0.20	●	●	●	●
	SM1000KU-050408-M					—	1-3	0.08-0.25	●	●	●	
	SM1000KU-050408-LM					—	1-3	0.05-0.20	●	●	●	

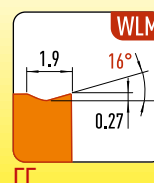
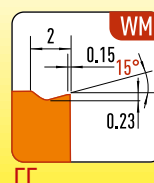
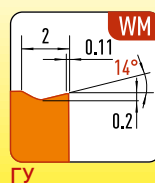
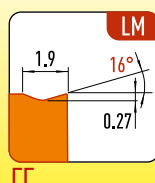
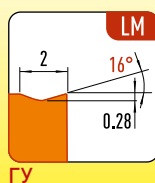
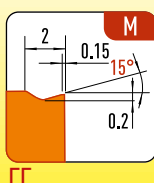
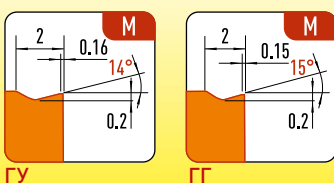

*геометрия «WIPER»

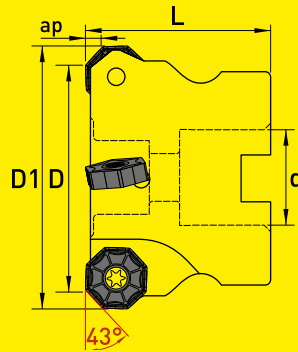

ФРЕЗЫ ТОРЦОВЫЕ НАСАДНЫЕ
(угол в плане 43°)

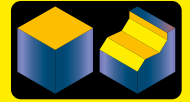

Артикул	D мм	D1 мм	L мм	d мм	T	ap мм	Z	Пластины	Винт	Ключ
SM441000-063Z05050000D22P07	63	75.2	50	22	A	4	5	SM1000KX-0706...	SDS5016A	T20
SM441000-080Z06050000D27P07	80	92.2		27						
SM441000-080Z07050000D27P07										
SM441000-100Z07060000D32P07	100	112.2	60	32	B		7			
SM441000-100Z08060000D32P07							8			
SM441000-125Z08063000D40P07	125	137.2	63	40	C		8			
SM441000-125Z10063000D40P07							10			
SM441000-160Z10063000D40P07	160	172.2					10			
SM441000-160Z12063000D40P07							12			

T — тип крепления на оправке

Фрезы с каналами для подвода СОЖ изготавливаются по специальному заказу.

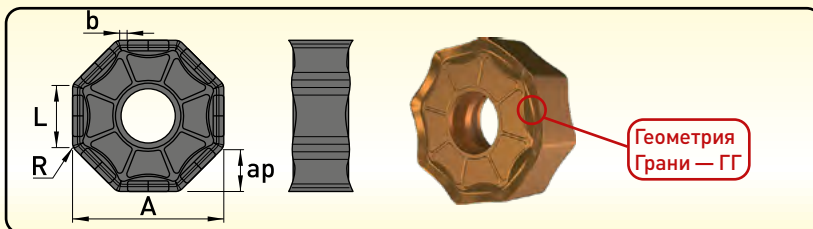

ПЛАСТИНЫ ДЛЯ ФРЕЗ: ТИП SM441000

	★	☆	☆	☆
P	★		☆	☆
M	★		★	★
K	☆	★		
N				
S	☆		☆	★
H				

С П Л А В Ы

с покрытием

УРП	Артикул	A мм	L мм	ap мм	R мм	b мм	ap мм	fz мм/зуб	SU32	SK74	SM83	SMS84
7	SM1000KX-070608-M	19.05	7.9	4	0.8	1.1	1-4	0.1-0.25	●	●	●	●

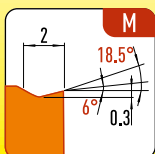

ГГ

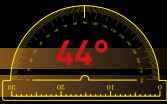

ФРЕЗЫ: ТИП SM441000

ФРЕЗЫ ТОРЦОВЫЕ НАСАДНЫЕ (угол в плане 44°)

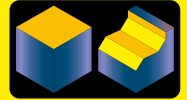
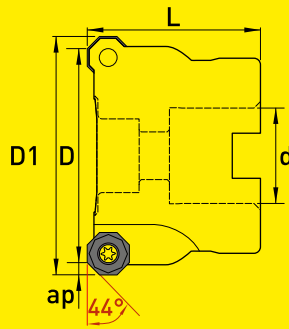
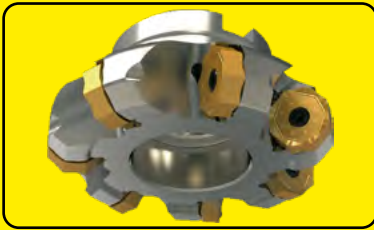

Артикул	D мм	D1 мм	L мм	d мм	T	ap мм	Z	Пластины	Винт	Ключ
SM441000-063Z05040000D22P09	63	78	40	22	A	5	5	SM1000GU-0905...	SDS5016A	T20
SM441000-063Z06040000D22P09							6			
SM441000-080Z06050000D27P09	80	95	50	7						
SM441000-080Z07050000D27P09				8						
SM441000-100Z07050000D32P09	100	115	50	32	B		8			
SM441000-100Z08050000D32P09							10			
SM441000-125Z08063000D40P09	125	140	63	40			C			
SM441000-125Z10063000D40P09					16					
SM441000-160Z10063000D40P09	160	175	63	60	D					
SM441000-160Z12063000D40P09							20			
SM441000-200Z12063000D60P09	200	215	80	60			20			
SM441000-250Z16063000D60P09	250	265	80	60	20					
SM441000-315Z20080000D60P09	315	330	80	60	20					

T — тип крепления на оправке

Фрезы с каналами для подвода СОЖ изготавливаются по специальному заказу.

ПЛАСТИНЫ ДЛЯ ФРЕЗ: ТИП SM441000

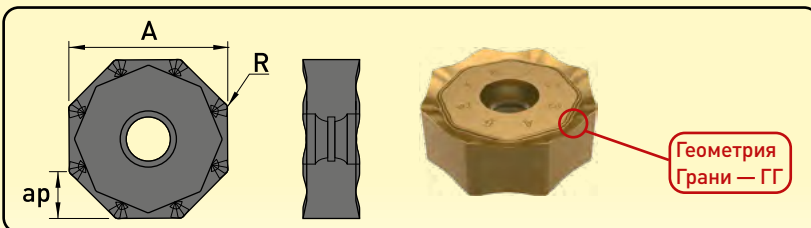

P	★	☆	☆
M	★	★	★
K			
N			
S		☆	★
H			

УРП	Артикул	A мм	ap мм	R мм	ap мм	fz мм/зуб	С П Л А В Ы		
							SPM30	SM83	SMS84
09	SM1000GU-090506-LM	21.85	5	0.6	0.8-5	0.1-0.20	●	●	●
	SM1000GU-090506-WLM*						●	●	●
	SM1000GU-090510-LM			1.0	1.5-5	0.1-0.20	●	●	●
	SM1000GU-090510-WLM*						●	●	●
	SM1000GU-090520-LM						2.0	2.5-5	0.1-0.20

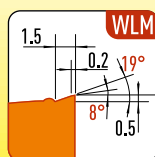
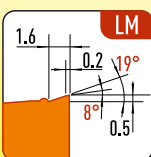

ГГ

ГГ

*геометрия «WIPER»

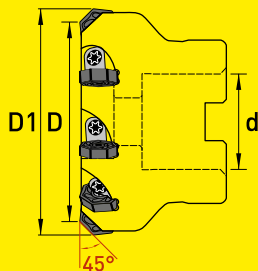

ФРЕЗЫ ТОРЦОВЫЕ НАСАДНЫЕ
(угол в плане 45°)

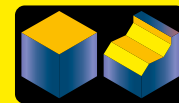

Артикул	D мм	D1 мм	L мм	d мм	T	ap мм	Z	Пластины	Клин	Винт клина	Ключ
SM451800-080Z10050000D27P09W	80	91.9	50	27	A	5.0	10	SM11800KU-0906...	SW8H	SSW8210	KH04
SM451800-100Z13055000D32P09W	100	112.0	63	32	B	5.1	13				
SM451800-125Z17063000D40P09W	125	137.0				5.0	17				
SM451800-160Z18063000D40P09W	160	172.0	63	40	C	5.1	18				
SM451800-160Z21063000D40P09W						5.0	21				
SM451800-200Z26063000D60P09W						5.1	26				
SM451800-250Z34063000D60P09W	250	262.0	63	60	D	5.0	34				
SM451800-315Z42063000D60P09W	315	327.0				5.1	42				

T — тип крепления на оправке

Фрезы с каналами для подвода СОЖ изготавливаются по специальному заказу.

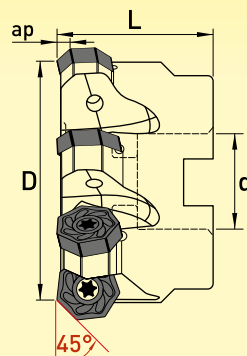
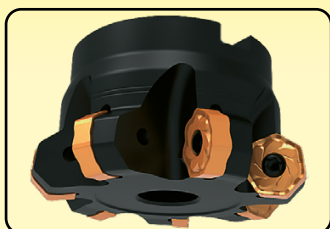

ФРЕЗЫ ТОРЦОВЫЕ НАСАДНЫЕ
(угол в плане 45°)

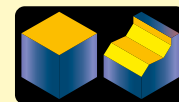

Артикул	D мм	D1 мм	L мм	d мм	T	ap мм	Z	Пластины	Винт	Ключ
SM451800-063Z05050000D22P09	63	74.9	50	22	A	5	5	SM11800KU-0906...	SDS5016A	T20
SM451800-063Z06050000D22P09							6			
SM451800-080Z06050000D27P09	80	91.9	63	27	B	5	6			
SM451800-080Z07050000D27P09							7			
SM451800-100Z07055000D32P09							9			
SM451800-100Z09055000D32P09	100	112.0	63	32	C	5	10			
SM451800-125Z08063000D40P09							8			
SM451800-125Z10063000D40P09							10			
SM451800-125Z12063000D40P09							12			
SM451800-160Z10063000D40P09	160	172.0	63	40	C	5	10			
SM451800-160Z12063000D40P09							12			
SM451800-160Z14063000D40P09							14			
SM451800-200Z12063000D60P09	200	212.0	63	60	C	5	12			
SM451800-200Z16063000D60P09							16			
SM451800-250Z16063000D60P09	250	262.0	63	60	C	5	16			
SM451800-250Z20063000D60P09							20			

T — тип крепления на оправке

Фрезы с каналами для подвода СОЖ изготавливаются по специальному заказу.

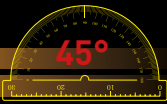

ПЛАСТИНЫ ДЛЯ ФРЕЗ: ТИП SM451800



P	★	☆	☆
M	★	★	★
K			
N			
S		☆	★
H			

С П Л А В Ы

с покрытием

УРП	Артикул	A мм	b мм	R мм	ap мм	fz мм/зуб	SPM30	SM83	SMS84
9	SM1800KU-0906-ANFN-WMM*	18.50	1.0	1.0	1.2-4.0	0.13-0.25	●	●	●

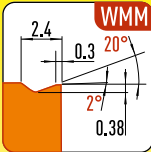

ГГ
*геометрия «WIPER»

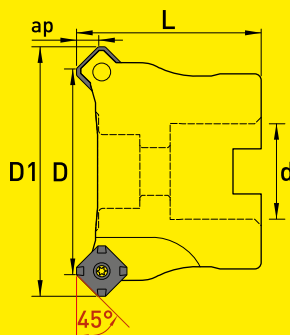

ФРЕЗЫ ТОРЦОВЫЕ НАСАДНЫЕ
(угол в плане 45°)

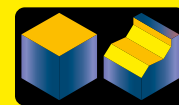

Артикул	D мм	D1 мм	L мм	d мм	T	ap мм	Z	Пластины	Винт	Ключ
SM451320-050Z04040000D22P13T	50	62	40	22	A		4	SM1320KT-13T3... SM132MTD-13T3... SM132KTD-13T3...	SDC3580	T15
SM451320-063Z05040000D22P13T	63	75					5			
SM451320-080Z06050000D27P13T	80	92					6			
SM451320-100Z07050000D32P13T	100	112	50	27	B	6	7			
SM451320-125Z08063000D40P13T	125	137					8			
SM451320-160Z10063000D40P13T	160	172	63	40	C		10			
SM451320-200Z12063000D60P13T	200	212					12			
SM451320-250Z14063000D60P13T	250	262					14			

T — тип крепления на оправке

Фрезы с каналами для подвода СОЖ изготавливаются по специальному заказу.

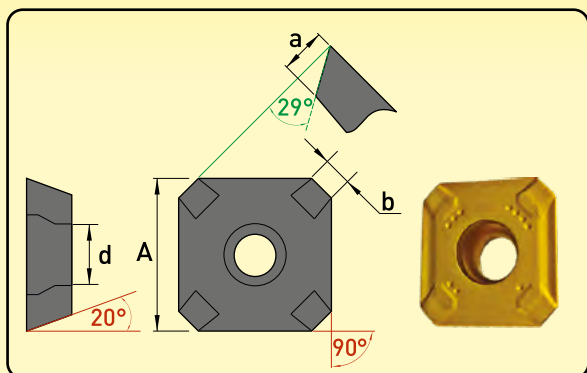

ПЛАСТИНЫ ДЛЯ ФРЕЗ: ТИП SM451320

	★		☆
P	★		☆
M	★		★
K	☆	★	
N			
S	☆		★
H			

С П Л А В Ы
с покрытием

УРП	Артикул	A мм	b мм	d мм	a мм	ap мм	fz мм/зуб	SU32	SK74	SMS84
13	SM1320KT-13T3N-MP	13.4	2.55	4.1	3.97	1.0-5.5	0.08-0.20	●	●	●

ПЛАСТИНЫ ДЛЯ ФРЕЗ: ТИП SM451320 («ИЗ ВОСХОД») И ТИП ASX445 («MITSUBISHI»)

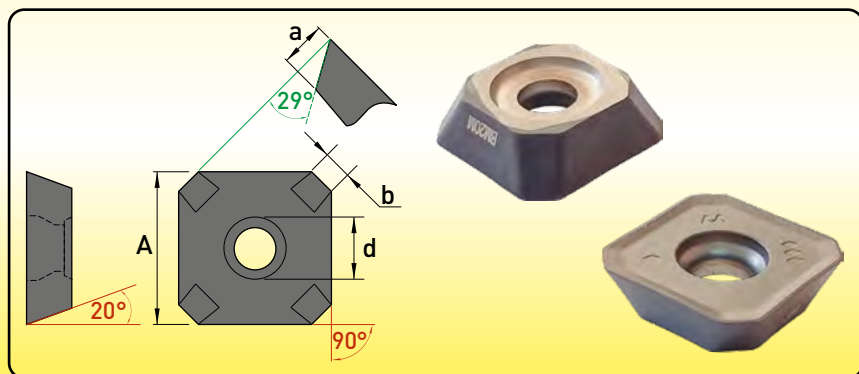

	★	★	
P	★	★	
M		★	
K		★	
N			★
S			
H			

С П Л А В Ы
с покрытием без покрытия

УРП	Артикул	A мм	b мм	d мм	a мм	ap мм	fz мм/зуб	ZP20	BM20M	FN10
13	SM1320MTD-13T3AGSN-GM	13.4	2.55	4.1	3.97		0.3-5.0	0.10-0.30	●	
	0.3-3.0						0.08-0.30		●	
	0.3-5.5						0.10-0.40			●

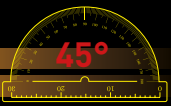

ФРЕЗЫ: ТИП SM451000

ФРЕЗЫ ТОРЦОВЫЕ НАСАДНЫЕ (угол в плане 45°)

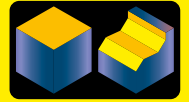
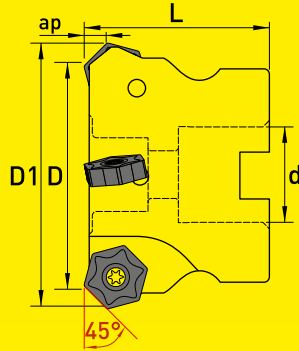

Артикул	D мм	D1 мм	L мм	d мм	T	ap мм	Z	Пластины	Винт	Ключ
SM451000-063Z05050000D22P10	63	77	50	22	A	6.1	5	SM1000KX-1006...	SDS5016A	T20
SM451000-063Z06050000D22P10							6			
SM451000-080Z06055000D27P10	7									
SM451000-080Z07055000D27P10	8									
SM451000-100Z07063000D32P10	9									
SM451000-100Z09063000D32P10	10									
SM451000-125Z08063000D40P10	10									
SM451000-125Z10063000D40P10	12									
SM451000-125Z12063000D40P10	10									
SM451000-160Z10063000D40P10	12									
SM451000-160Z12063000D40P10	14									
SM451000-160Z14063000D40P10	12									
SM451000-200Z12063000D60P10	200	214	63	40	C	6.1	10	SM1000KX-1006...	SDS5016A	T20
SM451000-200Z16063000D60P10							12			
SM451000-250Z16063000D60P10	16									
SM451000-250Z20063000D60P10	20									

T — тип крепления на оправке

Фрезы с каналами для подвода СОЖ изготавливаются по специальному заказу.

ПЛАСТИНЫ ДЛЯ ФРЕЗ: ТИП SM451000

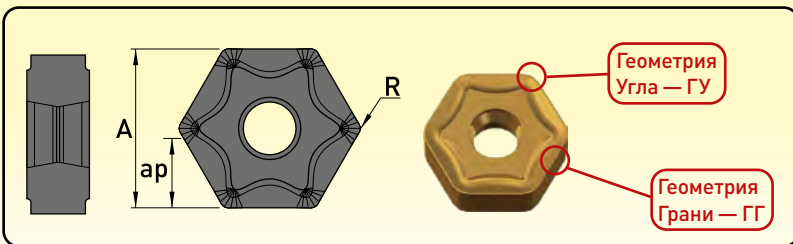

	★	★		
P	★	★		
M	★	★		
K	☆		★	★
N				
S	☆			
H				

С П Л А В Ы
с покрытием

УРП	Артикул	A мм	ap мм	R мм	ap мм	fz мм/зуб	SU32	SPM30	SK72	SK74
10	SM1000KX-1006ANTN-M	19.05	6.1	1.0	1.5-5.0	0.1-0.2	●	●	●	●

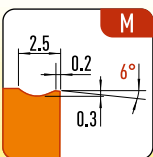

ГУ

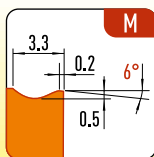

ГГ

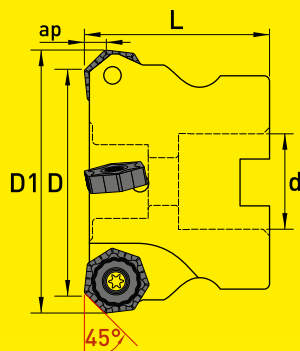
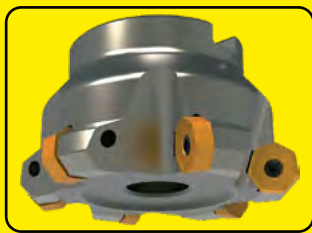

ФРЕЗЫ ТОРЦОВЫЕ НАСАДНЫЕ
(угол в плане 45°) с мощными
7-гранными двусторонними
пластинами (14 режущих кромок).
Крепление винтом

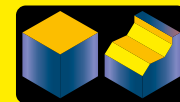

Артикул	D мм	D1 мм	L мм	d мм	T	ap мм	Z	Пластины	Винт	Ключ
SM451800S-040Z03040000D16P07S	40	50	40	16	A	4.0	3	SM1800GX-0705... SM1800KX-0705... SM1800MX-0705...	SDS4013P	T10
SM451800S-050Z04045000D22P07S	50	60	45	22			4			
SM451800S-050Z05045000D22P07S							5			
SM451800S-063Z05045000D22P07S	63	73	50	27			6			
SM451800S-063Z06045000D22P07S							7			
SM451800S-080Z06050000D27P07S	80	90	63	40			B			
SM451800S-080Z07050000D27P07S	100	110			32	10				
SM451800S-100Z07050000D32P07S						9				
SM451800S-100Z08050000D32P07S	125	135	63	40	C	12				
SM451800S-125Z08063000D40P07S						10				
SM451800S-125Z10063000D40P07S	160	170	63	40	C	9				
SM451800S-160Z09063000D40P07S						11				
SM451800S-160Z12063000D40P07S	12									

T — тип крепления на оправке

Фрезы с каналами для подвода СОЖ изготавливаются по специальному заказу.

ПЛАСТИНЫ ДЛЯ ФРЕЗ: ТИП SM451800

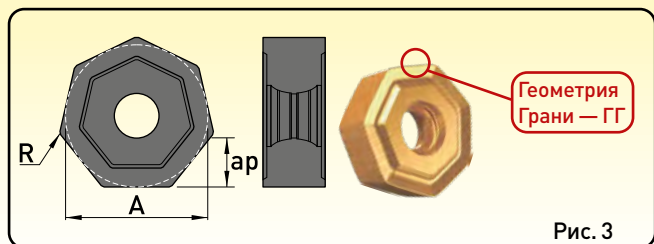
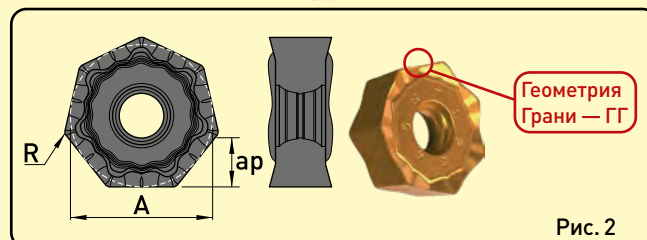
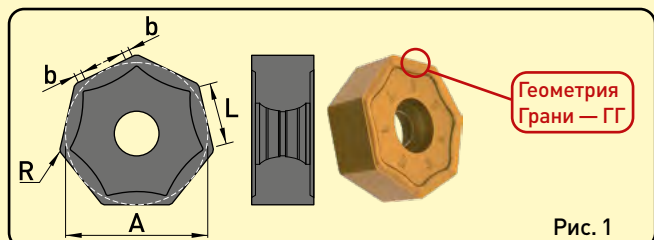

P	★	★			☆	☆
M	★	★			★	★
K	☆		★	★		
N						
S	☆				★	☆
H						

С П Л А В Ы

с покрытием

УРП	Артикул	Рис.	A мм	L мм	ap мм	R мм	b мм	ap мм	fz мм/зуб	SU32	SPM30	SK72	SK74	SMS84	SM83
07	SM1800GX-070508N-M	1	14.5	6.98	—	0.8	—	1-4	0.1-0.2	●	●	●	●	●	
	SM1800GX-070508N-WM*				1.1		1-4	0.1-0.2	●	●	●	●	●		
	SM1800KX-070508N-SM	2		—	1-4	0.1-0.2	●	●	●	●	●				
	SM1800MX-070508-LM			—	1-4	0.1-0.2		●		●	●				
	SM1800MX-070508-WLM*			3	—	1-4	0.1-0.2	●				●			

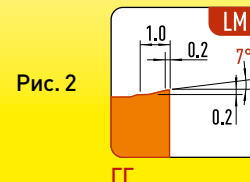
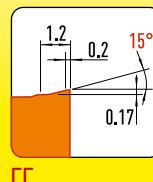
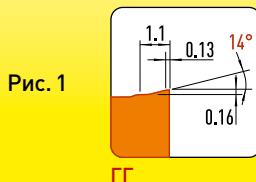

*геометрия «WIPER»

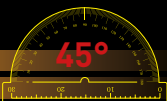

ФРЕЗЫ: ТИП SM451300

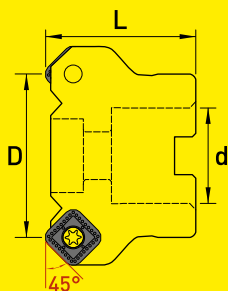

ФРЕЗЫ ТОРЦОВЫЕ НАСАДНЫЕ
 (угол в плане 45°) с мощными 4-гранными двусторонними пластинами (8 режущих кромок).
 Крепление винтом.
 Возможно применение с зачистной пластиной



Артикул	D мм	L мм	d мм	T	ар мм	Z	Пластины	Винт	Ключ
SM451300-050Z03040000D22P12	50	40	22	A	6.0	3	SM1300KX-1206XTN SM1300HX-1206XTN...	SS4010	T15
SM451300-050Z04040000D22P12						4			
SM451300-050Z05040000D22P12						5			
SM451300-063Z04040000D22P12	4								
SM451300-063Z05040000D22P12	5								
SM451300-063Z06040000D22P12	6								
SM451300-080Z05050000D27P12	80	50	27	B		5			
SM451300-080Z06050000D27P12						6			
SM451300-080Z10050000D27P12						10			
SM451300-100Z06050000D32P12	100	40	32			6			
SM451300-100Z08050000D32P12						8			
SM451300-100Z12050000D32P12						12			
SM451300-125Z07063000D40P12	125	63	40	C	7				
SM451300-125Z10063000D40P12					10				
SM451300-125Z16063000D40P12					16				
SM451300-160Z08063000D40P12	160	60	60		8				
SM451300-160Z12063000D40P12					12				
SM451300-160Z20063000D40P12					20				
SM451300-200Z10063000D60P12	200	63	60	D	10				
SM451300-200Z18063000D60P12					18				
SM451300-200Z22063000D60P12					22				
SM451300-250Z12063000D60P12	250	60	60		12				
SM451300-250Z20063000D60P12					20				
SM451300-250Z24063000D60P12					24				
SM451300-315Z15063000D60P12	315	60	60	15					
SM451300-315Z22063000D60P12				22					
SM451300-315Z26063000D60P12				26					
SM451300-063Z04050000D22P17	63	50	22	A	7.8	SM1300KX-1707XTN-M	SDS5016A	T20	
SM451300-080Z05050000D27P17	80		27						
SM451300-100Z07050000D32P17	100		32						
SM451300-125Z08063000D40P17	125	63	40	B					8
SM451300-125Z10063000D40P17									10
SM451300-160Z10063000D40P17									160
SM451300-160Z12063000D40P17	160	60	60	C	12				
SM451300-200Z12063000D60P17					200				
SM451300-250Z14063000D60P17					250				

T — тип крепления на оправке

Фрезы с каналами для подвода СОЖ изготавливаются по специальному заказу.

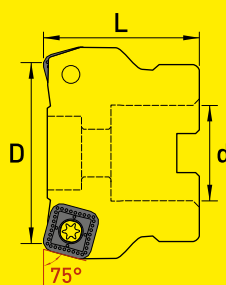

ФРЕЗЫ ТОРЦОВЫЕ НАСАДНЫЕ
(угол в плане 75°)



Артикул	D мм	L мм	d мм	T	ар мм	Z	Пластины	Винт	Ключ
SM751300-050Z03040000D22P12	50	40	22	A	6	3	 SM1300KX-1206XTN SM1300HX-1206XTN... 12	SS4010	T15
SM751300-050Z04040000D22P12						4			
SM751300-050Z05040000D22P12						5			
SM751300-063Z04040000D22P12	63	50	27			4			
SM751300-063Z05040000D22P12						5			
SM751300-063Z06040000D22P12						6			
SM751300-080Z05050000D27P12	80	50	32	5					
SM751300-080Z06050000D27P12				6					
SM751300-080Z10050000D27P12				10					
SM751300-100Z06050000D32P12	100	63	60	B		6			
SM751300-100Z08050000D32P12						8			
SM751300-100Z12050000D32P12						12			
SM751300-125Z07063000D40P12	125	63	60			7			
SM751300-125Z10063000D40P12						10			
SM751300-125Z16063000D40P12						16			
SM751300-160Z08063000D40P12	160	63	60	C		8			
SM751300-160Z12063000D40P12						12			
SM751300-160Z20063000D40P12						20			
SM751300-200Z10063000D60P12	200	63	60			10			
SM751300-200Z18063000D60P12						18			
SM751300-200Z22063000D60P12						22			
SM751300-250Z12063000D60P12	250	63	60	D		12			
SM751300-250Z20063000D60P12						20			
SM751300-250Z24063000D60P12						24			
SM751300-315Z15063000D60P12	315	63	60		15				
SM751300-315Z22063000D60P12					22				
SM751300-315Z26063000D60P12					26				

T — тип крепления на оправке

Фрезы с каналами для подвода СОЖ изготавливаются по специальному заказу.

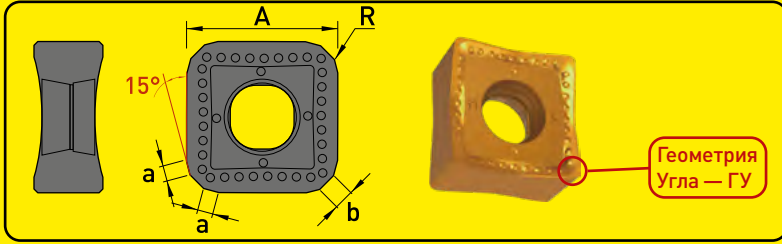
ПЛАСТИНЫ ДЛЯ ФРЕЗ: ТИП SM451300, SM751300

P	★		☆	★	
M	★		★		
K	☆	★		☆	
N					★
S	☆		☆		
H					

С П Л А В Ы

с покрытием без покрытия

УРП	Артикул	A мм	a мм	b мм	R мм	ap max мм	fz мм/зуб	SU32	SK72	SM83B	SPK25	SN20
12	SM1300KX-1206XTN	12.7	1.25	1.3	0.4	6.0/9.0*	0.1-0.2	●	●	●	●	
	SM1300HX-1206XTN-LM					6.0/9.0*	0.1-0.2	●	●	●	●	
	SM1300HX-1206XTN-AL					6.0/9.0*	0.1-0.2					●
17	SM1300KX-1707XTN-M	17.2	1.60	1.5	0.5	7.8 max	0.1-0.2	●				

* — ap max (с углом в плане 45/75°)

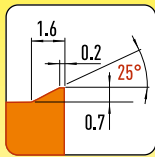

SM1300KX-1206...

ГУ

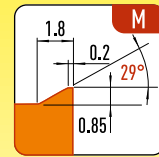

SM1300KX-1707...

ГУ

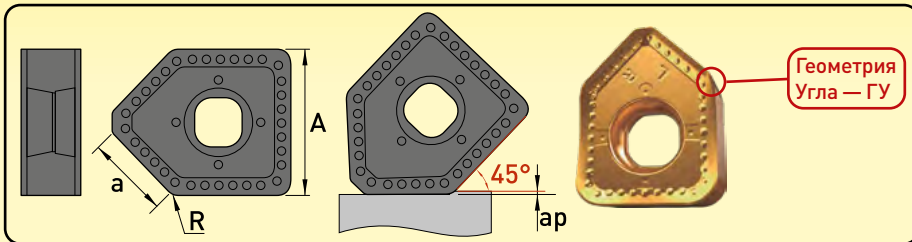
**ДВУСТОРОННИЕ ЗАЧИСТНЫЕ ПЛАСТИНЫ ДЛЯ ФРЕЗ: ТИП SM451300
(только для фрез с углом в плане 45°)**

P	★
M	★
K	★
N	
S	★
H	★

с покрытием

УРП	Артикул	A мм	a мм	R мм	ap мм	fz мм/зуб	SK72
12	SM1300KX-1206ANSN-W	12.7	6.9	0.4	0.03-1.00	0.1-0.2	●

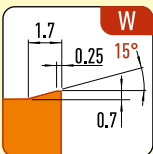

ГУ

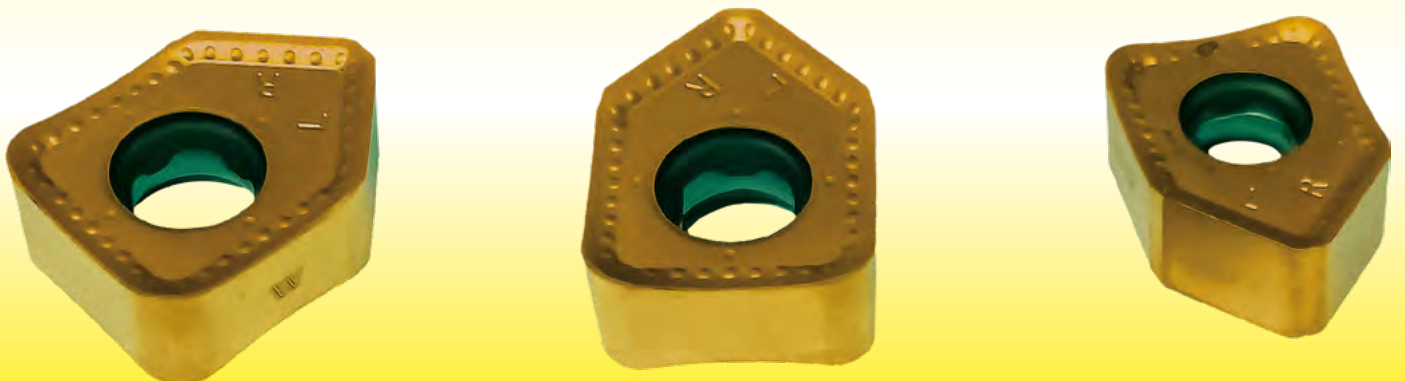

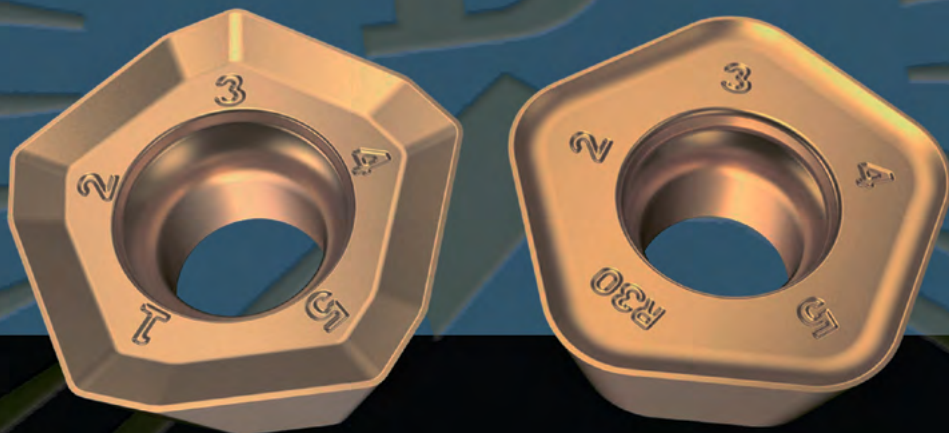

ИНСТРУМЕНТАЛЬНЫЙ ЗАВОД
«ВОСХОД»

6.3. ФРЕЗЫ ДЛЯ ВЫСОКИХ ПОДАЧ

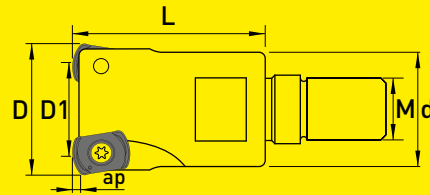
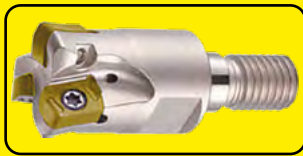

**ГОЛОВКИ ФРЕЗЕРНЫЕ
С РЕЗЬБОВЫМ ХВОСТОВИКОМ
ДЛЯ ВЫСОКИХ ПОДАЧ**



Артикул	D мм	D1 мм	L мм	d мм	ap мм	M	Z	Пластины	Винт	Ключ
SMHFB00-030Z02043000M16P11	30	14.7	43	29	2	16	2	SHFB00MX-1105...	SDD5012	T20
SMHFB00-032Z02043000M16P11	32	16.6								
SMHFB00-033Z02043000M16P11	33	17.6								
SMHFB00-035Z03043000M16P11	35	19.5								
SMHFB00-040Z03043000M16P11	40	24.4								
SMHFB00-042Z03043000M16P11	42	26.4								

Фрезы с каналами для подвода СОЖ изготавливаются по специальному заказу.

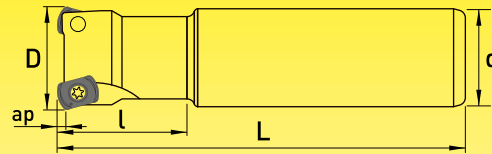

**ФРЕЗЫ КОНЦЕВЫЕ
С ЦИЛИНДРИЧЕСКИМ
ХВОСТОВИКОМ
ДЛЯ ВЫСОКИХ ПОДАЧ**

Артикул	D мм	l мм	L мм	d мм	ap мм	Z	Пластины	Винт	Ключ
SMHFB00-016Z02040150S15P06	16	40	150	15	0.7	2	SHFB00MX-0603...	SDC3080	T10
SMHFB00-016Z02030100S16P06		30	100						
SMHFB00-016Z02040150S16P06	40	150							
SMHFB00-017Z02030100S16P06	17	30	100	16	0.7	2			
SMHFB00-017Z02040150S16P06		40	150						
SMHFB00-017Z02020200S16P06		20	200						
SMHFB00-018Z02025150S16P06	18	25	150	20	0.7	2			
SMHFB00-020Z02080200S20P06	20	80	200						
SMHFB00-020Z03080180S19P06		180	19						
SMHFB00-020Z03050130S20P06		50	130						
SMHFB00-020Z03080160S20P06	20	80	160	20	0.7	3			
SMHFB00-021Z03020150S20P06		150	200						
SMHFB00-021Z03020200S20P06	21	20	200	25	0.7	4			
SMHFB00-025Z03050220S25P06	50	220							
SMHFB00-025Z04060180S24P06	25	180	24	25	0.7	4			
SMHFB00-025Z04060140S25P06		60	140						
SMHFB00-025Z04060180S25P06		180	25						
SMHFB00-025Z04040250S25P06		40	250						
SMHFB00-026Z03030200S25P06	26	200	25	0.7	3				
SMHFB00-026Z03030250S25P06		250							
SMHFB00-026Z04030150S25P06		30				150			
SMHFB00-026Z04030200S25P06		200				25			
SMHFB00-026Z04030250S25P06	250	25							
SMHFB00-030Z04070150S32P06	30	70	150	32	1.0	5			
SMHFB00-030Z05070150S32P06		150	4						
SMHFB00-030Z04120200S32P06		120	200						
SMHFB00-030Z05120200S32P06	30	200	32	1.0	5				
SMHFB00-032Z04070150S32P06		70				150			
SMHFB00-032Z05070150S32P06		150				4			
SMHFB00-032Z05120200S32P06	32	120	200	32	1.0	5			
SMHFB00-033Z04040220S32P06		40	220						
SMHFB00-033Z04050300S32P06	33	50	300	32	1.0	4			
SMHFB00-033Z05030150S32P06		30	150						
SMHFB00-033Z05040200S32P06		200	5						
SMHFB00-033Z05040250S32P06	33	40	250	32	1.0	5			
SMHFB00-035Z04050200S32P06		200	4						
SMHFB00-035Z04050300S32P06	35	300	32	1.0	5				
SMHFB00-035Z05050200S32P06		200							
SMHFB00-035Z05050300S32P06		300							
SMHFB00-040Z05040220S32P06	40	220	32	1.0	6				
SMHFB00-040Z06040150S32P06		150							
SMHFB00-040Z06040220S32P06		220							

Фрезы с каналами для подвода СОЖ изготавливаются по специальному заказу.



Окончание таблицы

Артикул	D мм	L мм	L мм	d мм	ap мм	Z	Пластины	Винт	Ключ						
SMHFB00-025Z02070150S25P09	25	70	150	25		2									
SMHFB00-025Z02100200S25P09		100	200												
SMHFB00-025Z03070150S25P09		70	150												
SMHFB00-025Z03110200S25P09		110	200												
SMHFB00-026Z03030150S25P09	26	30	150			3	HFV00MX-0904...	SDC3581	T15						
SMHFB00-026Z03030220S25P09			220												
SMHFB00-030Z03070160S32P09	30	70	160								1.5				
SMHFB00-030Z03120220S32P09			120												
SMHFB00-032Z03070160S32P09	32	70	160												
SMHFB00-032Z03120220S32P09			120												
SMHFB00-032Z04070160S32P09			70							160					
SMHFB00-032Z04120220S32P09			120							220					
SMHFB00-033Z04030180S32P09	33	30	180			4									
SMHFB00-033Z04030250S32P09										250					
SMHFB00-040Z04040180S32P09	40	40	180									5			
SMHFB00-040Z04040250S32P09															
SMHFB00-040Z05040180S32P09				180											
SMHFB00-040Z05040250S32P09				250											
SMHFB00-030Z02070150S32P11	30	70	150			2									
SMHFB00-032Z02070150S32P11	32		200												
SMHFB00-032Z03070200S32P11										200					
SMHFB00-033Z02040200S32P11			40							250					
SMHFB00-033Z02050250S32P11	33	50	250		2.0	2	SHFB00MX-1105...	SDD5012	T20						
SMHFB00-033Z03050250S32P11															
SMHFB00-035Z03040200S32P11	35	40	200									3			
SMHFB00-040Z03040150S32P11	40		150												
SMHFB00-040Z03040200S32P11			200												

Фрезы с каналами для подвода СОЖ изготавливаются по специальному заказу.

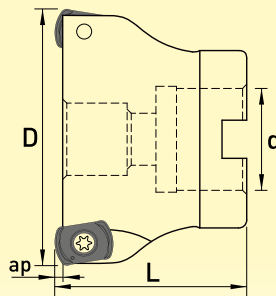

ФРЕЗЫ ТОРЦОВЫЕ НАСАДНЫЕ
ДЛЯ ВЫСОКИХ ПОДАЧ

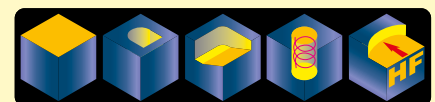

Артикул	D мм	L мм	d мм	T	ap мм	Z	Пластины	Винт	Ключ
SMHFB00-032Z04040000D16P06	32	40	16	A	1.0	4	SHFB00MX-0603...	SDC3080	T10
SMHFB00-032Z05040000D16P06						5			
SMHFB00-040Z06040000D16P06	40		22			6			
SMHFB00-040Z06040000D22P06									
SMHFB00-050Z06040000D22P06	50	50	7						
SMHFB00-050Z06050000D22P06			8						
SMHFB00-050Z07050000D22P06			7						
SMHFB00-052Z07040000D22P06	52	40	7						
SMHFB00-052Z08040000D22P06			8						
SMHFB00-063Z07050000D22P06	63	50	7						
SMHFB00-063Z08050000D22P06			8						
SMHFB00-063Z09050000D22P06			9						
SMHFB00-066Z09050000D27P06	66		27						

T — тип крепления на оправке

Окончание таблицы

Артикул	D мм	L мм	d мм	T	ар мм	Z	Пластины	Винт	Ключ
SMHFB00-040Z04040000D16P09	40	40	16	A	1.5	4	HF00MX-0904...	SDC3581	T15
SMHFB00-040Z05040000D16P09						5			
SMHFB00-050Z05050000D22P09	50	50				6			
SMHFB00-050Z06050000D22P09						7			
SMHFB00-050Z07050000D22P09						6			
SMHFB00-052Z06040000D22P09						7			
SMHFB00-052Z07040000D22P09	52	40	22			6			
SMHFB00-063Z06050000D22P09						7			
SMHFB00-063Z07050000D22P09	63					6			
SMHFB00-063Z08050000D22P09						7			
SMHFB00-066Z07050000D27P09						8			
SMHFB00-066Z08050000D27P09						7			
SMHFB00-080Z07050000D27P09	66	50	27			7			
SMHFB00-080Z08050000D27P09						8			
SMHFB00-080Z09050000D27P09						9			
SMHFB00-080Z10050000D27P09						10			
SMHFB00-100Z08060000D32P09	80					8			
SMHFB00-100Z09060000D32P09						9			
SMHFB00-100Z10060000D32P09						10			
SMHFB00-100Z11060000D32P09						11			
SMHFB00-100Z12060000D32P09	100	60	32	12					
SMHFB00-125Z12060000D40P09				14					
SMHFB00-125Z14060000D40P09				125	40		14		
SMHFB00-040Z04040000D16P11							4		
SMHFB00-050Z04040000D22P11	40	40	16	B	2.0	4	SHFB00MX-1105...	SDD5012	T20
SMHFB00-050Z05040000D22P11						5			
SMHFB00-052Z05040000D22P11	50	50	22			6			
SMHFB00-063Z05050000D22P11						7			
SMHFB00-063Z06050000D22P11						6			
SMHFB00-066Z06050000D22P11						7			
SMHFB00-080Z06060000D27P11	60	60	27			6			
SMHFB00-080Z07060000D27P11						7			
SMHFB00-100Z06060000D32P11	100	32				6			
SMHFB00-100Z07060000D32P11						7			

T — тип крепления на оправке

Фрезы с каналами для подвода СОЖ изготавливаются по специальному заказу.

ПЛАСТИНЫ ДЛЯ ФРЕЗ: ТИП SMHFB00

Мощные двусторонние пластины.

Четыре режущие кромки с высокопозитивной геометрией

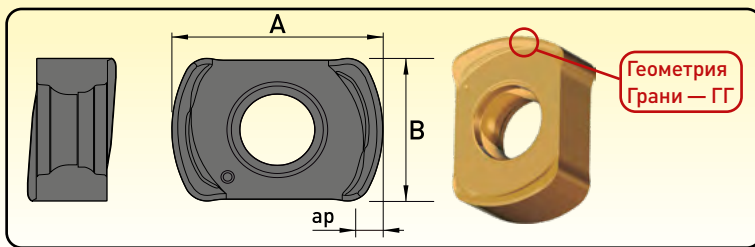

	P	M	K	N	S	H
★	★	★	★	☆	☆	☆
★	★	★	★	☆	☆	☆
☆						
☆					★	★
☆						

С П Л А В Ы
с покрытием

УРП	Артикул	A мм	B мм	ар мм	ар мм	fz мм/зуб	SU32	SPM30	SU52	BS20	ZSP20D
06	SHFB00MX-0603-L	9.0	6,4	1.0	0.1-1.0	0.3-2.5				●	
	SHFB00MX-0603-M						●	●	○		●
	SHFB00MX-0603-MM						●	●	○		
09	SHFB00MX-0904-M	11.9	9	1.5	0.2-1.5	0.3-3.5	●	●	○		
	SHFB00MX-0904-MM						●	●	○		
11	SHFB00MX-1105-LM	14.6	11	2.0	0.3-2.0	0.3-4.0	●	●	○		
	SHFB00MX-1105-M						●	●	○		

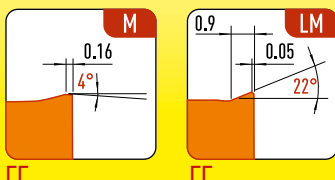

ГГ

ГГ

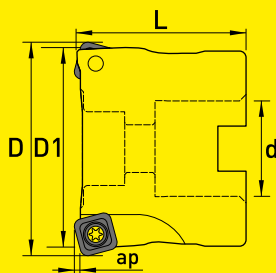

ФРЕЗЫ ТОРЦОВЫЕ НАСАДНЫЕ
ДЛЯ ВЫСОКИХ ПОДАЧ

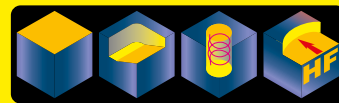

Артикул	D мм	D1 мм	L мм	d мм	T	ap мм	Z	Пластины	Винт	Ключ
SMHFS05-050Z03040000D22P13	50	29.3	40	22	A	2	3	SHFS05MT-1306...	SDD5012	T20
SMHFS05-050Z04040000D22P13							4			
SMHFS05-052Z04040000D22P13	52	31.3	27	5						
SMHFS05-052Z05040000D22P13				4						
SMHFS05-063Z04050000D22P13	63	42.4	50	5						
SMHFS05-063Z05050000D22P13				4						
SMHFS05-063Z04050000D27P13	66	45.3	27	5						
SMHFS05-066Z05050000D27P13				6						
SMHFS05-080Z05060000D27P13	80	59.4	60	5						
SMHFS05-080Z06060000D27P13				6						
SMHFS05-080Z05060000D32P13	100	79.4	32	B	5					
SMHFS05-100Z06060000D32P13					6					

T — тип крепления на оправке

Фрезы с каналами для подвода СОЖ изготавливаются по специальному заказу.

ПЛАСТИНЫ ДЛЯ ФРЕЗ: ТИП SMHFS05.
Мощные односторонние пластины.

Четыре режущие кромки с высокопозитивной геометрией, максимальная глубина резания 2 мм, низкие усилия резания. Позвряет работать на станках с большим вылетом шпинделя и малой мощности. Не оставляет заусенцев на краях заготовки

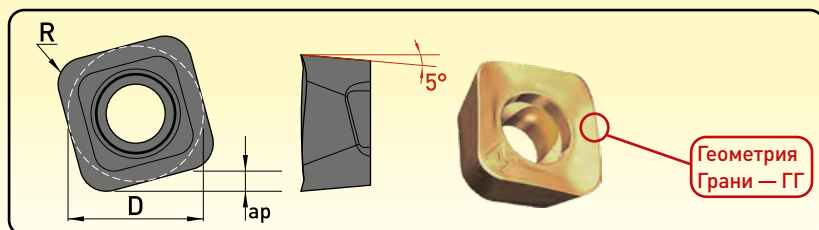

P	★	★		
M	★	★		
K	☆		★	★
N				
S	☆			
H				

С П Л А В Ы

с покрытием

УРП	Артикул	D мм	ap мм	R мм	ap мм	fz мм/зуб	SU32	SPM30	SK72	SK74
13	SHFS05MT-130625-M	13.05	2	2.5	0.5-2.0	0.4-2.5	●	●	●	●

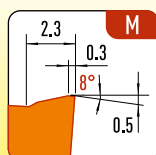

ГГ

6.4. ФРЕЗЫ КАНАВОЧНЫЕ

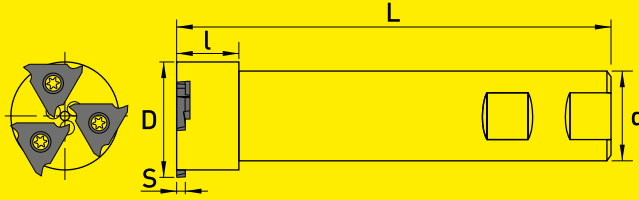
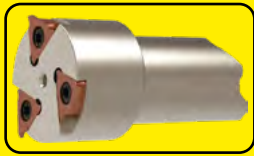

**ФРЕЗЫ КАНАВОЧНЫЕ
С ХВОСТОВИКОМ WELDON.**
Обработка внутренних
и наружных канавок, в том числе
под стопорные кольца



Артикул	D мм	l мм	L мм	d мм	S мм	Z	Пластины	Винт	Ключ
SMGTS R/L-025Z01040125W25P09	25	40	125	25	1.10~3.00	1	GT09S R/L...	SDS4013P	T15
SMGTS R/L-039Z03023125W25P09	39	23				3			
SMGTS R/L-044Z03023125W25P12	44				3	1.25~4.80	GT12S R/L...	SDS5016A	T20

Фрезы с каналами для подвода СОЖ изготавливаются по специальному заказу.

ВНИМАНИЕ! Правосторонние фрезы оснащены левосторонними пластинами,
а левосторонние фрезы — правосторонними пластинами.

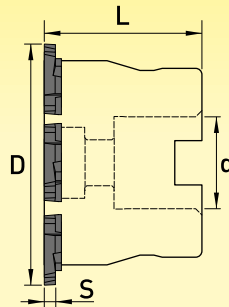
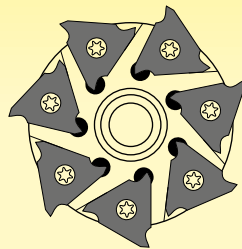
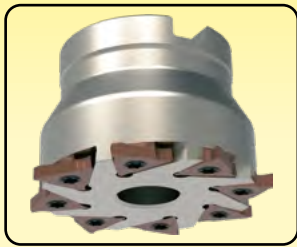

**ФРЕЗЫ КАНАВОЧНЫЕ
НАСАДНЫЕ.**
Обработка внутренних
и наружных канавок, в том числе
под стопорные кольца



Артикул	D мм	L мм	d мм	S мм	T	Z	Пластины	Винт	Ключ
SMGTS R/L-063Z07040000D22P09	63	40	22	1.10~3.00	A	7	GT09S R/L...	SDS4013P	T15
SMGTS R/L-080Z09050000D27P09	80	50	27			9			
SMGTS R/L-100Z11050000D32P09	100	63	40			11			
SMGTS R/L-125Z13063000D40P09	125	63	40	1.25~4.80	B	13	GT12S R/L...	SDS5016A	T20
SMGTS R/L-063Z06040000D22P12	63	40	22			6			
SMGTS R/L-080Z08050000D27P12	80	50	27			8			
SMGTS R/L-100Z10050000D32P12	100	63	40	1.25~4.80	B	10	GT12S R/L...	SDS5016A	T20
SMGTS R/L-125Z12063000D40P12	125	63	40			12			

T — тип крепления на оправке

Фрезы с каналами для подвода СОЖ изготавливаются по специальному заказу.

ВНИМАНИЕ! Правосторонние фрезы оснащены левосторонними пластинами,
а левосторонние фрезы — правосторонними пластинами.

ПЛАСТИНЫ ДЛЯ ФРЕЗ: ТИП SMGTS

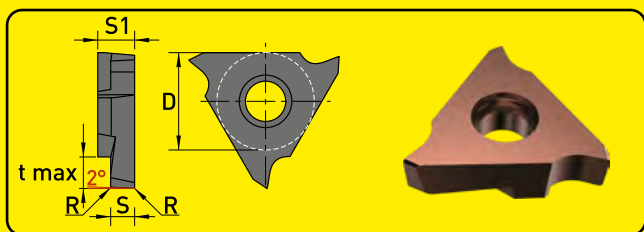

P	★
M	★
K	
N	
S	
H	

СПЛАВЫ
с покрытием

УРП	Артикул	S мм	S1 мм	t max мм	D мм	R мм	ap мм	fz мм/зуб	SU52
09	GT09S R/L 110200R010	1.10	3.18	2.0	9.525	0.1		0.02-0.08	●
	GT09S R/L 125200R020	1.25							●
	GT09S R/L 145200R020	1.45							●
	GT09S R/L 150200R020	1.50		●					
	GT09S R/L 175200R020	1.75		●					
	GT09S R/L 185250R020	1.85		2.5		0.03-0.10		●	
	GT09S R/L 200250R020	2.00						●	
	GT09S R/L 250250R020	2.50						●	
	GT09S R/L 300300R020	3.00		3.0		0.04-0.12		●	
12	GT12S R/L 125200R020	1.25	4.76	2.0	12.700		—	0.02-0.08	●
	GT12S R/L 145200R020	1.45							●
	GT12S R/L 150350R020	1.50							●
	GT12S R/L 175350R020	1.75		3.5				0.03-0.10	●
	GT12S R/L 185350R020	1.85							●
	GT12S R/L 200350R020	2.00							●
	GT12S R/L 230350R020	2.30		4.0				0.04-0.12	●
	GT12S R/L 250400R030	2.50							●
	GT12S R/L 265400R030	2.65							●
	GT12S R/L 280400R030	2.80		5.0				0.05-0.15	●
	GT12S R/L 300400R030	3.00							●
	GT12S R/L 320400R030	3.20							●
	GT12S R/L 330400R030	3.30		0.4				0.05-0.18	●
	GT12S R/L 350500R030	3.50							●
	GT12S R/L 400500R040	4.00							●
	GT12S R/L 430500R040	4.30		5.06					●
	GT12S R/L 450500R040	4.50							●
	GT12S R/L 480500R040	4.80							●

ВНИМАНИЕ! Правосторонние фрезы оснащены левосторонними пластинами, а левосторонние фрезы — правосторонними пластинами.

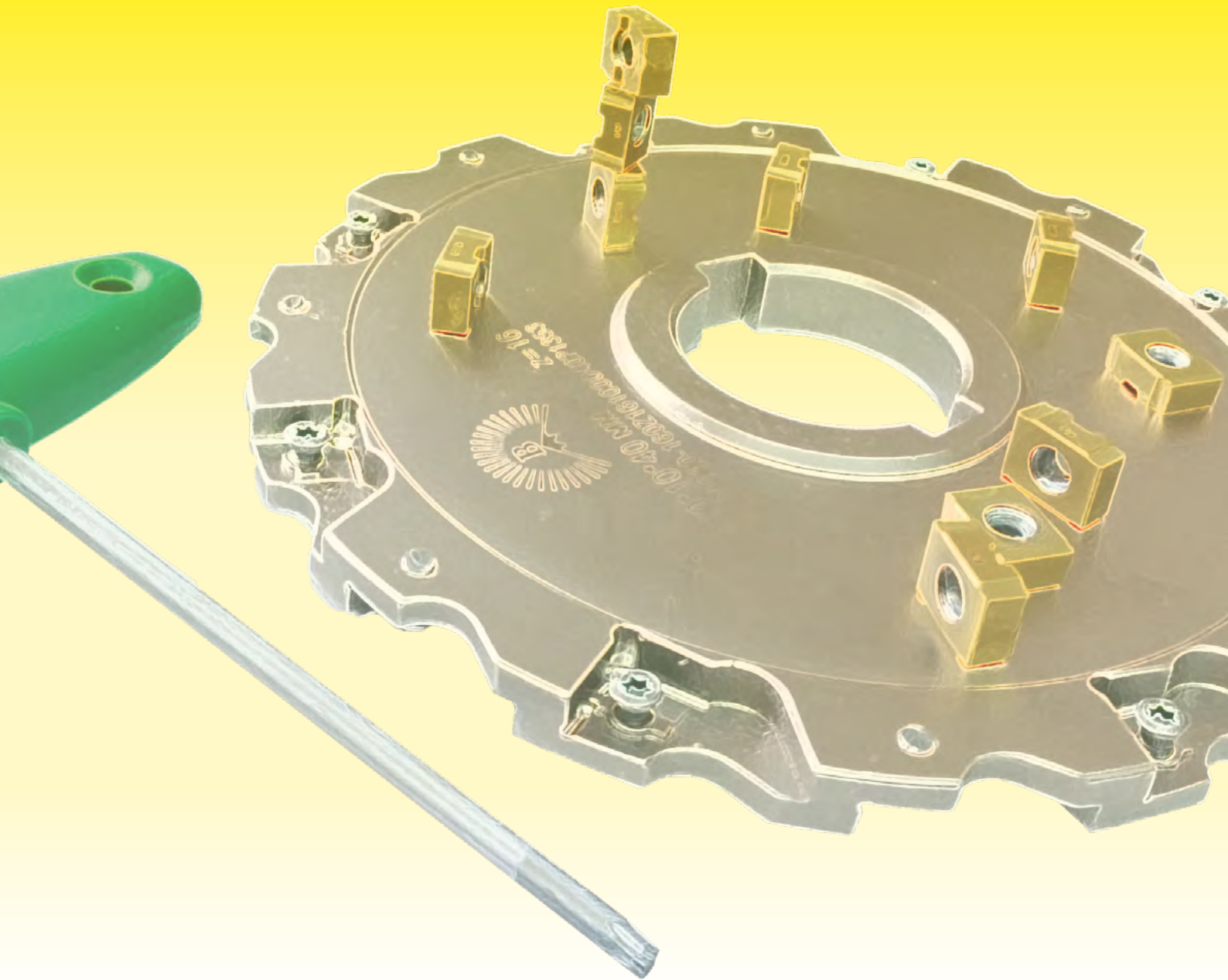

6.5. ФРЕЗЫ ДИСКОВЫЕ

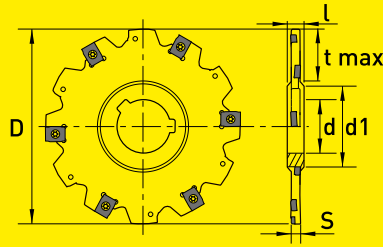

Артикул	D мм	S мм	l мм	d1 мм	d мм	Z	t max	Пластины	Винт	Ключ
SMD1900-063Z08040D22P1023	63	4	8	34	22	4+4	12.0	SM1900HT-1023...	SST02503	T08
SMD1900-080Z10040D22P1023	80					5+5	21.0			
SMD1900-100Z12040D27P1023	100					6+6	27.0			
SMD1900-125Z14040D40P1023	125					7+7	32.0			
SMD1900-063Z08050D22P1028	63	5	8	34	22	4+4	13.0	SM1900HT-1028...	SST02504	T08
SMD1900-080Z10050D22P1028	80					5+5	21.0			
SMD1900-100Z12050D27P1028	100					6+6	27.0			
SMD1900-125Z14050D40P1028	125					7+7	33.0			
SMD1900-160Z18050D40P1028	160	6	12	55	40	9+9	50.0	SM1900HT-1033...	SST02505	T08
SMD1900-063Z08060D22P1033	63					4+4	13.0			
SMD1900-080Z10060D22P1033	80					5+5	21.5			
SMD1900-100Z12060D27P1033	100					6+6	27.0			
SMD1900-125Z14060D40P1033	125	7	8	34	22	7+7	33.0	SM1900HT-1338...	SST04005	T15
SMD1900-160Z18060D40P1033	160					9+9	50.0			
SMD1900-200Z20060D50P1033	200					10+10	63.0			
SMD1900-250Z24060D50P1033	250					12+12	87.5			
SMD1900-080Z08070D22P1338	80	8	12	34	22	4+4	20.0	SM1900HT-1343...	SST04006	T15
SMD1900-100Z10070D27P1338	100					5+5	26.5			
SMD1900-125Z12070D40P1338	125					6+6	32.0			
SMD1900-160Z16070D40P1338	160					8+8	49.5			
SMD1900-200Z88070D50P1338	200	9	12	55	40	9+9	62.5	SM1900HT-1348...	SST04007	T15
SMD1900-250Z24070D50P1338	250					12+12	87.5			
SMD1900-080Z08080D22P1343	80					4+4	20.5			
SMD1900-100Z10080D27P1343	100					5+5	27.0			
SMD1900-125Z12080D40P1343	125	10	12	55	40	6+6	32.5	SM1900HT-1353...	SST04008	T15
SMD1900-160Z16080D40P1343	160					8+8	50.0			
SMD1900-200Z88080D50P1343	200					9+9	63.0			
SMD1900-250Z24080D50P1343	250					12+12	88.0			
SMD1900-100Z10090D27P1348	100	11	16	41	27	5+5	27.5	SM1900HT-1558...	SST05001	T20
SMD1900-125Z12090D40P1348	125					6+6	33.0			
SMD1900-160Z16090D40P1348	160					8+8	50.5			
SMD1900-200Z18090D50P1348	200					9+9	63.5			
SMD1900-250Z24090D50P1348	250	12	16	55	40	12+12	88.5	SM1900HT-1563...	SST05001	T20
SMD1900-100Z10100D27P1353	100					4+4	28.0			
SMD1900-125Z12100D40P1353	125					5+5	33.5			
SMD1900-160Z16100D40P1353	160					7+7	51.0			
SMD1900-200Z18100D50P1353	200	13	16	69	50	8+8	64.0	SM1900HT-1568...	SST05001	T20
SMD1900-250Z24100D50P1353	250					11+11	89.0			
SMD1900-100Z08110D27P1558	100					4+4	28.0			
SMD1900-125Z10110D40P1558	125					5+5	33.5			
SMD1900-160Z14110D40P1558	160	14	16	41	27	7+7	51.0	SM1900HT-1573...	SST05001	T20
SMD1900-200Z16110D50P1558	200					8+8	64.0			
SMD1900-250Z22110D50P1558	250					11+11	89.0			
SMD1900-100Z08120D27P1563	100					4+4	28.0			
SMD1900-125Z10120D40P1563	125	15	16	55	40	5+5	33.5	SM1900HT-1573...	SST05001	T20
SMD1900-160Z14120D40P1563	160					7+7	51.0			
SMD1900-200Z16120D50P1563	200					8+8	64.0			
SMD1900-250Z22120D50P1563	250					11+11	89.0			
SMD1900-100Z08130D27P1568	100	16	16	41	27	4+4	28.0	SM1900HT-1573...	SST05001	T20
SMD1900-125Z10130D40P1568	125					5+5	33.5			
SMD1900-160Z14130D40P1568	160					7+7	51.0			
SMD1900-200Z16130D50P1568	200					8+8	64.0			
SMD1900-250Z22130D50P1568	250	17	16	69	50	11+11	89.0	SM1900HT-1573...	SST05001	T20
SMD1900-100Z08140D27P1573	100					4+4	28.0			
SMD1900-125Z10140D40P1573	125					5+5	33.5			
SMD1900-160Z14140D40P1573	160					7+7	51.0			
SMD1900-200Z16140D50P1573	200	18	16	41	27	8+8	64.0	SM1900HT-1573...	SST05001	T20
SMD1900-250Z22140D50P1573	250					11+11	89.0			

Фрезы с другими размерами изготавливаются по специальному заказу.

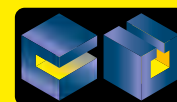
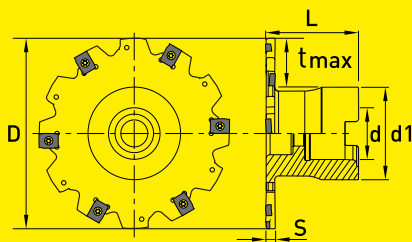
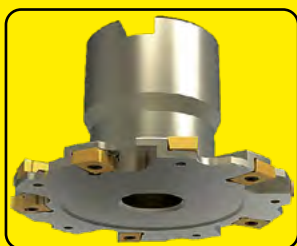

Артикул	D мм	S мм	L мм	d1 мм	d мм	T	Z	t max	Пластины	Винт	Ключ	
SMDH1900-080Z10040D22P1023	80	4	50	40	22	A	5+5	20.0	SM1900HT-1023...	SST02503	T08	
SMDH1900-100Z12040D27P1023	100			48	27		6+6	26.0				
SMDH1900-080Z10050D22P1028	80	5		40	22		A	5+5	20.0	SM1900HT-1028...	SST02504	T08
SMDH1900-100Z12050D27P1028	100			48	27			6+6	26.0			
SMDH1900-080Z10060D22P1033	80	6		40	22	A	5+5	20.0	SM1900HT-1033...	SST02505	T08	
SMDH1900-100Z12060D27P1033	100			48	27		6+6	26.0				
SMDH1900-125Z14060D40P1033	125			70	40	B	7+7	25.0				
SMDH1900-160Z18060D40P1033	160	7		40	22	A	4+4	20.0	SM1900HT-1338...	SST04005	T15	
SMDH1900-080Z08070D22P1338	80			48	27		5+5	25.5				
SMDH1900-100Z10070D27P1338	100			B	70	40	6+6	24.5				
SMDH1900-125Z12070D40P1338	125				8+8	42.0						
SMDH1900-080Z08080D22P1343	80	8		40	22	A	4+4	20.0	SM1900HT-1343...	SST04006	T15	
SMDH1900-100Z10080D27P1343	100			48	27		5+5	25.5				
SMDH1900-125Z12080D40P1343	125			B	70	40	6+6	24.5				
SMDH1900-160Z16080D40P1343	160		8+8		42.0							
SMDH1900-100Z10090D27P1348	100	9	48	27	A	5+5	26.0	SM1900HT-1348...	SST04007	T15		
SMDH1900-125Z12090D40P1348	125		70	40	B	6+6	24.5					
SMDH1900-160Z16090D40P1348	160	10	48	27	A	5+5	26.0	SM1900HT-1353...	SST04008	T15		
SMDH1900-100Z10100D27P1353	100		B	70		40	6+6				24.5	
SMDH1900-125Z12100D40P1353	125			8+8	42.0							
SMDH1900-160Z16100D40P1353	160		48		27	A	4+4				26.0	SM1900HT-1558...
SMDH1900-100Z08110D27P1558	100	11	70	40	B	5+5	24.5					
SMDH1900-125Z10110D40P1558	125		7+7	42.0								
SMDH1900-160Z14110D40P1558	160	48		27	A	4+4	26.0	SM1900HT-1563...	SST05001	T20		
SMDH1900-100Z08120D27P1563	100	12	70	40	B	5+5	24.5					
SMDH1900-125Z10120D40P1563	125		7+7	42.0								
SMDH1900-160Z14120D40P1563	160	48		27	A	4+4	26.0	SM1900HT-1568...	SST05001	T20		
SMDH1900-100Z08130D27P1568	100	13	70	40	B	5+5	24.5					
SMDH1900-125Z10130D40P1568	125		7+7	42.0								
SMDH1900-160Z14130D40P1568	160	48		27	A	4+4	26.0	SM1900HT-1573...	SST05001	T20		
SMDH1900-100Z08140D27P1573	100	14	70	40	B	5+5	24.5					
SMDH1900-125Z10140D40P1573	125		7+7	42.0								
SMDH1900-160Z14140D40P1573	160	48		27	A	4+4	26.0					

Фрезы с другими размерами изготавливаются по специальному заказу.

T — тип крепления на оправке



ПЛАСТИНЫ ДЛЯ ФРЕЗ: ТИП SMD1900, SMDH1900

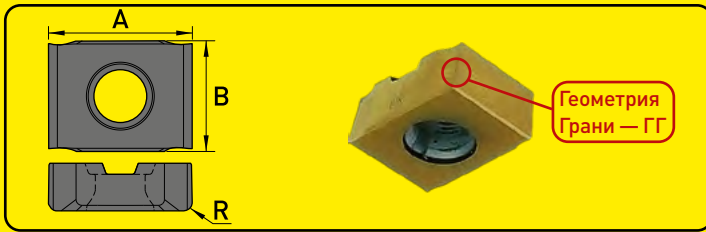

P	★	
M	★	
K	☆	
N	☆	★
S	☆	
H	☆	

С П Л А В Ы	
с покрытием	без покрытия

УРП	Артикул	А мм	В мм	Р мм	S мм	fz мм/зуб	SU32	SN20
10	SM1900HT-101804-LM	10	7.5	0.4	3	0.05-0.08	⊙	○
	SM1900HT-102304-LM	10	7.5	0.4	4	0.05-0.08	⊙	○
	SM1900HT-102804-LM	10	7.5	0.4	5	0.05-0.10	⊙	○
	SM1900HT-103304-LM	10	7.5	0.4	6	0.05-0.12	⊙	○
13	SM1900HT-133804-LM	13	10	0.4	7	0.05-0.12	⊙	○
	SM1900HT-134304-LM	13	10	0.4	8	0.05-0.15	⊙	○
	SM1900HT-134308-LM	13	10	0.8	8	0.05-0.15	⊙	○
	SM1900HT-134804-LM	13	10	0.4	9	0.05-0.15	⊙	○
	SM1900HT-134808-LM	13	10	0.8	9	0.05-0.15	⊙	○
	SM1900HT-135304-LM	13	10	0.4	10	0.05-0.15	⊙	○
	SM1900HT-135308-LM	13	10	0.8	10	0.05-0.15	⊙	○
15	SM1900HT-155804-LM	15	12	0.4	11	0.05-0.15	⊙	○
	SM1900HT-155808-LM	15	12	0.8	11	0.05-0.15	⊙	○
	SM1900HT-156304-LM	15	12	0.4	12	0.05-0.15	⊙	○
	SM1900HT-156308-LM	15	12	0.8	12	0.05-0.15	⊙	○
	SM1900HT-156808-LM	15	12	0.8	13	0.05-0.15	⊙	○
	SM1900HT-156812-LM	15	12	1.2	13	0.05-0.15	⊙	○
	SM1900HT-157308-LM	15	12	0.8	14	0.05-0.15	⊙	○
SM1900HT-157312-LM	15	12	1.2	14	0.05-0.15	⊙	○	

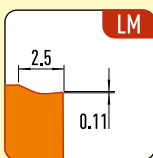

GG

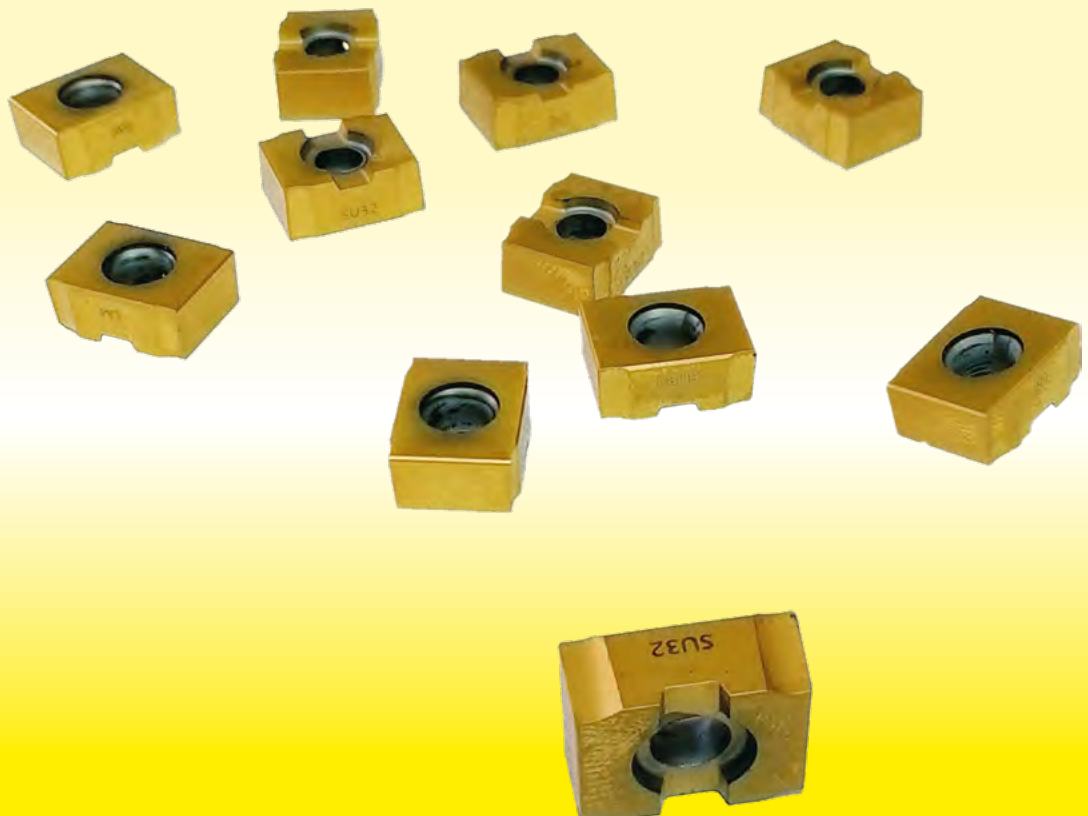

ФРЕЗЫ ДИСКОВЫЕ

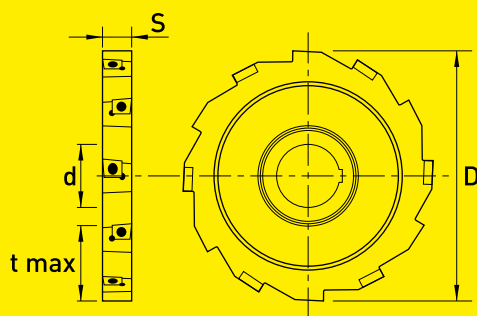

Артикул	D мм	S мм	d мм	Z	t max	Пластины	Винт	Ключ
SMD0300-063Z06150D22P10	63	15	22	6	15	10 SM0300HX-1005...	SDS4013P	T15
SMD0300-080Z08150D22P10	80	15	22	8	24			
SMD0300-100Z10150D27P10	100	15	27	10	30			
SMD0300-125Z12150D32P10	125	15	32	12	40			
SMD0300-160Z14150D40P10	160	15	40	14	52			
SMD0300-200Z16150D50P10	200	15	50	16	65			
SMD0300-250Z18150D60P10	250	15	60	18	80			
SMD0300-063Z06200D22P13	63	20	22	6	15	13 SM0300HX-1305...	SDS4013P	T15
SMD0300-080Z08200D22P13	80	20	22	8	24			
SMD0300-100Z10200D27P13	100	20	27	10	30			
SMD0300-125Z12200D32P13	125	20	32	12	40			
SMD0300-160Z14200D40P13	160	20	40	14	52			
SMD0300-200Z16200D50P13	200	20	50	16	65			
SMD0300-250Z18200D60P13	250	20	60	18	80			
SMD0300-063Z06250D22P16	63	25	22	6	15	16 SM0300HX-1606...	SDS5016A	T20
SMD0300-080Z08250D22P16	80	25	22	8	24			
SMD0300-100Z10250D27P16	100	25	27	10	30			
SMD0300-125Z12250D32P16	125	25	32	12	40			
SMD0300-160Z14250D40P16	160	25	40	14	52			
SMD0300-200Z16250D50P16	200	25	50	16	65			
SMD0300-250Z18250D60P16	250	25	60	18	80			

Возможно изготовление фрез дисковых в диапазоне S = 14÷30 мм, D = 63÷700 мм по специальному заказу.

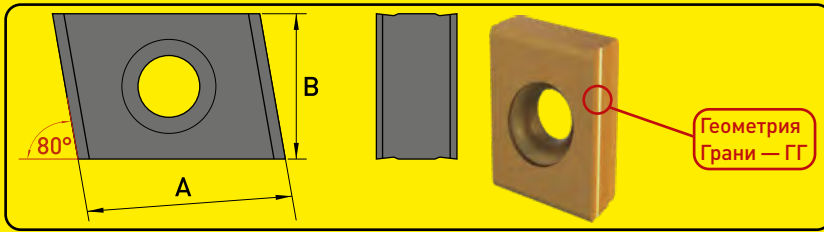
ПЛАСТИНЫ ДЛЯ ФРЕЗ: ТИП SMD0300

P	★	★			
M	★	★			
K	☆		★	★	
N					★
S	☆				
H					

УРП	Артикул	А мм	В мм	R мм	S мм	fz мм/зуб	С П Л А В Ы				
							с покрытием				без покрытия
							SU32	SPM30	SK72	SK74	SN20
10	SM0300HX-100504-LM	10.0	10	0.4	15	0.1-0.30	○	○	○	○	○
	SM0300HX-100508-LM	10.0	10	0.8	15	0.1-0.30	○	○	○	○	○
	SM0300HX-100512-LM	10.0	10	1.2	15	0.1-0.30	○	○	○	○	○
	SM0300HX-100516-LM	10.0	10	1.6	15	0.1-0.30	○	○	○	○	○
13	SM0300HX-130504-LM	12.7	11	0.4	20	0.1-0.35	○	○	○	○	○
	SM0300HX-130508-LM	12.7	11	0.8	20	0.1-0.35	○	○	○	○	○
	SM0300HX-130512-LM	12.7	11	1.2	20	0.1-0.35	○	○	○	○	○
	SM0300HX-130516-LM	12.7	11	1.6	20	0.1-0.35	○	○	○	○	○
	SM0300HX-130520-LM	12.7	11	2.0	20	0.1-0.35	○	○	○	○	○
	SM0300HX-130524-LM	12.7	11	2.4	20	0.1-0.35	○	○	○	○	○
	SM0300HX-130530-LM	12.7	11	3.0	20	0.1-0.35	○	○	○	○	○
16	SM0300HX-160604-LM	16.0	12	0.4	25	0.1-0.40	○	○	○	○	○
	SM0300HX-160608-LM	16.0	12	0.8	25	0.1-0.40	○	○	○	○	○
	SM0300HX-160612-LM	16.0	12	1.2	25	0.1-0.40	○	○	○	○	○
	SM0300HX-160616-LM	16.0	12	1.6	25	0.1-0.40	○	○	○	○	○
	SM0300HX-160624-LM	16.0	12	2.4	25	0.1-0.40	○	○	○	○	○
	SM0300HX-160630-LM	16.0	12	3.0	25	0.1-0.40	○	○	○	○	○

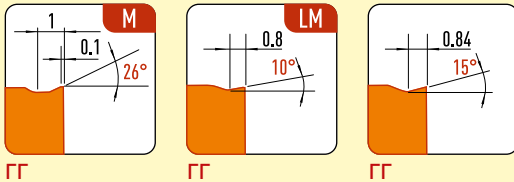

ФРЕЗЫ

РЕЗЬБОНАРЕЗНЫЕ

СО СМЕННЫМИ ПЛАСТИНАМИ



РАЗДЕЛ 7

РЕЗЬБОНАРЕЗНЫЕ ФРЕЗЫ С ОДНОЙ ПЛАСТИНОЙ



рис.1



рис.2

Артикул	Рисунок	D мм	d мм	l мм	l1 мм	L мм	Размер пластины	Винт	Ключ
TMA-012Z01020075W20P14	2	12	20	14	20	75	14	M 3x7.5	T08
TMA-012Z01065120S08P14	1	12	8	14	65	120	14	M 3x7.5	T08
TMA-014Z01065120S10P14	1	14	10	14	65	120	14	M 3x7.5	T08
TMA-015Z01020075W20P14	2	15	20	14	20	75	14	M 3x7.5	T08
TMA-015Z01030085W20P14	2	15	20	14	30	85	14	M 3x7.5	T08
TMA-016Z01065120S12P14	1	16	12	14	65	120	14	M 3x7.5	T08
TMA-017Z01030085W20P14	2	17	20	14	30	85	14	M 3x7.5	T08
TMA-020Z01025085W20P21	2	20	20	21	25	85	21	M 3.5x8	T15
TMA-020Z01040093W20P21	2	20	20	21	40	93	21	M 3.5x8	T15
TMA-023Z01045096W20P21	2	23	20	21	45	96	21	M 3.5x8	T15
TMA-029Z01050108W25P30	2	29	25	30	50	108	30	M 4x0.5x11	T20
TMA-039Z01070130W32P30	2	39	32	30	70	130	30	M 4x0.5x11	T20
TMA-038Z01078140W32P40	2	38	32	40	78	140	40	M 4x0.5x11	T20
TMA-048Z01078153W40P40	2	48	40	40	78	153	40	M 5x11	T20

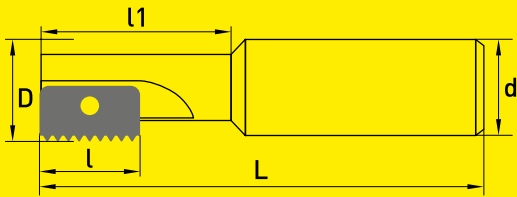
РЕЗЬБОНАРЕЗНЫЕ ФРЕЗЫ С ДВУМЯ ПЛАСТИНАМИ

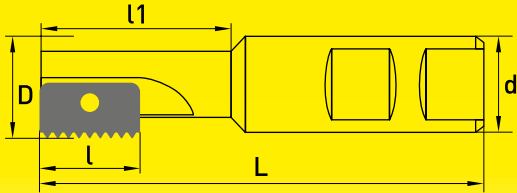
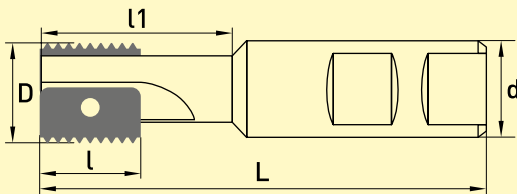

Артикул	D мм	d мм	l мм	l1 мм	L мм	Размер пластины	Винт	Ключ
TMA-020Z02040093W20P14	20	20	14	40	93	14	M 3x8	T08
TMA-030Z02050108W25P21	30	25	21	50	108	21	M 3.5x12	T15
TMA-040Z02070130W32P30	40	32	30	70	130	30	M 4x12	T20
TMA-040Z02105165W32P30	40	32	30	105	165	30	M 4x12	T20
TMA-050Z02083153W40P40	50	40	40	83	153	40	M 5x12	T20
TMA-050Z02115185W40P40	50	40	40	115	185	40	M 5x12	T20

НАСАДНЫЕ РЕЗЬБОНАРЕЗНЫЕ ФРЕЗЫ СО СМЕННЫМИ ПЛАСТИНАМИ

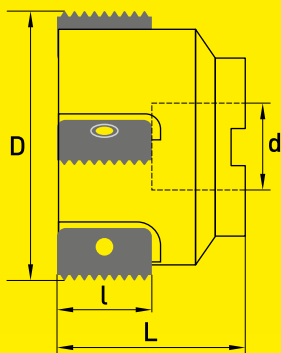

Артикул	D мм	d мм	l мм	L мм	Размер пластины	Количество пластин	Винт	Ключ
TMA-063Z05021050D22P21	63	22	21	50	21	5	M 3.5x7.5	T15
TMA-063Z04030050D22P30	63	22	30	50	30	4	M 4x1x11	T20
TMA-080Z04030055D27P30	80	27	30	55	30	4	M 4x1x11	T20
TMA-100Z04030060D32P30	100	32	30	60	30	4	M 4x1x11	T20
TMA-080Z04040065D27P40	80	27	40	65	40	4	M 4x1x11	T20
TMA-100Z04040070D32P40	100	32	40	70	40	4	M 4x1x11	T20

ПЛАСТИНЫ ДЛЯ ВНЕШНЕЙ РЕЗЬБЫ

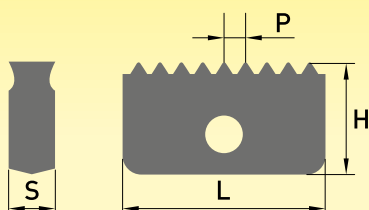

Артикул	L мм	S мм	H мм	Размер пластины	Шаг резьбы P
TMAE14 0.75 ISO	14	3.1	7.5	14	0.75
TMAE14 1.0 ISO	14	3.1	7.5	14	1.00
TMAE14 1.0 ISO	14	3.1	7.5	14	1.25
TMAE14 1.5 ISO	14	3.1	7.5	14	1.50
TMAE14 1.75 ISO	14	3.1	7.5	14	1.75
TMAE14 2.0 ISO	14	3.1	7.5	14	2.00
TMAE14 2.5 ISO	14	3.1	7.5	14	2.50
TMAE21 1.0 ISO	21	4.7	12	21	1.00
TMAE21 1.5 ISO	21	4.7	12	21	1.50
TMAE21 2.0 ISO	21	4.7	12	21	2.00
TMAE21 2.5 ISO	21	4.7	12	21	2.50
TMAE21 3.0 ISO	21	4.7	12	21	3.00
TMAE30 1.5 ISO	30	5.5	16	30	1.50
TMAE30 2.0 ISO	30	5.5	16	30	2.00
TMAE30 3.0 ISO	30	5.5	16	30	3.00
TMAE21 3.5 ISO	30	5.5	16	30	3.50
TMAE21 4.0 ISO	30	5.5	16	30	4.00
TMAE40 1.5 ISO	40	6.3	20.0	40	1.50
TMAE40 2.0 ISO	40	6.3	20.0	40	2.00
TMAE40 3.0 ISO	40	6.3	20.0	40	3.00
TMAE40 4.0 ISO	40	6.3	20.0	40	4.00
TMAE40 5.0 ISO	40	6.3	20.0	40	5.00
TMAE40 6.0 ISO	40	6.3	20.0	40	6.00

ПЛАСТИНЫ ДЛЯ ВНУТРЕННЕЙ РЕЗЬБЫ

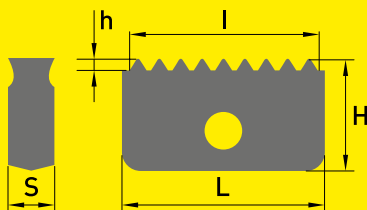

Артикул	l мм	L мм	S мм	H мм	h мм	Размер пластины	Количество режущих кромок	Шаг резьбы
TMAN14 1.0 ISO	14.0	14	3.1	7.5	0.58	14	2	1.0
TMAN14 1.5 ISO	13.5	14	3.1	7.5	0.88	14	2	1.5
TMAN14 2.0 ISO	14.0	14	3.1	7.5	1.17	14	2	2.0
TMAN14 2.5 ISO	12.5	14	3.1	7.5	1.46	14	2	2.5
TMAN21 1.0 ISO	21.0	21	4.7	12.0	0.58	21	2	1.0
TMAN21 1.5 ISO	21.0	21	4.7	12.0	0.88	21	2	1.5
TMAN21 2.0 ISO	20.0	21	4.7	12.0	1.17	21	2	2.0
TMAN21 3.0 ISO	21.0	21	4.7	12.0	1.75	21	2	3.0
TMAN21 3.5 ISO	21.0	21	4.7	12.0	2.05	21	2	3.5
TMAN30 1.5 ISO	30.0	30	5.5	16.0	0.88	30	2	1.5
TMAN30 2.0 ISO	30.0	30	5.5	16.0	1.17	30	2	2.0
TMAN30 3.0 ISO	30.0	30	5.5	16.0	1.75	30	2	3.0
TMAN30 4.0 ISO	28.0	30	5.5	16.0	2.34	30	2	4.0
TMAN30 4.5 ISO	27.0	30	5.5	16.0	2.63	30	2	4.5
TMAN30 5.0 ISO	30.0	30	5.5	16.0	2.92	30	1	5.0
TMAN40 2.0 ISO	40.0	40	6.3	20.0	1.17	40	2	2.0
TMAN40 3.0 ISO	39.0	40	6.3	20.0	1.75	40	2	3.0
TMAN40 4.0 ISO	40.0	40	6.3	20.0	2.34	40	2	4.0
TMAN40 5.0 ISO	40.0	40	6.3	20.0	2.92	40	2	5.0
TMAN40 6.0 ISO	36.0	40	6.3	20.0	3.50	40	2	6.0

РЕЗЬБОНАРЕЗНЫЕ ФРЕЗЫ С ТОРЦОВЫМ КРЕПЛЕНИЕМ ПЛАСТИН С ХВОСТОВИКОМ «WELDON»

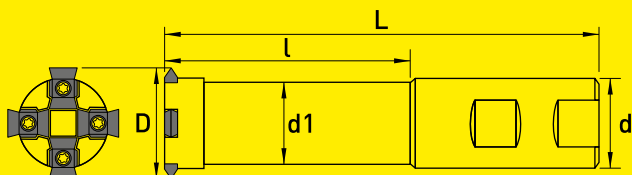

Артикул	min	D мм	d1 мм	l мм	L мм	d мм	Pмм	Z	Пластины	Винт	Ключ
TMC-020Z03065115B16P07	24	20.50	15.9	65	115	16	1.5-3.0	3	TMCN070...	M2.5x6-60°	T08
TMC-023Z03090152B32P09	30	23.85	19.3	90	152	32	1.5-2.5 2.5-4.0	3	TMCN095...	M2.5x6-60°	T08
TMC-029Z03095157B32P09	36	29.50	24.6	95	157	32	1.5-2.5 2.5-4.0	3	TMCN095...		
TMC-032Z05095159B32P09	40	32.85	27.7	95	159	32	1.5-2.5 2.5-4.0	5	TMCN095...		
TMC-032Z03115177B32P13	40	32.85	24.7	115	177	32	1.5-2.5 2.5-5.5	3	TMCN135...	M3.0x8-60°	T08
TMC-040Z05110172B32P13	48	40.25	31.9	110	172	32	1.5-2.5 2.5-5.5	5	TMCN135...		
TMC-040Z04147210B32P15	48	40.25	30.3	147	210	32	1.5-3.0 3.0-6.0	4	TMCN155...	M4.0x13-60°	T15

РЕЗЬБОНАРЕЗНЫЕ ФРЕЗЫ С ТОРЦОВЫМ КРЕПЛЕНИЕМ ПЛАСТИН С ХВОСТОВИКОМ mas 403 BT50

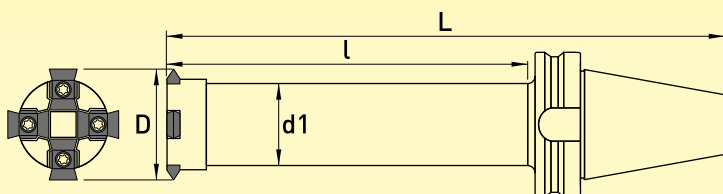

Артикул	min	D мм	d1 мм	l мм	L мм	Pмм	Z	Пластины	Винт	Ключ
TMC-040Z04145295BT50P15	48	40.25	30.3	145	295	1.5-3.0	4	TMCN15...	M4x13-60°	T15
						3.0-6.0		TMCN15...		
TMC-052Z06195345BT50P15	64	52.55	43.7	195	345	1.5-3.0	6	TMCN15...	M4x13-60°	T15
						3.0-6.0		TMCN15...		
TMC-066Z07260410BT50P19	80	66.55	55.3	260	410	1.5-3.0	7	TMCN19...	M5x16-82°	T20
						3.0-6.5		TMCN19...		
TMC-092Z10300455BT50P19	115	92.00	80.0	300	455	1.5-3.0	10	TMCN19...	M5x16-82°	T20
						3.0-6.5		TMCN19...		
TMC-092Z07300455BT50P28	115	92.00	76.0	300	455	1.5-6.0	7	TMCN28...	M5x19-82°	T20
						6.0-8.0		TMCN28...		

**ПЛАСТИНЫ. НЕПОЛНЫЙ ПРОФИЛЬ 60°.
МЕТРИЧЕСКАЯ РЕЗЬБА М, МF. DIN 13.
АМЕРИКАНСКАЯ УНИФИЦИРОВАННАЯ РЕЗЬБА UN. ANSI B1.1**



Рис. 1

Рис. 2

P	★	☆	☆
M	☆	★	
K	☆		★
N	☆		
S		☆	
H			

Сплавы

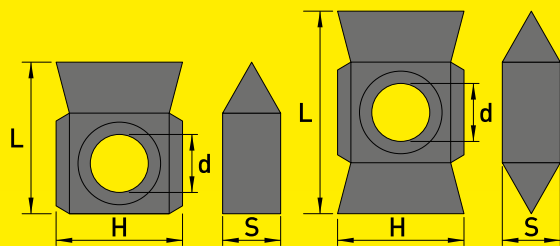
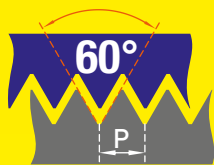
УРП	Артикул	P мм	L мм	TPI (G/1")	H мм	S мм	d мм	Рис.	MP17	MM27	MK37
7	TMCN070 1530	1.5-3.0	7.00	16-9.0	5.0	3.18	2.8	1	⊙	⊙	⊙
9	TMCN095 1525	1.5-2.5	9.52	16-10.0	6.4	3.18	2.8	2	⊙	⊙	⊙
9	TMCN095 2540	2.5-4.0	9.52	10-6.0	6.4	3.18	2.8	2	⊙	⊙	⊙
13	TMCN135 1525	1.5-2.5	13.50	16-10.0	8.5	4.80	3.4	2	⊙	⊙	⊙
13	TMCN135 2555	2.5-5.5	13.50	10-4.5	8.5	4.80	3.4	2	⊙	⊙	⊙
13	TMCN155 1530	1.5-3.0	15.50	16-9.0	9.5	5.00	4.3	2	⊙	⊙	⊙
15	TMCN155 3060	3.0-6.0	15.50	9-4.0	9.5	5.00	4.3	2	⊙	⊙	⊙
15	TMCN155 1530	1.5-3.0	15.50	16-9.0	9.5	5.00	4.4	2	⊙	⊙	⊙
15	TMCN155 3060	3.0-6.0	15.50	9-4.0	9.5	5.00	4.4	2	⊙	⊙	⊙
19	TMCN190 1530	1.5-3.0	19.00	16-9.0	12.5	6.00	5.4	2	⊙	⊙	⊙
19	TMCN190 3065	3.0-6.5	19.00	9-4.0	12.5	6.00	5.4	2	⊙	⊙	⊙
28	TMCN280 1560	1.5-6.0	28.58	16-4.0	14.3	9.52	5.4	2	⊙	⊙	⊙
28	TMCN280 6080	6.0-8.0	28.58	4.0	14.3	9.52	5.4	2	⊙	⊙	⊙



РАЗДЕЛ 8.

ФРЕЗЫ

УНИВЕРСАЛЬНЫЕ.

ОБЩАЯ ОБРАБОТКА МАТЕРИАЛОВ
ГРУПП Р, М, К

8.1. ФРЕЗЫ
С ПЛОСКИМ
ТОРЦОМ

СЕРИИ WM074/WM075 (плоский торец, обнижение рабочей части)

Фрезы твердосплавные концевые с обнижением рабочей части для общей универсальной обработки материалов 35–45 HRC: углеродистых, конструкционных, легированных и термоупрочненных сталей, нержавеющей сталей, чугунов, меди, FRP.

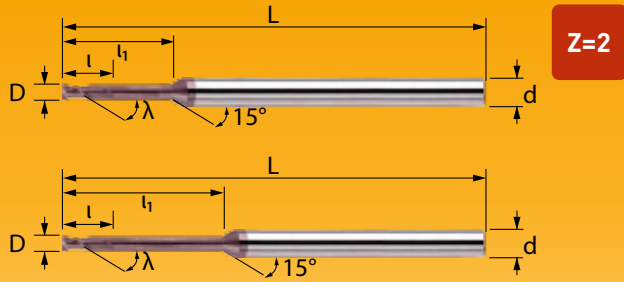

Z=2

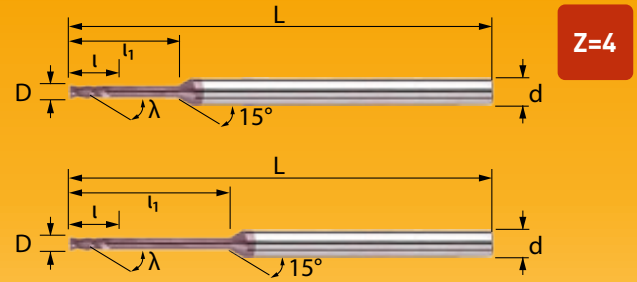

Z=4

рис.1 z=2 D=0,2—12,0 мм

рис.2 z=4 D=1,0—12,0 мм

- Высокопроизводительная геометрия и прочная конструкция спирали позволяют работать на повышенной скорости резания, с более высокой скоростью подачи, что увеличивает объем удаляемого материала и ведет к повышению производительности.
- Исполнение с высокотехнологичным покрытием AlTiCrN увеличивает износостойкость и снижает коэффициент трения.
- Широкий диапазон рабочей длины.
- Применяется для глубокой обработки.

Артикулы		D, мм	Точность исполнения рабочей части, мм	l, мм		l ₁ , мм	L, мм	d, мм
рис. 1, z=2 WM074~	рис. 2, z=4 WM075~			z=2	z=4			
~00204S0000.002.050	—	0,2	0,3	—	2	50	4	
~00304S0000.001.050	—	0,3	0,4	—	1	50	4	
~00304S0000.002.050	—	0,3	0,4	—	2	50	4	
~00304S0000.003.050	—	0,3	0,4	—	3	50	4	
~00304S0000.004.050	—	0,3	0,4	—	4	50	4	
~00304S0000.005.050	—	0,3	0,4	—	5	50	4	
~00404S0000.001.050	—	0,4	0,5	—	1	50	4	
~00404S0000.002.050	—	0,4	0,5	—	2	50	4	
~00404S0000.003.050	—	0,4	0,5	—	3	50	4	
~00404S0000.004.050	—	0,4	0,5	—	4	50	4	
~00404S0000.005.050	—	0,4	0,5	—	5	50	4	
~00404S0000.006.050	—	0,4	0,5	—	6	50	4	
~00404S0000.008.050	—	0,4	0,5	—	8	50	4	
~00404S0000.010.050	—	0,4	0,5	—	10	50	4	
~00504S0000.002.050	—	0,5	0,6	—	2	50	4	
~00504S0000.003.050	—	0,5	0,6	—	3	50	4	
~00504S0000.004.050	—	0,5	0,6	—	4	50	4	
~00504S0000.005.050	—	0,5	0,6	—	5	50	4	
~00504S0000.006.050	—	0,5	0,6	—	6	50	4	
~00504S0000.008.050	—	0,5	0,6	—	8	50	4	
~00504S0000.010.050	—	0,5	0,6	—	10	50	4	
~00504S0000.012.050	—	0,5	0,6	—	12	50	4	
~00504S0000.014.050	—	0,5	0,6	—	14	50	4	
~00604S0000.002.050	—	0,6	0,7	—	2	50	4	
~00604S0000.003.050	—	0,6	0,7	—	3	50	4	
~00604S0000.004.050	—	0,6	0,7	—	4	50	4	
~00604S0000.005.050	—	0,6	0,7	—	5	50	4	
~00604S0000.006.050	—	0,6	0,7	—	6	50	4	
~00604S0000.008.050	—	0,6	0,7	—	8	50	4	
~00604S0000.010.050	—	0,6	0,7	—	10	50	4	
~00604S0000.012.050	—	0,6	0,7	—	12	50	4	
~00604S0000.014.050	—	0,6	0,7	—	14	50	4	
~00604S0000.016.050	—	0,6	0,7	—	16	50	4	

0 ~ -0,02

Z=2 **Z=4**

AlTiCrN **MG**

λ=30° **HRC 55**

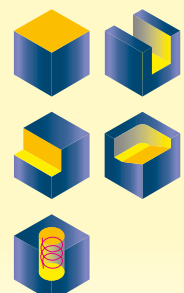

Продолжение таблицы см. на следующей странице



СЕРИИ WM074/WM075 (плоский торец, обнижение рабочей части, продолжение размерного ряда)



Артикулы		D, мм	Точность исполнения рабочей части, мм	l, мм		l ₁ , мм	L, мм	d, мм
рис. 1, z=2 WM074~	рис. 2, z=4 WM075~			z=2	z=4			
~00704S0000.002.050	—	0,7	0 ~ -0,02	0,8	—	2	50	4
~00704S0000.004.050	—	0,7		0,8	—	4	50	4
~00704S0000.006.050	—	0,7		0,8	—	6	50	4
~00704S0000.008.050	—	0,7		0,8	—	8	50	4
~00704S0000.010.050	—	0,7		0,8	—	10	50	4
~00704S0000.012.050	—	0,7		0,8	—	12	50	4
~00804S0000.002.050	—	0,8		1,0	—	2	50	4
~00804S0000.004.050	—	0,8		1,0	—	4	50	4
~00804S0000.006.050	—	0,8		1,0	—	6	50	4
~00804S0000.008.050	—	0,8		1,0	—	8	50	4
~00804S0000.010.050	—	0,8		1,0	—	10	50	4
~00804S0000.012.050	—	0,8		1,0	—	12	50	4
~00804S0000.014.050	—	0,8		1,0	—	14	50	4
~00904S0000.006.050	—	0,9		1,1	—	6	50	4
~00904S0000.008.050	—	0,9		1,1	—	8	50	4
~00904S0000.010.050	—	0,9		1,1	—	10	50	4
~01004S0000.002.050	—	1,0		1,2	—	2	50	4
~01004S0000.003.050	~01004S0000.003.050	1,0		1,2	1,0	3	50	4
~01004S0000.004.050	~01004S0000.004.050	1,0		1,2	1,0	4	50	4
—	~01006S0000.004.050	1,0		—	1,0	4	50	6
~01004S0000.005.050	—	1,0		1,2	—	5	50	4
~01004S0000.006.050	~01004S0000.006.050	1,0		1,2	1,0	6	50	4
—	~01006S0000.006.050	1,0		—	1,0	6	50	6
~01004S0000.008.050	~01004S0000.008.050	1,0		1,2	1,0	8	50	4
—	~01006S0000.008.050	1,0		—	1,0	8	50	6
~01004S0000.010.050	~01004S0000.010.050	1,0		1,2	1,0	10	50	4
—	~01006S0000.010.050	1,0		—	1,0	10	50	6
~01004S0000.012.050	~01004S0000.012.050	1,0		1,2	1,0	12	50	4
—	~01006S0000.012.050	1,0		—	1,0	12	50	6
~01004S0000.014.050	—	1,0		1,2	—	14	50	4
~01004S0000.016.050	~01004S0000.016.050	1,0		1,2	1,0	16	50	4
~01004S0000.018.050	—	1,0		1,2	—	18	50	4
~01004S0000.020.050	~01004S0000.020.050	1,0		1,2	1,0	20	50	4
—	~01004S0000.025.060	1,0		—	1,0	25	60	4
~01204S0000.004.050	—	1,2		1,5	—	4	50	4
~01204S0000.006.050	—	1,2		1,5	—	6	50	4
~01204S0000.008.050	—	1,2		1,5	—	8	50	4
~01204S0000.010.050	—	1,2		1,5	—	10	50	4
~01204S0000.012.050	—	1,2		1,5	—	12	50	4
~01204S0000.016.050	—	1,2		1,5	—	16	50	4
~01204S0000.020.050	—	1,2	1,5	—	20	50	4	
~01404S0000.006.050	—	1,4	1,8	—	6	50	4	
~01404S0000.008.050	—	1,4	1,8	—	8	50	4	
~01404S0000.010.050	—	1,4	1,8	—	10	50	4	
~01404S0000.014.050	—	1,4	1,8	—	14	50	4	
~01404S0000.016.050	—	1,4	1,8	—	16	50	4	
~01404S0000.020.050	—	1,4	1,8	—	20	50	4	
~01504S0000.004.050	—	1,5	1,8	—	4	50	4	
~01504S0000.006.050	~01504S0000.006.050	1,5	1,8	1,5	6	50	4	
—	~01506S0000.006.050	1,5	—	1,5	6	50	6	
~01504S0000.008.050	~01504S0000.008.050	1,5	1,8	1,5	8	50	4	
—	~01506S0000.008.050	1,5	—	1,5	8	50	6	
~01504S0000.010.050	~01504S0000.010.050	1,5	1,8	1,5	10	50	4	

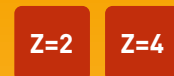

Продолжение таблицы см. на следующей странице

Пример заказа фрез: код инструмента WM075 + код размера 01004S0000.003.050 = WM07501004S0000.003.050



ФРЕЗЫ УНИВЕРСАЛЬНЫЕ. ОБЩАЯ ОБРАБОТКА МАТЕРИАЛОВ ГРУПП Р, М, К

СЕРИИ WM074/WM075 (плоский торец, обнижение рабочей части, продолжение размерного ряда)



Артикулы		D, мм	Точность исполнения рабочей части, мм	l, мм		l ₁ , мм	L, мм	d, мм
рис. 1, z=2 WM074~	рис. 2, z=4 WM075~			z=2	z=4			
—	~01506S0000.010.050	1,5	0 ~ -0,02	—	1,5	10	50	6
~01504S0000.012.050	~01504S0000.012.050	1,5		1,8	1,5	12	50	4
—	~01506S0000.012.050	1,5		—	1,5	12	50	6
~01504S0000.014.050	—	1,5		1,8	—	14	50	4
~01504S0000.016.050	~01504S0000.016.050	1,5		1,8	1,5	16	50	4
~01504S0000.018.050	—	1,5		1,8	—	18	50	4
~01504S0000.020.050	~01504S0000.020.050	1,5		1,8	1,5	20	50	4
—	~01504S0000.025.060	1,5		—	1,5	25	60	4
~01604S0000.010.050	—	1,6		1,9	—	10	50	4
~01604S0000.014.050	—	1,6		1,9	—	14	50	4
~01604S0000.018.050	—	1,6		1,9	—	18	50	4
~01804S0000.010.050	—	1,8		2,0	—	10	50	4
~01804S0000.014.050	—	1,8		2,0	—	14	50	4
~01804S0000.018.050	—	1,8		2,0	—	18	50	4
~02004S0000.004.050	—	2,0		2,5	—	4	50	4
~02004S0000.006.050	~02004S0000.006.050	2,0		2,5	2,0	6	50	4
—	~02006S0000.006.050	2,0		—	2,0	6	50	6
~02004S0000.008.050	~02004S0000.008.050	2,0		2,5	2,0	8	50	4
—	~02006S0000.008.050	2,0		—	2,0	8	50	6
~02004S0000.010.050	~02004S0000.010.050	2,0		2,5	2,0	10	50	4
—	~02006S0000.010.050	2,0		—	2,0	10	50	6
~02004S0000.012.050	~02004S0000.012.050	2,0		2,5	2,0	12	50	4
~02004S0000.014.050	—	2,0		2,5	—	14	50	4
~02004S0000.016.050	~02004S0000.016.050	2,0		2,5	2,0	16	50	4
—	~02006S0000.016.050	2,0		—	2,0	16	50	6
~02004S0000.018.050	—	2,0		2,5	—	18	50	4
~02004S0000.020.050	~02004S0000.020.050	2,0		2,5	2,0	20	50	4
~02004S0000.022.060	—	2,0		2,5	—	22	60	4
~02004S0000.025.060	~02004S0000.025.060	2,0		2,5	2,0	25	60	4
~02004S0000.030.075	~02004S0000.030.075	2,0		2,5	2,0	30	75	4
~02004S0000.035.075	—	2,0		2,5	—	35	75	4
—	~02506S0000.006.050	2,5		—	2,5	6	50	6
~02504S0000.008.050	—	2,5		3,0	—	8	50	4
~02504S0000.010.050	~02504S0000.010.050	2,5		3,0	2,5	10	50	4
—	~02506S0000.010.050	2,5		—	2,5	10	50	6
~02504S0000.012.050	~02504S0000.012.050	2,5		3,0	2,5	12	50	4
~02504S0000.016.050	~02504S0000.016.050	2,5		3,0	2,5	16	50	4
~02504S0000.020.050	~02504S0000.020.050	2,5		3,0	2,5	20	50	4
~02504S0000.025.060	~02504S0000.025.060	2,5		3,0	2,5	25	60	4
~02504S0000.030.075	~02504S0000.030.075	2,5		3,0	2,5	30	75	4
~02504S0000.035.075	—	2,5		3,0	—	35	75	4
~03006S0000.006.050	—	3,0		3,5	—	6	50	6
~03006S0000.010.050	~03006S0000.010.050	3,0	3,5	3,0	10	50	6	
~03006S0000.012.050	~03006S0000.012.050	3,0	3,5	3,0	12	50	6	
~03006S0000.016.050	~03006S0000.016.050	3,0	3,5	3,0	16	50	6	
~03006S0000.020.060	~03006S0000.020.060	3,0	3,5	3,0	20	60	6	
~03006S0000.025.060	~03006S0000.025.060	3,0	3,5	3,0	25	60	6	
~03006S0000.030.075	~03006S0000.030.075	3,0	3,5	3,0	30	75	6	
~03006S0000.035.075	~03006S0000.035.075	3,0	3,5	3,0	35	75	6	
~04006S0000.008.050	—	4,0	4,5	—	8	50	6	
~04006S0000.010.050	~04006S0000.010.050	4,0	4,5	4,0	10	50	6	
~04006S0000.012.050	~04006S0000.012.050	4,0	4,5	4,0	12	50	6	
~04006S0000.016.050	~04006S0000.016.050	4,0	4,5	4,0	16	50	6	

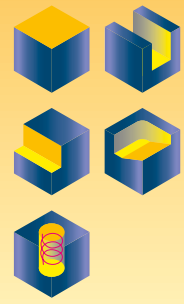

Продолжение таблицы см. на следующей странице

Пример заказа фрез: код инструмента WM075 + код размера 01004S0000.003.050 = WM07501004S0000.003.050

СЕРИИ WM074/WM075 (плоский торец, обнижение рабочей части, продолжение размерного ряда)



Артикулы		D, мм	Точность исполнения рабочей части, мм	l, мм		l ₁ , мм	L, мм	d, мм
рис. 1, z=2 WM074~	рис. 2, z=4 WM075~			z=2	z=4			
~04006S0000.020.060	~04006S0000.020.060	4,0	0 ~ -0,02	4,5	4,0	20	60	6
~04006S0000.025.060	~04006S0000.025.060	4,0		4,5	4,0	25	60	6
~04006S0000.030.075	~04006S0000.030.075	4,0		4,5	4,0	30	75	6
~04006S0000.035.075	—	4,0		4,5	—	35	75	6
~05006S0000.016.050	~05006S0000.016.050	5,0		7,0	5,0	16	50	6
~05006S0000.020.060	~05006S0000.020.060	5,0		7,0	5,0	20	60	6
~05006S0000.025.060	~05006S0000.025.060	5,0		7,0	5,0	25	60	6
~05006S0000.030.075	~05006S0000.030.075	5,0		7,0	5,0	30	75	6
~05006S0000.035.075	—	5,0		7,0	—	35	75	6
~06006S0000.020.060	~06006S0000.020.060	6,0		10,0	6,0	20	60	6
~06006S0000.030.075	~06006S0000.030.075	6,0	10,0	6,0	30	75	6	
~08008S0000.020.060	~08008S0000.020.060	8,0	0 ~ -0,03	15,0	15,0	20	60	8
~08008S0000.030.075	~08008S0000.030.075	8,0		15,0	15,0	30	75	8
~08008S0000.040.100	~08008S0000.040.100	8,0		15,0	15,0	40	100	8
~10010S0000.025.075	~10010S0000.025.075	10,0		20,0	20,0	25	75	10
~10010S0000.035.075	—	10,0		20,0	—	35	75	10
—	~10010S0000.035.100	10,0		—	20,0	35	100	10
~10010S0000.045.100	~10010S0000.045.100	10,0		20,0	20,0	45	100	10
~12012S0000.030.075	~12012S0000.030.075	12,0		25,0	25,0	30	75	12
~12012S0000.040.100	~12012S0000.040.100	12,0		25,0	25,0	40	100	12
~12012S0000.050.100	~12012S0000.050.100	12,0		25,0	25,0	50	100	12

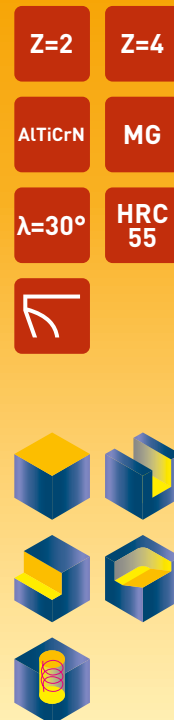

РЕЖИМЫ РЕЗАНИЯ ДЛЯ ФРЕЗ СЕРИЙ WM074/WM075

Материалы		Углеродистые стали/Чугуны/Легированные стали					
Твердость		35–45 HRC					
D, мм	l	N, об./мин		V _f , мм/мин		a _p , мм	
		z=2	z=4	z=2	z=4	z=2	z=4
0,2	1	40000	—	400	—	0,001	—
	2	40000	—	200	—	0,005	—
0,3	1	40000	—	650	—	0,007	—
	2	40000	—	550	—	0,004	—
	3	40000	—	500	—	0,002	—
	4	30000	—	200	—	0,001	—
0,4	2	40000	—	800	—	0,007	—
	4	40000	—	800	—	0,003	—
	6	28000	—	350	—	0,001	—
	8	20000	—	200	—	0,001	—
0,5	10	17000	—	150	—	0,001	—
	4	40000	—	850	—	0,003	—
	6	40000	—	700	—	0,003	—
	8	30000	—	500	—	0,002	—
0,6	12	20000	—	300	—	0,001	—
	14	14000	—	150	—	0,001	—
	4	40000	—	950	—	0,010	—
	8	35000	—	500	—	0,004	—
0,7	10	25000	—	450	—	0,003	—
	12	20000	—	300	—	0,002	—
	16	12000	—	150	—	0,001	—
	4	40000	—	950	—	0,015	—
0,8	8	30000	—	700	—	0,005	—
	12	9000	—	200	—	0,002	—
	4	40000	—	1100	—	0,015	—
	8	40000	—	1000	—	0,010	—
0,9	12	25000	—	400	—	0,030	—
	14	20000	—	300	—	0,020	—
	6	40000	—	1300	—	0,020	—
	8	38000	—	1200	—	0,010	—
0,9	10	35000	—	1000	—	0,010	—

Материалы		Углеродистые стали/Чугуны/Легированные стали					
Твердость		35–45 HRC					
D, мм	l	N, об./мин		V _f , мм/мин		a _p , мм	
		z=2	z=4	z=2	z=4	z=2	z=4
0,6	4	40000	—	950	—	0,010	—
	8	35000	—	500	—	0,004	—
	10	25000	—	450	—	0,003	—
	12	20000	—	300	—	0,002	—
0,7	16	12000	—	150	—	0,001	—
	4	40000	—	950	—	0,015	—
	8	30000	—	700	—	0,005	—
	12	9000	—	200	—	0,002	—
0,8	4	40000	—	1100	—	0,015	—
	8	40000	—	1000	—	0,010	—
	12	25000	—	400	—	0,030	—
	14	20000	—	300	—	0,020	—
0,9	6	40000	—	1300	—	0,020	—
	8	38000	—	1200	—	0,010	—
	10	35000	—	1000	—	0,010	—

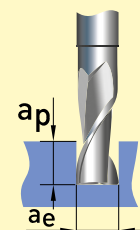

1. Необходимо стремиться к наибольшей жесткости системы СПИД.
2. В случае изменения скорости резания V_c (количества оборотов/мин, N), скорость подачи (V_f) необходимо пропорционально изменить.
3. При увеличении вылета инструмента требуется уменьшить обороты и скорость подачи.
4. Режимы резания носят исключительно рекомендательный характер. Окончательные значения режимов резания уточняются на стадии отработки конкретной технологической операции в производственных условиях.

РЕЖИМЫ РЕЗАНИЯ ДЛЯ ФРЕЗ СЕРИЙ WM074/WM075

Материалы		Углеродистые стали/Чугуны/Легированные стали						
Твердость		35–45 HRC						
D, мм	l	N, об./мин		V _f , мм/мин		a _p , мм		
		z=2	z=4	z=2	z=4	z=2	z=4	
1,0	4	—	40000	—	3000	—	0,040	
	6	40000	—	1600	—	0,040	—	
	8	40000	36000	1600	2400	0,030	0,030	
	10	38000	30000	1300	1500	0,025	0,025	
	12	30000	20000	1000	1000	0,020	0,020	
	16	23000	10000	600	500	0,010	0,005	
	20	15000	—	400	—	0,005	—	
1,2	6	40000	—	1900	—	0,060	—	
	10	35000	—	1500	—	0,040	—	
	16	15000	—	500	—	0,020	—	
1,4	6	40000	—	1900	—	0,060	—	
	10	35000	—	1500	—	0,040	—	
	16	15000	—	500	—	0,020	—	
1,4	20	6500	—	150	—	0,010	—	
	1,5	6	40000	40000	2400	3200	0,100	0,060
		10	30000	35000	1800	2500	0,050	0,050
12		28000	32000	1300	2400	0,040	0,050	
16		20000	16000	800	1100	0,020	0,030	
20		15000	10000	600	600	0,020	0,010	
25	—	9000	—	500	—	0,009		
1,6	10	30000	—	1800	—	0,070	—	
	14	25000	—	1500	—	0,050	—	
	18	20000	—	1000	—	0,040	—	
1,8	10	30000	—	1800	—	0,070	—	
	14	25000	—	1500	—	0,050	—	
	18	20000	—	1000	—	0,040	—	
2,0	6	40000	40000	2400	4000	0,180	0,100	
	10	30000	35000	1800	3500	0,100	0,080	
	12	25000	32000	1500	3200	0,080	0,070	
	16	20000	24000	1000	2400	0,060	0,050	
	20	12000	12000	800	1200	0,050	0,030	
	25	9000	10000	600	800	0,040	0,020	
	30	8000	5000	500	500	0,040	0,010	
35	6500	—	300	—	0,020	—		

Материалы		Углеродистые стали/Чугуны/Легированные стали					
Твердость		35–45 HRC					
D, мм	l	N, об./мин		V _f , мм/мин		a _p , мм	
		z=2	z=4	z=2	z=4	z=2	z=4
2,5	8	25000	—	2500	—	0,200	—
	10	—	32000	—	4000	—	0,200
	12	20000	28000	2000	2500	0,150	0,120
	16	18000	23000	1700	1800	0,100	0,100
	20	12000	20000	1000	1500	0,080	0,060
	25	10000	9000	700	1100	0,070	0,040
	30	9000	2500	600	300	0,060	0,005
	35	8500	—	500	—	0,050	—
3,0	8	20000	—	2000	—	0,300	—
	10	—	25000	—	3600	—	0,400
	12	20000	23000	1500	3000	0,180	0,300
	16	15000	18000	1400	2500	0,150	0,200
	20	10000	15000	800	2000	0,100	0,150
	25	8000	12000	600	1700	0,080	0,100
	30	7000	7000	450	800	0,060	0,050
35	6000	5000	300	300	0,050	0,030	
4,0	10	20000	20000	3200	3200	0,300	1,200
	12	—	18000	—	3000	—	1,000
	16	13000	15000	2500	2500	0,250	1,000
	20	11000	12000	2200	2000	0,220	0,500
	25	8000	10000	1500	1800	0,150	0,400
	30	6400	8000	1200	1300	0,120	0,200
5,0	35	5000	—	700	—	0,080	—
	16	12000	—	2500	—	0,350	—
	20	10000	12000	1200	2300	0,300	1,000
	25	8000	9500	1000	1800	0,250	0,500
	30	6000	6400	900	1200	0,200	0,200
6,0	35	5100	—	750	—	0,150	—
	20	10000	11000	2000	2200	0,400	1,200
	30	6000	8000	1200	1600	0,300	0,600
8,0	20	3200	8000	910	1600	0,180	1,000
	30	3000	4000	800	800	0,150	0,500
	40	2600	4000	600	800	0,120	0,500
10,0	25	2900	6400	890	1300	0,200	1,000
	35	2500	3200	700	640	0,160	0,600
	45	2200	3200	580	640	0,140	0,600
12,0	30	2500	6000	710	1200	0,220	2,000
	40	2300	3200	500	640	0,180	0,600
	50	1900	3200	420	640	0,160	0,600

1. Необходимо стремиться к наибольшей жесткости системы СПИД.
2. В случае изменения скорости резания V_c (количества оборотов/мин, N), скорость подачи (V_f) необходимо пропорционально изменить.
3. При увеличении вылета инструмента требуется уменьшить обороты и скорость подачи.
4. Режимы резания носят исключительно рекомендательный характер. Окончательные значения режимов резания уточняются на стадии отработки конкретной технологической операции в производственных условиях.

СЕРИИ WM077/WM078

(плоский торец с угловым радиусом, обнижение рабочей части)

Фрезы твердосплавные концевые с обнижением рабочей части для общей универсальной обработки материалов 25–55 HRC: углеродистых, конструкционных, легированных и термоупрочненных сталей, нержавеющей сталей, чугунов.



рис.1 z=2 d=1,0—12,0 мм



рис.2 z=4 d=2,0—12,0 мм

- Высокопроизводительная геометрия и прочная конструкция спирали позволяют работать на повышенной скорости резания, с более высокой скоростью подачи, что увеличивает объем удаляемого материала и ведет к повышению производительности.
- Исполнение с высокотехнологичным покрытием AlTiCrN увеличивает износостойкость и снижает коэффициент трения.
- Широкий диапазон рабочей длины.
- Угловой радиус позволяет осуществлять 3D-фрезерование.
- Длинная шейка предназначена для большой глубины фрезерования.

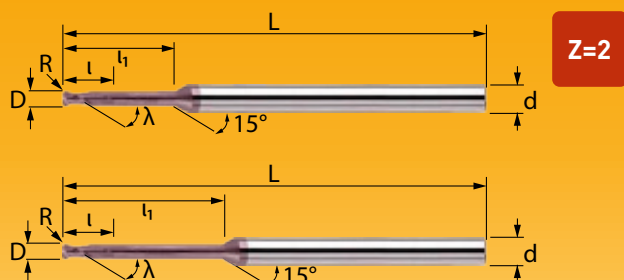
Артикулы		D, мм	R, мм	Допуск D, мм	Допуск R, мм	l, мм		l ₁ , мм	L, мм	d, мм
рис. 1, z=2 WM077~	рис. 2, z=4 WM078~					z=2	z=4			
~01004R0010.004.050	—	1,0	0,1	0 ~ -0,02	±0,015	1,0	—	4	50	4
~01004R0020.004.050	—	1,0	0,2			1,0	—	4	50	4
~01004R0030.004.050	—	1,0	0,3			1,0	—	4	50	4
~01004R0010.006.050	—	1,0	0,1			1,0	—	6	50	4
~01004R0020.006.050	—	1,0	0,2			1,0	—	6	50	4
~01004R0030.006.050	—	1,0	0,3			1,0	—	6	50	4
~01004R0010.008.050	—	1,0	0,1			1,0	—	8	50	4
~01004R0020.008.050	—	1,0	0,2			1,0	—	8	50	4
~01004R0030.008.050	—	1,0	0,3			1,0	—	8	50	4
~01004R0010.010.050	—	1,0	0,1			1,0	—	10	50	4
~01004R0020.010.050	—	1,0	0,2			1,0	—	10	50	4
~01004R0030.010.050	—	1,0	0,3			1,0	—	10	50	4
~01004R0010.012.050	—	1,0	0,1			1,0	—	12	50	4
~01004R0020.012.050	—	1,0	0,2			1,0	—	12	50	4
~01004R0030.012.050	—	1,0	0,3			1,0	—	12	50	4
~01204R0010.004.050	—	1,2	0,1			1,2	—	4	50	4
~01204R0020.004.050	—	1,2	0,2			1,2	—	4	50	4
~01204R0030.004.050	—	1,2	0,3			1,2	—	4	50	4
~01204R0010.006.050	—	1,2	0,1			1,2	—	6	50	4
~01204R0020.006.050	—	1,2	0,2			1,2	—	6	50	4
~01204R0030.006.050	—	1,2	0,3			1,2	—	6	50	4
~01204R0010.008.050	—	1,2	0,1			1,2	—	8	50	4
~01204R0020.008.050	—	1,2	0,2			1,2	—	8	50	4
~01204R0030.008.050	—	1,2	0,3			1,2	—	8	50	4
~01204R0010.010.050	—	1,2	0,1			1,2	—	10	50	4
~01204R0020.010.050	—	1,2	0,2			1,2	—	10	50	4
~01204R0030.010.050	—	1,2	0,3			1,2	—	10	50	4
~01204R0010.012.050	—	1,2	0,1			1,2	—	12	50	4
~01204R0020.012.050	—	1,2	0,2			1,2	—	12	50	4
~01204R0030.012.050	—	1,2	0,3			1,2	—	12	50	4
~01504R0010.006.050	—	1,5	0,1	1,5	—	6	50	4		
~01504R0020.006.050	—	1,5	0,2	1,5	—	6	50	4		
~01504R0030.006.050	—	1,5	0,3	1,5	—	6	50	4		
~01504R0050.006.050	—	1,5	0,5	1,5	—	6	50	4		

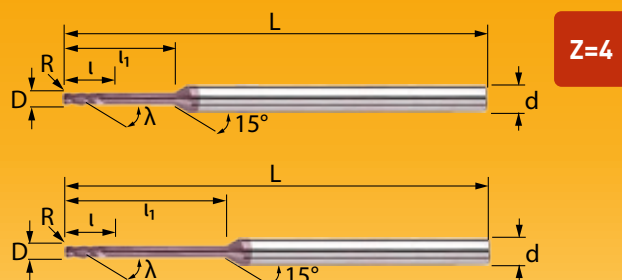

Продолжение таблицы см. на следующей странице

Пример заказа фрез: код инструмента WM077 + код размера 01004R0010.004.050 = WM07701004R0010.004.050



СЕРИИ WM077/WM078

**(плоский торец с угловым радиусом, обнижение рабочей части,
продолжение размерного ряда)**



Артикулы		D, мм	R, мм	Допуск D, мм	Допуск R, мм	l, мм		l ₁ , мм	L, мм	d, мм
рис. 1, z=2 WM077~	рис. 2, z=4 WM078~					z=2	z=4			
~01504R0010.008.050	—	1,5	0,1	0 ~ -0,02	±0,015	1,5	—	8	50	4
~01504R0020.008.050	—	1,5	0,2			1,5	—	8	50	4
~01504R0030.008.050	—	1,5	0,3			1,5	—	8	50	4
~01504R0050.008.050	—	1,5	0,5			1,5	—	8	50	4
~01504R0010.010.050	—	1,5	0,1			1,5	—	10	50	4
~01504R0020.010.050	—	1,5	0,2			1,5	—	10	50	4
~01504R0030.010.050	—	1,5	0,3			1,5	—	10	50	4
~01504R0050.010.050	—	1,5	0,5			1,5	—	10	50	4
~01504R0010.012.050	—	1,5	0,1			1,5	—	12	50	4
~01504R0020.012.050	—	1,5	0,2			1,5	—	12	50	4
~01504R0030.012.050	—	1,5	0,3			1,5	—	12	50	4
~01504R0050.012.050	—	1,5	0,5			1,5	—	12	50	4
~01504R0010.016.050	—	1,5	0,1			1,5	—	16	50	4
~01504R0020.016.050	—	1,5	0,2			1,5	—	16	50	4
~01504R0030.016.050	—	1,5	0,3			1,5	—	16	50	4
~01504R0050.016.050	—	1,5	0,5			1,5	—	16	50	4
~02004R0010.006.050	~02004R0010.006.050	2,0	0,1			2,0	2,0	6	50	4
~02004R0020.006.050	~02004R0020.006.050	2,0	0,2			2,0	2,0	6	50	4
~02004R0030.006.050	~02004R0030.006.050	2,0	0,3			2,0	2,0	6	50	4
~02004R0050.006.050	~02004R0050.006.050	2,0	0,5			2,0	2,0	6	50	4
~02004R0010.008.050	~02004R0010.008.050	2,0	0,1			2,0	2,0	8	50	4
~02004R0020.008.050	~02004R0020.008.050	2,0	0,2			2,0	2,0	8	50	4
~02004R0030.008.050	~02004R0030.008.050	2,0	0,3			2,0	2,0	8	50	4
~02004R0050.008.050	~02004R0050.008.050	2,0	0,5			2,0	2,0	8	50	4
~02004R0010.010.050	~02004R0010.010.050	2,0	0,1			2,0	2,0	10	50	4
~02004R0020.010.050	~02004R0020.010.050	2,0	0,2			2,0	2,0	10	50	4
~02004R0030.010.050	~02004R0030.010.050	2,0	0,3			2,0	2,0	10	50	4
~02004R0050.010.050	~02004R0050.010.050	2,0	0,5			2,0	2,0	10	50	4
~02006R0050.010.050	~02006R0050.010.050	2,0	0,5			2,0	2,0	10	50	6
~02004R0010.012.050	~02004R0010.012.050	2,0	0,1			2,0	2,0	12	50	4
~02004R0020.012.050	~02004R0020.012.050	2,0	0,2			2,0	2,0	12	50	4
~02004R0030.012.050	~02004R0030.012.050	2,0	0,3			2,0	2,0	12	50	4
~02004R0050.012.050	~02004R0050.012.050	2,0	0,5			2,0	2,0	12	50	4
~02006R0050.015.050	~02006R0050.015.050	2,0	0,5			2,0	2,0	15	50	6
~02004R0010.016.050	~02004R0010.016.050	2,0	0,1			2,0	2,0	16	50	4
~02004R0020.016.050	~02004R0020.016.050	2,0	0,2			2,0	2,0	16	50	4
~02004R0030.016.050	~02004R0030.016.050	2,0	0,3			2,0	2,0	16	50	4
~02004R0050.016.050	~02004R0050.016.050	2,0	0,5			2,0	2,0	16	50	4
~02004R0010.020.050	~02004R0010.020.050	2,0	0,1			2,0	2,0	20	50	4
~02004R0020.020.050	~02004R0020.020.050	2,0	0,2			2,0	2,0	20	50	4
~02004R0030.020.050	~02004R0030.020.050	2,0	0,3	2,0	2,0	20	50	4		
~02004R0050.020.050	~02004R0050.020.050	2,0	0,5	2,0	2,0	20	50	4		
~02004R0010.025.060	~02004R0010.025.060	2,0	0,1	2,0	2,0	25	60	4		
~02004R0020.025.060	~02004R0020.025.060	2,0	0,2	2,0	2,0	25	60	4		
~02004R0030.025.060	~02004R0030.025.060	2,0	0,3	2,0	2,0	25	60	4		
~02004R0050.025.060	~02004R0050.025.060	2,0	0,5	2,0	2,0	25	60	4		
~02504R0010.010.050	~02504R0010.010.050	2,5	0,1	2,5	2,5	10	50	4		
~02504R0020.010.050	~02504R0020.010.050	2,5	0,2	2,5	2,5	10	50	4		
~02504R0030.010.050	~02504R0030.010.050	2,5	0,3	2,5	2,5	10	50	4		
~02504R0050.010.050	~02504R0050.010.050	2,5	0,5	2,5	2,5	10	50	4		
~02504R0010.016.050	~02504R0010.016.050	2,5	0,1	2,5	2,5	16	50	4		
~02504R0020.016.050	~02504R0020.016.050	2,5	0,2	2,5	2,5	16	50	4		
~02504R0030.016.050	~02504R0030.016.050	2,5	0,3	2,5	2,5	16	50	4		
~02504R0050.016.050	~02504R0050.016.050	2,5	0,5	2,5	2,5	16	50	4		

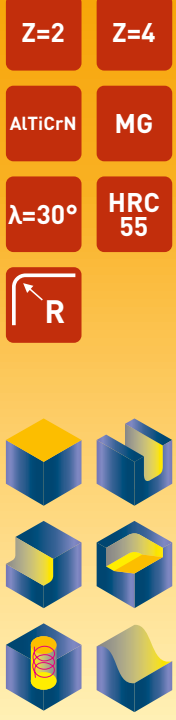

Продолжение таблицы см. на следующей странице



Пример заказа фрез: код инструмента WM077 + код размера 01004R0010.004.050 = WM07701004R0010.004.050

СЕРИИ WM077/WM078

(плоский торец с угловым радиусом, обнижение рабочей части, продолжение размерного ряда)



Артикулы		D, мм	R, мм	Допуск D, мм	Допуск R, мм	l, мм		l ₁ , мм	L, мм	d, мм
рис. 1, z=2 WM077~	рис. 2, z=4 WM078~					z=2	z=4			
~02504R0010.020.050	~02504R0010.020.050	2,5	0,1	0 ~ -0,02	±0,015	2,5	2,5	20	50	4
~02504R0020.020.050	~02504R0020.020.050	2,5	0,2			2,5	2,5	20	50	4
~02504R0030.020.050	~02504R0030.020.050	2,5	0,3			2,5	2,5	20	50	4
~02504R0050.020.050	~02504R0050.020.050	2,5	0,5			2,5	2,5	20	50	4
~02504R0010.025.060	~02504R0010.025.060	2,5	0,1			2,5	2,5	25	60	4
~02504R0020.025.060	~02504R0020.025.060	2,5	0,2			2,5	2,5	25	60	4
~02504R0030.025.060	~02504R0030.025.060	2,5	0,3			2,5	2,5	25	60	4
~02504R0050.025.060	~02504R0050.025.060	2,5	0,5			2,5	2,5	25	60	4
~03006R0010.010.050	~03006R0010.010.050	3,0	0,1			3,0	3,0	10	50	6
~03006R0020.010.050	~03006R0020.010.050	3,0	0,2			3,0	3,0	10	50	6
~03006R0030.010.050	~03006R0030.010.050	3,0	0,3			3,0	3,0	10	50	6
~03006R0050.010.050	~03006R0050.010.050	3,0	0,5			3,0	3,0	10	50	6
~03006R0100.010.050	~03006R0100.010.050	3,0	1,0			3,0	3,0	10	50	6
~03006R0010.016.060	~03006R0010.016.060	3,0	0,1			3,0	3,0	16	60	6
~03006R0020.016.060	~03006R0020.016.060	3,0	0,2			3,0	3,0	16	60	6
~03006R0030.016.060	~03006R0030.016.060	3,0	0,3			3,0	3,0	16	60	6
~03006R0050.016.060	~03006R0050.016.060	3,0	0,5			3,0	3,0	16	60	6
~03006R0100.016.060	~03006R0100.016.060	3,0	1,0			3,0	3,0	16	60	6
~03006R0010.020.060	~03006R0010.020.060	3,0	0,1			3,0	3,0	20	60	6
~03006R0020.020.060	~03006R0020.020.060	3,0	0,2			3,0	3,0	20	60	6
~03006R0030.020.060	~03006R0030.020.060	3,0	0,3			3,0	3,0	20	60	6
~03006R0050.020.060	~03006R0050.020.060	3,0	0,5			3,0	3,0	20	60	6
~03006R0100.020.060	~03006R0100.020.060	3,0	1,0			3,0	3,0	20	60	6
~03006R0010.025.060	~03006R0010.025.060	3,0	0,1			3,0	3,0	25	60	6
~03006R0020.025.060	~03006R0020.025.060	3,0	0,2			3,0	3,0	25	60	6
~03006R0030.025.060	~03006R0030.025.060	3,0	0,3			3,0	3,0	25	60	6
~03006R0050.025.060	~03006R0050.025.060	3,0	0,5			3,0	3,0	25	60	6
~03006R0100.025.060	~03006R0100.025.060	3,0	1,0			3,0	3,0	25	60	6
~03006R0010.030.075	~03006R0010.030.075	3,0	0,1			3,0	3,0	30	75	6
~03006R0020.030.075	~03006R0020.030.075	3,0	0,2			3,0	3,0	30	75	6
~03006R0030.030.075	~03006R0030.030.075	3,0	0,3			3,0	3,0	30	75	6
~03006R0050.030.075	~03006R0050.030.075	3,0	0,5			3,0	3,0	30	75	6
~03006R0100.030.075	~03006R0100.030.075	3,0	1,0			3,0	3,0	30	75	6
~03006R0010.035.075	~03006R0010.035.075	3,0	0,1			3,0	3,0	35	75	6
~03006R0020.035.075	~03006R0020.035.075	3,0	0,2			3,0	3,0	35	75	6
~03006R0030.035.075	~03006R0030.035.075	3,0	0,3			3,0	3,0	35	75	6
~03006R0050.035.075	~03006R0050.035.075	3,0	0,5			3,0	3,0	35	75	6
~03006R0100.035.075	~03006R0100.035.075	3,0	1,0			3,0	3,0	35	75	6
~04006R0010.013.050	~04006R0010.013.050	4,0	0,1			4,0	4,0	13	50	6
~04006R0020.013.050	~04006R0020.013.050	4,0	0,2			4,0	4,0	13	50	6
~04006R0030.013.050	~04006R0030.013.050	4,0	0,3	4,0	4,0	13	50	6		
~04006R0050.013.050	~04006R0050.013.050	4,0	0,5	4,0	4,0	13	50	6		
~04006R0100.013.050	~04006R0100.013.050	4,0	1,0	4,0	4,0	13	50	6		
~04006R0010.016.060	~04006R0010.016.060	4,0	0,1	4,0	4,0	16	60	6		
~04006R0020.016.060	~04006R0020.016.060	4,0	0,2	4,0	4,0	16	60	6		
~04006R0030.016.060	~04006R0030.016.060	4,0	0,3	4,0	4,0	16	60	6		
~04006R0050.016.060	~04006R0050.016.060	4,0	0,5	4,0	4,0	16	60	6		
~04006R0100.016.060	~04006R0100.016.060	4,0	1,0	4,0	4,0	16	60	6		
~04006R0010.020.060	~04006R0010.020.060	4,0	0,1	4,0	4,0	20	60	6		
~04006R0020.020.060	~04006R0020.020.060	4,0	0,2	4,0	4,0	20	60	6		
~04006R0030.020.060	~04006R0030.020.060	4,0	0,3	4,0	4,0	20	60	6		
~04006R0050.020.060	~04006R0050.020.060	4,0	0,5	4,0	4,0	20	60	6		
~04006R0100.020.060	~04006R0100.020.060	4,0	1,0	4,0	4,0	20	60	6		



Продолжение таблицы см. на следующей странице



Пример заказа фрез: код инструмента WM077 + код размера 01004R0010.004.050 = WM07701004R0010.004.050



СЕРИИ WM077/WM078

**(плоский торец с угловым радиусом, обнижение рабочей части,
продолжение размерного ряда)**



Артикулы		D, мм	R, мм	Допуск D, мм	Допуск R, мм	l, мм		l ₁ , мм	L, мм	d, мм			
рис. 1, z=2 WM077~	рис. 2, z=4 WM078~					z=2	z=4						
~04006R0010.025.060	~04006R0010.025.060	4,0	0,1	0 ~ -0,02	±0,015	4,0	4,0	25	60	6			
~04006R0020.025.060	~04006R0020.025.060	4,0	0,2			4,0	4,0	25	60	6			
~04006R0030.025.060	~04006R0030.025.060	4,0	0,3			4,0	4,0	25	60	6			
~04006R0050.025.060	~04006R0050.025.060	4,0	0,5			4,0	4,0	25	60	6			
~04006R0100.025.060	~04006R0100.025.060	4,0	1,0			4,0	4,0	25	60	6			
~04006R0010.030.075	~04006R0010.030.075	4,0	0,1			4,0	4,0	30	75	6			
~04006R0020.030.075	~04006R0020.030.075	4,0	0,2			4,0	4,0	30	75	6			
~04006R0030.030.075	~04006R0030.030.075	4,0	0,3			4,0	4,0	30	75	6			
~04006R0050.030.075	~04006R0050.030.075	4,0	0,5			4,0	4,0	30	75	6			
~04006R0100.030.075	~04006R0100.030.075	4,0	1,0			4,0	4,0	30	75	6			
~04006R0010.035.075	~04006R0010.035.075	4,0	0,1			4,0	4,0	35	75	6			
~04006R0020.035.075	~04006R0020.035.075	4,0	0,2			4,0	4,0	35	75	6			
~04006R0030.035.075	~04006R0030.035.075	4,0	0,3			4,0	4,0	35	75	6			
~04006R0050.035.075	~04006R0050.035.075	4,0	0,5			4,0	4,0	35	75	6			
~04006R0100.035.075	~04006R0100.035.075	4,0	1,0			4,0	4,0	35	75	6			
~05006R0010.016.060	~05006R0010.016.060	5,0	0,1			0 ~ -0,03	±0,015	5,0	5,0	16	60	6	
~05006R0020.016.060	~05006R0020.016.060	5,0	0,2					5,0	5,0	16	60	6	
~05006R0030.016.060	~05006R0030.016.060	5,0	0,3					5,0	5,0	16	60	6	
~05006R0050.016.060	~05006R0050.016.060	5,0	0,5					5,0	5,0	16	60	6	
~05006R0100.016.060	~05006R0100.016.060	5,0	1,0					5,0	5,0	16	60	6	
~05006R0010.030.075	~05006R0010.030.075	5,0	0,1					5,0	5,0	30	75	6	
~05006R0020.030.075	~05006R0020.030.075	5,0	0,2					5,0	5,0	30	75	6	
~05006R0030.030.075	~05006R0030.030.075	5,0	0,3					5,0	5,0	30	75	6	
~05006R0050.030.075	~05006R0050.030.075	5,0	0,5					5,0	5,0	30	75	6	
~05006R0100.030.075	~05006R0100.030.075	5,0	1,0					5,0	5,0	30	75	6	
~06006R0010.020.060	~06006R0010.020.060	6,0	0,1					7,0	7,0	20	60	6	
~06006R0020.020.060	~06006R0020.020.060	6,0	0,2					7,0	7,0	20	60	6	
~06006R0030.020.060	~06006R0030.020.060	6,0	0,3					7,0	7,0	20	60	6	
~06006R0050.020.060	~06006R0050.020.060	6,0	0,5					7,0	7,0	20	60	6	
~06006R0100.020.060	~06006R0100.020.060	6,0	1,0					7,0	7,0	20	60	6	
~06006R0150.020.060	~06006R0150.020.060	6,0	1,5	7,0	7,0			20	60	6			
~06006R0010.030.075	~06006R0010.030.075	6,0	0,1	7,0	7,0			30	75	6			
~06006R0020.030.075	~06006R0020.030.075	6,0	0,2	7,0	7,0			30	75	6			
~06006R0030.030.075	~06006R0030.030.075	6,0	0,3	7,0	7,0			30	75	6			
~06006R0050.030.075	~06006R0050.030.075	6,0	0,5	7,0	7,0			30	75	6			
~06006R0100.030.075	~06006R0100.030.075	6,0	1,0	7,0	7,0			30	75	6			
~06006R0150.030.075	~06006R0150.030.075	6,0	1,5	7,0	7,0			30	75	6			
~08008R0050.022.060	~08008R0050.022.060	8,0	0,5	0 ~ -0,03	±0,015			9,0	9,0	22	60	8	
~08008R0100.022.060	~08008R0100.022.060	8,0	1,0					9,0	9,0	22	60	8	
~08008R0150.022.060	~08008R0150.022.060	8,0	1,5					9,0	9,0	22	60	8	
~08008R0200.022.060	~08008R0200.022.060	8,0	2,0					±0,020	9,0	9,0	22	60	8
~10010R0050.024.075	~10010R0050.024.075	10,0	0,5					±0,015	11,0	11,0	24	75	10
~10010R0100.024.075	~10010R0100.024.075	10,0	1,0						11,0	11,0	24	75	10
~10010R0150.024.075	~10010R0150.024.075	10,0	1,5						11,0	11,0	24	75	10
~10010R0200.024.075	~10010R0200.024.075	10,0	2,0					±0,015	±0,020	11,0	11,0	24	75
~12012R0050.026.075	~12012R0050.026.075	12,0	0,5			13,0	13,0		26	75	12		
~12012R0100.026.075	~12012R0100.026.075	12,0	1,0			±0,015	13,0		13,0	26	75	12	
~12012R0150.026.075	~12012R0150.026.075	12,0	1,5			13,0	13,0		26	75	12		
~12012R0200.026.075	~12012R0200.026.075	12,0	2,0			±0,020	13,0	13,0	26	75	12		



РЕЖИМЫ РЕЗАНИЯ ДЛЯ ФРЕЗ СЕРИЙ WM077/WM078

Материалы Твердость	Углеродистые стали / Легированные стали до 35 HRC				Легированные стали / Инструментальные стали 35–45 HRC				Предварительно закаленные стали 45–55 HRC			
	N, об./мин		V _f , мм/мин		N, об./мин		V _f , мм/мин		N, об./мин		V _f , мм/мин	
D, мм	z=2	z=4	z=2	z=4	z=2	z=4	z=2	z=4	z=2	z=4	z=2	z=4
1,0	33100	—	280	—	21600	—	120	—	13200	—	70	—
1,2	30000	—	300	—	18000	—	125	—	12000	—	70	—
1,5	26400	—	300	—	16200	—	130	—	10200	—	70	—
2,0	21600	21600	310	380	13800	13800	140	280	8640	8640	80	150
2,5	18000	18000	320	390	11400	11400	150	300	7320	7320	80	150
3,0	15900	15900	330	400	10300	10300	160	310	6300	6300	80	150
4,0	12800	12800	400	500	8200	8200	200	360	5150	5150	95	160
5,0	11000	11000	500	510	7000	7000	240	430	4560	4560	120	200
6,0	9500	9500	600	510	6000	6000	300	430	3930	3930	140	200
8,0	7200	7200	640	550	4550	4550	300	430	3020	3020	140	200
10,0	6000	6000	640	550	4000	4000	300	430	2420	2420	140	200
12,0	5000	5000	500	430	3340	3340	270	380	2000	2000	120	160

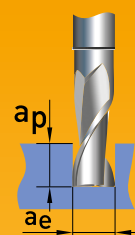

1. Необходимо стремиться к наибольшей жесткости системы СПИД.
2. В случае изменения скорости резания V_c (количества оборотов/мин, N), скорость подачи (V_f) необходимо пропорционально изменить.
3. При увеличении вылета инструмента требуется уменьшить обороты и скорость подачи.
4. Режимы резания носят исключительно рекомендательный характер. Окончательные значения режимов резания уточняются на стадии отработки конкретной технологической операции в производственных условиях.

СЕРИЯ WM066

(плоский торец с угловым радиусом, коническое обнижение рабочей части)

Фрезы твердосплавные концевые с коническим обнижением рабочей части для общей универсальной обработки материалов 25–55 HRC: углеродистых, конструкционных, легированных и термостойких сталей, нержавеющей стали, чугунов.

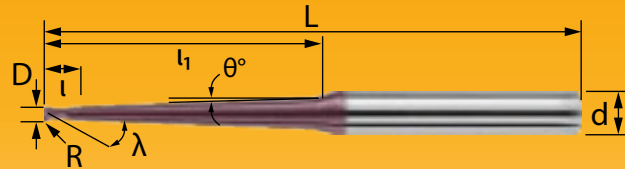

- Исполнение с высокотехнологичным покрытием AlTiCrN увеличивает износостойкость и снижает коэффициент трения.
- Различный угол конус рабочей части делает ее пригодной для различных применений.
- Применяемый малый радиус закругления предотвращает выкрашивание режущих кромок.
- Высокая прочность конической шейки позволяет прорезать глубокие канавки без поломок.



Артикул WM066~	D, мм	R, мм	Точность исполнения рабочей части, мм	Допуск R, мм	θ°	l, мм	l ₁ , мм	L, мм	d, мм
~01006R010.020.060A005N	1,0	0,10	0 ~ -0,02	±0,015	0,5°	2,0	20	60	6
~01006R010.020.060A010N	1,0	0,10			1,0°	2,0	20	60	6
~01006R010.020.060A015N	1,0	0,10			1,5°	2,0	20	60	6
~01206R012.030.075A005N	1,2	0,12			0,5°	2,0	30	75	6
~01206R012.030.075A010N	1,2	0,12			1,0°	2,0	30	75	6
~01206R012.030.075A015N	1,2	0,12			1,5°	2,0	30	75	6
~01506R015.030.075A005N	1,5	0,15			0,5°	2,0	30	75	6
~01506R015.030.075A010N	1,5	0,15			1,0°	2,0	30	75	6
~01506R015.030.075A015N	1,5	0,15			1,5°	2,0	30	75	6
~01806R018.030.075A005N	1,8	0,18			0,5°	2,0	30	75	6
~01806R018.030.075A010N	1,8	0,18			1,0°	2,0	30	75	6
~01806R018.030.075A015N	1,8	0,18			1,5°	2,0	30	75	6
~02006R020.025.075A015N	2,0	0,20			1,5°	3,0	25	75	6
~02006R020.039.075A015N	2,0	0,20			1,5°	3,0	39	75	6
~02006R050.025.075A015N	2,0	0,50			1,5°	3,0	25	75	6
~02006R050.039.075A015N	2,0	0,50			1,5°	3,0	39	75	6
~02006R050.050.100A015L	2,0	0,50			1,5°	3,0	50	100	6
~02006R050.035.075A005N	2,0	0,50			0,5°	4,0	35	75	6
~02006R050.035.075A010N	2,0	0,50			1,0°	4,0	35	75	6
~02006R050.035.075A015N	2,0	0,50			1,5°	4,0	35	75	6
~02506R050.035.075A005N	2,5	0,50			0,5°	5,0	35	75	6
~02506R050.035.075A010N	2,5	0,50			1,0°	5,0	35	75	6
~02506R050.035.075A015N	2,5	0,50			1,5°	5,0	35	75	6
~02506R100.035.075A005N	2,5	1,00			0,5°	5,0	35	75	6
~02506R100.035.075A010N	2,5	1,00			1,0°	5,0	35	75	6
~02506R100.035.075A015N	2,5	1,00			1,5°	5,0	35	75	6
~03006R050.025.075A015N	3,0	0,50			1,5°	4,5	25	75	6
~03006R100.025.075A015N	3,0	1,00			1,5°	4,5	25	75	6
~03006R100.039.075A015N	3,0	1,00			1,5°	4,5	39	75	6
~03006R100.050.100A015L	3,0	1,00			1,5°	4,5	50	100	6
~03006R050.035.075A005N	3,0	0,50	0,5°	5,0	35	75	6		
~03006R050.035.075A010N	3,0	0,50	1,0°	5,0	35	75	6		
~03006R050.035.075A015N	3,0	0,50	1,5°	5,0	35	75	6		
~03006R100.035.075A005N	3,0	1,00	0,5°	5,0	35	75	6		
~03006R100.035.075A010N	3,0	1,00	1,0°	5,0	35	75	6		
~03006R100.035.075A015N	3,0	1,00	1,5°	5,0	35	75	6		

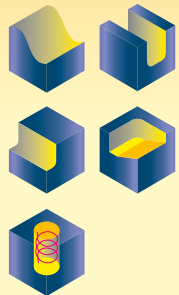

Продолжение таблицы см. на следующей странице



СЕРИЯ WM066

(плоский торец с угловым радиусом, коническое обniżение рабочей части, продолжение размерного ряда)



Артикул WM066~	D, мм	R, мм	Точность исполнения рабочей части, мм	Допуск R, мм	θ°	l, мм	l ₁ , мм	L, мм	d, мм
~03506R050.035.075A005N	3,5	0,50	0 ~ -0,02	±0,015	0,5°	5,0	35	75	6
~03506R050.035.075A010N	3,5	0,50			1,0°	5,0	35	75	6
~03506R050.035.075A015N	3,5	0,50			1,5°	5,0	35	75	6
~03506R100.035.075A005N	3,5	1,00			0,5°	5,0	35	75	6
~03506R100.035.075A010N	3,5	1,00			1,0°	5,0	35	75	6
~03506R100.035.075A015N	3,5	1,00			1,5°	5,0	35	75	6
~04006R050.045.100A005L	4,0	0,50			0,5°	6,0	45	100	6
~04006R050.045.100A010L	4,0	0,50			1,0°	6,0	45	100	6
~04006R050.025.075A015N	4,0	0,50			1,5°	6,0	25	75	6
~04006R050.045.100A015L	4,0	0,50			1,5°	6,0	45	100	6
~04006R100.045.100A005L	4,0	1,00			0,5°	6,0	45	100	6
~04006R100.045.100A010L	4,0	1,00			1,0°	6,0	45	100	6
~04006R100.025.075A015N	4,0	1,00			1,5°	6,0	25	75	6
~04006R100.045.100A015L	4,0	1,00			1,5°	6,0	45	100	6
~05006R100.025.075A015N	5,0	1,00			1,5°	7,5	25	75	6
~05008R100.050.100A015L	5,0	1,00			1,5°	7,5	50	100	8
~06008R100.035.075A015N	6,0	1,00			1,5°	9,0	35	75	8
~06010R100.050.100A015L	6,0	1,00			1,5°	9,0	50	100	10

Z=2 $\lambda=30^\circ$

AlTiCrN

MG

HRC 55



СЕРИЯ WM052 (плоский торец, коническая режущая часть)

Фрезы твердосплавные концевые с конической рабочей частью для общей универсальной обработки материалов 20–55 HRC: углеродистых, конструкционных, легированных и термоупрочненных сталей, нержавеющей сталей, чугунов.

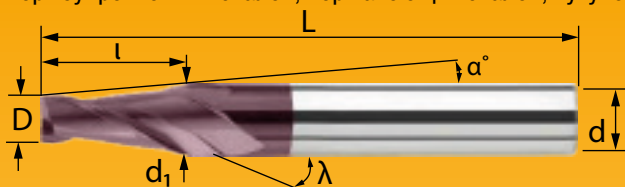

- Исполнение с высокотехнологичным покрытием AlTiCrN увеличивает износостойкость и снижает коэффициент трения.
- Высокая прочность конической режущей части позволяет формировать глубокие канавки без поломок фрезы..

Артикул	D, мм	Точность исполнения рабочей части, мм	α°	l, мм	d ₁ , мм	L, мм	d, мм
WM05200104ST200N	0,15	0 ~ -0,02	20,0°	5,29	—	42	4
WM05200304ST200N	0,30		20,0°	5,08	—	42	4
WM05200304ST250N	0,30		25,0°	3,96	—	42	4
WM05200604ST150N	0,60		15,0°	4,50	—	42	4
WM05200604ST200N	0,60		20,0°	4,67	—	42	4
WM05201204ST200N	1,20		20,0°	3,84	—	42	4
WM05201004ST005N	1,00		0,5°	4,00	1,07	50	4
WM05201004ST010N	1,00		1,0°	4,00	1,14	50	4
WM05201004ST015N	1,00		1,5°	4,00	1,21	50	4
WM05201004ST020N	1,00		2,0°	4,00	1,28	50	4
WM05201004ST025N	1,00		2,5°	4,00	1,35	50	4
WM05201004ST030N	1,00		3,0°	4,00	1,42	50	4
WM05201004ST050N	1,00		5,0°	4,00	1,70	50	4
WM05201004ST070N	1,00		7,0°	4,00	1,98	50	4
WM05201004ST100N	1,00		10,0°	4,00	2,41	50	4
WM05201004ST150N	1,00		15,0°	4,00	3,14	50	4
WM05201504ST005N	1,50		0,5°	5,00	1,59	50	4
WM05201504ST010N	1,50		1,0°	5,00	1,68	50	4
WM05201504ST015N	1,50		1,5°	5,00	1,76	50	4
WM05201504ST020N	1,50		2,0°	5,00	1,85	50	4
WM05201504ST025N	1,50		2,5°	5,00	1,93	50	4
WM05201504ST030N	1,50		3,0°	5,00	2,02	50	4
WM05201504ST050N	1,50		5,0°	5,00	2,37	50	4
WM05202004ST005N	2,00		0,5°	6,00	2,10	50	4
WM05202004ST010N	2,00		1,0°	6,00	2,21	50	4
WM05202004ST015N	2,00		1,5°	6,00	2,31	50	4
WM05202004ST020N	2,00		2,0°	6,00	2,41	50	4
WM05202004ST025N	2,00		2,5°	6,00	2,52	50	4
WM05202004ST030N	2,00		3,0°	6,00	2,62	50	4
WM05202004ST050N	2,00		5,0°	6,00	3,05	50	4
WM05202004ST070N	2,00		7,0°	6,00	3,47	50	4
WM05202006ST100N	2,00		10,0°	6,00	4,11	50	6
WM05202006ST150N	2,00		15,0°	6,00	5,22	50	6
WM05202504ST005N	2,50	0,5°	8,00	2,64	50	4	
WM05202504ST010N	2,50	1,0°	8,00	2,78	50	4	
WM05202504ST015N	2,50	1,5°	8,00	2,91	50	4	
WM05202504ST020N	2,50	2,0°	8,00	3,05	50	4	
WM05202504ST025N	2,50	2,5°	8,00	3,20	50	4	
WM05202504ST030N	2,50	3,0°	8,00	3,33	50	4	
WM05202504ST050N	2,50	5,0°	8,00	3,90	50	4	

Z=2 λ=35°

AlTiCrN MG

HRC 55

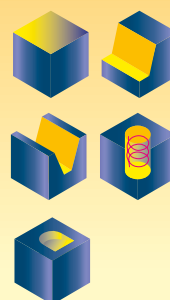

Продолжение таблицы см. на следующей странице



СЕРИЯ WM052 (плоский торец, коническая режущая часть, продолжение размерного ряда)



Артикул	D, мм	Точность исполнения рабочей части, мм	α°	l, мм	d ₁ , мм	L, мм	d, мм		
WM05203006ST005N	3,00	0 ~ -0,02	0,5°	10,00	3,17	50	6		
WM05203006ST010N	3,00		1,0°	10,00	3,35	50	6		
WM05203006ST015N	3,00		1,5°	10,00	3,52	50	6		
WM05203006ST020N	3,00		2,0°	10,00	3,69	50	6		
WM05203006ST025N	3,00		2,5°	10,00	3,87	50	6		
WM05203006ST030N	3,00		3,0°	10,00	4,05	50	6		
WM05203006ST050N	3,00		5,0°	10,00	4,75	50	6		
WM05203006ST070N	3,00		7,0°	12,00	6,00	50	6		
WM05203008ST100N	3,00		10,0°	12,00	7,22	60	8		
WM05203010ST150N	3,00		15,0°	12,00	9,40	75	10		
WM05204006ST005N	4,00		0 ~ -0,02	0,5°	15,00	4,26	50	6	
WM05204006ST010N	4,00			1,0°	15,00	4,52	50	6	
WM05204006ST015N	4,00			1,5°	15,00	4,79	50	6	
WM05204006ST020N	4,00			2,0°	15,00	5,04	50	6	
WM05204006ST025N	4,00			2,5°	15,00	5,31	50	6	
WM05204006ST030N	4,00			3,0°	15,00	5,57	50	6	
WM05204008ST050N	4,00			5,0°	15,00	6,62	60	8	
WM05204008ST070N	4,00			7,0°	16,00	8,00	60	8	
WM05204010ST100N	4,00			10,0°	17,00	10,00	75	10	
WM05204012ST150N	4,00			15,0°	14,90	12,00	75	12	
WM05205006ST005N	5,00	0 ~ -0,02		0,5°	20,00	5,34	60	6	
WM05205006ST010N	5,00			1,0°	20,00	5,70	60	6	
WM05205006ST015N	5,00			1,5°	19,60	6,00	60	6	
WM05205008ST020N	5,00			2,0°	20,00	6,39	60	8	
WM05205008ST025N	5,00			2,5°	20,00	6,74	60	8	
WM05205008ST030N	5,00			3,0°	20,00	7,10	60	8	
WM05205010ST050N	5,00			5,0°	20,00	8,50	75	10	
WM05205010ST070N	5,00			7,0°	20,00	10,00	75	10	
WM05205012ST100N	5,00			10,0°	20,00	12,00	75	12	
WM05206008ST005N	6,00			0 ~ -0,03	0,5°	20,00	6,35	60	8
WM05206008ST010N	6,00		1,0°		20,00	6,70	60	8	
WM05206008ST015N	6,00		1,5°		20,00	7,05	60	8	
WM05206008ST020N	6,00		2,0°		20,00	7,40	60	8	
WM05206008ST025N	6,00		2,5°		20,00	7,75	60	8	
WM05206010ST030N	6,00		3,0°		20,00	8,10	75	10	
WM05206010ST050N	6,00		5,0°		20,00	9,50	75	10	
WM05206012ST070N	6,00		7,0°		24,00	12,00	75	12	
WM05206014ST100N	6,00		10,0°		22,00	14,00	75	14	
WM05208010ST005N	8,00		0 ~ -0,03		0,5°	25,00	8,44	75	10
WM05208010ST010N	8,00				1,0°	25,00	8,87	75	10
WM05208010ST015N	8,00	1,5°			25,00	9,31	75	10	
WM05208010ST020N	8,00	2,0°			25,00	9,75	75	10	
WM05208012ST030N	8,00	3,0°			25,00	10,62	75	12	
WM05208014ST050N	8,00	5,0°			25,00	12,37	75	14	
WM05208016ST070N	8,00	7,0°			32,00	16,00	100	16	
WM05208018ST100N	8,00	10,0°			28,00	18,00	100	18	
WM05210012ST005N	10,00	0 ~ -0,03			0,5°	35,00	10,61	75	12
WM05210012ST010N	10,00				1,0°	35,00	11,22	75	12
WM05210012ST015N	10,00				1,5°	35,00	11,83	75	12
WM05210014ST020N	10,00			2,0°	35,00	12,44	75	14	
WM05210014ST030N	10,00			3,0°	35,00	13,67	75	14	
WM05210016ST050N	10,00			5,0°	34,20	16,00	100	16	

Z=2 λ=35°

AlTiCrN MG

HRC 55

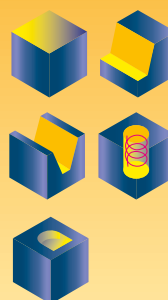

РЕЖИМЫ РЕЗАНИЯ ДЛЯ ФРЕЗ СЕРИИ WM052

Материалы	Легированные стали / Инструментальные стали						Закаленные стали		Нержавеющие стали		Чугуны	
	HRC < 20		20–30 HRC		30–40 HRC		45–55 HRC		—		—	
V_c	88 м/мин		71 м/мин		59 м/мин		35 м/мин		71 м/мин		103 м/мин	
D, мм	N, об./мин	V_f , мм/мин	N, об./мин	V_f , мм/мин	N, об./мин	V_f , мм/мин	N, об./мин	V_f , мм/мин	N, об./мин	V_f , мм/мин	N, об./мин	V_f , мм/мин
1	26000	190	22230	140	18720	100	10400	40	22230	165	32760	240
2	14040	235	11232	160	9360	110	5616	45	11232	185	16380	270
3	9828	270	7488	175	6084	120	3900	55	7488	205	11232	310
4	7020	260	5616	175	4680	120	2808	50	5616	205	8424	310
5	5850	270	4446	175	3744	120	2340	55	4446	205	6552	300
6	4680	260	3744	175	3042	120	1872	50	3744	205	5616	310
8	3510	260	2808	175	2340	120	1404	50	2808	205	4212	310
10	2808	260	2223	175	1872	120	1131	50	2223	205	3276	300

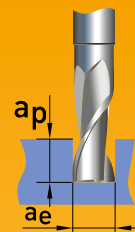

$$Ad = 0,1D$$

$$(D < 3,$$

$$Ad \leq 0,05D)$$

$$Ad = 0,5D$$

$$(D < 3, Ad \leq 0,25D)$$

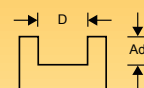

1. Необходимо стремиться к наибольшей жесткости системы СПИД.
2. В случае изменения скорости резания V_c (количества оборотов/мин, N), скорость подачи (V_f) необходимо пропорционально изменить.
3. При увеличении вылета инструмента требуется уменьшить обороты и скорость подачи.
4. Режимы резания носят исключительно рекомендательный характер. Окончательные значения режимов резания уточняются на стадии отработки конкретной технологической операции в производственных условиях.

СЕРИЯ WM043 (плоский торец)



Фрезы трехзубые из микрозернистого твердого сплава для общей универсальной обработки материалов твердостью 20–55 HRC: сталей, легированных сталей, жаропрочных сталей, нержавеющей сталей, серых чугунов.

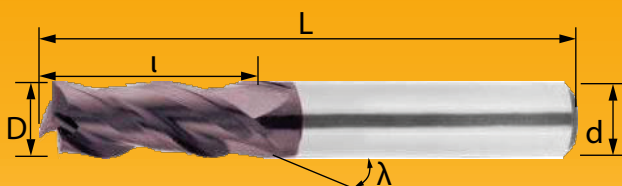

- Высокотехнологичное износостойкое покрытие AlTiCrN снижает трение и увеличивает стойкость фрез,
- Конструкция с прочной геометрией обладает отличной режущей способностью режущих кромок.
- Высокоточное боковое фрезерование.

Артикул	D, мм	Точность исполнения рабочей части, мм	l, мм	L, мм	d, мм
WM04301003S0000N	1,0	0 ~ -0,02	3	50	3
WM04301004S0000N	1,0		3	50	4
WM04301503S0000N	1,5		4	50	3
WM04301504S0000N	1,5		4	50	4
WM04302003S0000N	2,0		5	50	3
WM04302004S0000N	2,0		5	50	4
WM04302504S0000N	2,5		6	50	4
WM04303003S0000N	3,0		8	50	3
WM04303004S0000N	3,0		8	50	4
WM04303006S0000N	3,0		8	50	6
WM04303504S0000N	3,5		9	50	4
WM04303506S0000N	3,5		9	50	6
WM04304004S0000N	4,0		10	50	4
WM04304006S0000N	4,0		10	50	6
WM04304506S0000N	4,5	11	50	6	
WM04305006S0000N	5,0	13	50	6	
WM04305506S0000N	5,5	14	50	6	
WM04306006S0000N	6,0	15	50	6	
WM04306508S0000N	6,5	16	60	8	
WM04307008S0000N	7,0	18	60	8	
WM04308008S0000N	8,0	20	60	8	
WM04309010S0000N	9,0	22	75	10	
WM04310010S0000N	10,0	25	75	10	
WM04311012S0000N	11,0	25	75	12	
WM04312012S0000N	12,0	30	75	12	
WM04314014S0000N	14,0	30	75	14	
WM04316016S0000N	16,0	40	100	16	
WM04318020S0000N	18,0	40	100	20	
WM04320020S0000N	20,0	45	100	20	
WM04325025S0000N	25,0	45	100	25	

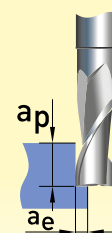
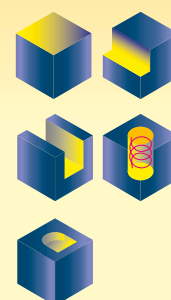

РЕЖИМЫ РЕЗАНИЯ ДЛЯ ФРЕЗ СЕРИИ WM043

Материалы	Углеродистые стали / Легированные стали				Легированные стали / Инструментальные стали				Предварительно закаленные стали				Закаленные стали				Нержавеющие стали				Чугуны			
	Твердость 180–250 НВ				Твердость 25–35 HRC				Твердость 35–45 HRC				Твердость 40–55 HRC				Твердость 79 м/мин				Твердость 120 м/мин			
D, мм	V _c 120 м/мин				V _c 95 м/мин				V _c 79 м/мин				V _c 48 м/мин				V _c 79 м/мин				V _c 120 м/мин			
	N, об./мин	V _f , мм/мин	a _p , мм	a _e , мм	N, об./мин	V _f , мм/мин	a _p , мм	a _e , мм	N, об./мин	V _f , мм/мин	a _p , мм	a _e , мм	N, об./мин	V _f , мм/мин	a _p , мм	a _e , мм	N, об./мин	V _f , мм/мин	a _p , мм	a _e , мм	N, об./мин	V _f , мм/мин	a _p , мм	a _e , мм
3	12700	762	3	0,15	10000	600	3	0,15	8386	503	3	0,15	5095	305	3	0,15	8386	503	3	0,15	12700	503	3	0,15
4	9550	764	4	0,20	7560	604	4	0,20	6290	503	4	0,20	3820	305	4	0,20	6290	503	4	0,20	9550	503	4	0,20
6	6370	890	6	0,30	5040	705	6	0,30	4200	588	6	0,30	2548	356	6	0,30	4200	588	6	0,30	6370	588	6	0,30
8	4770	668	8	0,40	3780	529	8	0,40	3140	440	8	0,40	1910	267	8	0,40	3140	440	8	0,40	4770	440	8	0,40
10	3820	458	10	0,50	3020	362	10	0,50	2515	301	10	0,50	1528	183	10	0,50	2515	301	10	0,50	3820	301	10	0,50
12	3180	380	12	0,60	2520	302	12	0,60	2100	252	12	0,60	1274	152	12	0,60	2100	252	12	0,60	3180	252	12	0,60

1. Необходимо стремиться к наибольшей жесткости системы СПИД.
2. В случае изменения скорости резания V_c (количества оборотов/мин, N), скорость подачи (V_f) необходимо пропорционально изменить.
3. При увеличении вылета инструмента требуется уменьшить обороты и скорость подачи.
4. Режимы резания носят исключительно рекомендательный характер. Окончательные значения режимов резания уточняются на стадии отработки конкретной технологической операции в производственных условиях.

СЕРИИ WM051/WM064

(плоский торец без углового радиуса и с угловым радиусом)

Фрезы двузубые из микрозернистого твердого сплава для общей универсальной обработки материалов твердостью 20–55 HRC: сталей, легированных сталей, жаропрочных сталей, нержавеющей сталей, серых чугунов. Возможна обработка материалов группы S.



рис. 1 WM051~



рис. 2 WM064~

- Исполнение с высокотехнологичным покрытием AlTiCrN увеличивает износостойкость и снижает коэффициент трения.
- Длина режущей части примерно $1 \times D$.
- Угловой радиус защищает режущую кромку от выкрашивания и позволяет осуществлять профильное фрезерование.
- Короткая режущая часть с высокой жесткостью позволяет фрезеровать с высокой подачей.
- Для штампов, пресс-форм, механических и электронных деталей из стали.
- Хорошо подходит для отделки поверхности.

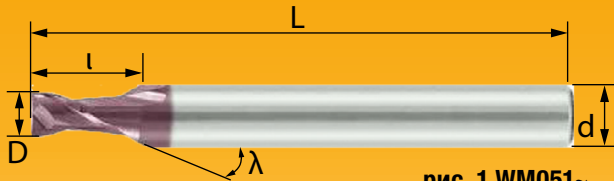
Артикулы		D, мм	R, мм	Поле допуска R, мм	Точность исполнения рабочей части, мм	l, мм	L, мм	d, мм
рис. 1 WM051~	рис. 2 WM064~							
WM05100204S0000N	—	0,2	—	—	0 ~ -0,02	0,3	50	4
WM05100304S0000N	—	0,3	—			0,4	50	4
WM05100404S0000N	—	0,4	—			0,5	50	4
WM05100504S0000N	—	0,5	—			0,6	50	4
WM05100604S0000N	—	0,6	—			0,7	50	4
WM05100704S0000N	—	0,7	—			0,8	50	4
WM05100804S0000N	—	0,8	—			1,0	50	4
WM05100904S0000N	—	0,9	—			1,1	50	4
WM05101004S0000N	—	1,0	—			1,2	50	4
—	WM06401004R0010N	1,0	0,1			± 0,015	1,0	50
—	WM06401004R0020N	1,0	0,2	1,0	50		4	
—	WM06401004R0030N	1,0	0,3	1,0	50		4	
WM05101204S0000N	—	1,2	—	—	0 ~ -0,02	1,5	50	4
—	WM06401204R0010N	1,2	0,1			1,2	50	4
—	WM06401204R0020N	1,2	0,2			1,2	50	4
—	WM06401204R0030N	1,2	0,3			1,2	50	4
WM05101404S0000N	—	1,4	—	—	0 ~ -0,02	1,8	50	4
WM05101504S0000N	—	1,5	—			1,8	50	4
—	WM06401504R0010N	1,5	0,1			1,5	50	4
—	WM06401504R0020N	1,5	0,2			1,5	50	4
—	WM06401504R0030N	1,5	0,3			1,5	50	4
—	WM06401504R0050N	1,5	0,5	1,5	50	4		
WM05101604S0000N	—	1,6	—	—	0 ~ -0,02	1,9	50	4
WM05101804S0000N	—	1,8	—			2,0	50	4
WM05102004S0000N	—	2,0	—			2,5	50	4
—	WM06402004R0010N	2,0	0,1			2,0	50	4
—	WM06402004R0020N	2,0	0,2			2,0	50	4
—	WM06402004R0030N	2,0	0,3			2,0	50	4
—	WM06402004R0050N	2,0	0,5	2,0	50	4		
WM05102504S0000N	—	2,5	—	—	0 ~ -0,02	3,0	50	4
—	WM06402504R0010N	2,5	0,1			2,5	50	4
—	WM06402504R0020N	2,5	0,2			2,5	50	4
—	WM06402504R0030N	2,5	0,3			2,5	50	4
—	WM06402504R0050N	2,5	0,5			2,5	50	4

рис. 1 WM051~

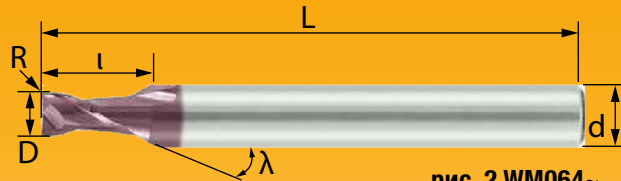

рис. 2 WM064~



Продолжение таблицы см. на следующей странице

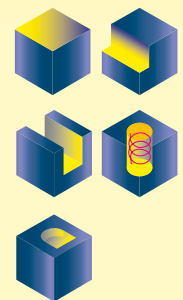
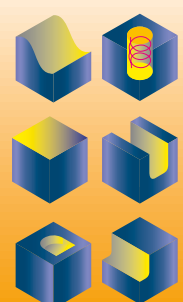

СЕРИИ WM051/WM064
(плоский торец без углового радиуса и с угловым радиусом,
продолжение размерного ряда)



Артикулы		D, мм	R, мм	Поле допуска R, мм	Точность исполнения рабочей части, мм	l, мм	L, мм	d, мм
рис. 1 WM051~	рис. 2 WM064~							
WM05103006S0000N	—	3,0	—	—	0 ~ -0,02	3,5	50	6
—	WM06403006R0010N	3,0	0,1	± 0,020		3,0	50	6
—	WM06403006R0020N	3,0	0,2			3,0	50	6
—	WM06403006R0030N	3,0	0,3			3,0	50	6
—	WM06403006R0050N	3,0	0,5			3,0	50	6
—	WM06403006R0100N	3,0	1,0			3,0	50	6
WM05104006S0000N	—	4,0	—			—	4,5	50
—	WM06404006R0010N	4,0	0,1	± 0,020		4,0	50	6
—	WM06404006R0020N	4,0	0,2			4,0	50	6
—	WM06404006R0030N	4,0	0,3			4,0	50	6
—	WM06404006R0050N	4,0	0,5			4,0	50	6
—	WM06404006R0100N	4,0	1,0			4,0	50	6
WM05105006S0000N	—	5,0	—			—	7,0	50
—	WM06405006R0010N	5,0	0,1	± 0,020		5,0	50	6
—	WM06405006R0020N	5,0	0,2			5,0	50	6
—	WM06405006R0030N	5,0	0,3			5,0	50	6
—	WM06405006R0050N	5,0	0,5			5,0	50	6
—	WM06405006R0100N	5,0	1,0			5,0	50	6
WM05106006S0000N	—	6,0	—			—	9,0	50
—	WM06406006R0010N	6,0	0,1	± 0,020		7,0	50	6
—	WM06406006R0020N	6,0	0,2			7,0	50	6
—	WM06406006R0030N	6,0	0,3			7,0	50	6
—	WM06406006R0050N	6,0	0,5			7,0	50	6
—	WM06406006R0100N	6,0	1,0			7,0	50	6
—	WM06406006R0150N	6,0	1,5		7,0	50	6	

Z=2 λ=30°

AlTiCrN MG

HRC 55



рис. 1
WM051~



рис. 2
WM064~

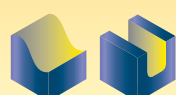

РЕЖИМЫ РЕЗАНИЯ ДЛЯ ФРЕЗ СЕРИЙ WM051/WM064

Материал	Применение	a _e , мм	a _p , мм	V _c , м/мин	f _z , мм/з					
					1 мм	2 мм	3 мм	4 мм	5 мм	6 мм
Углеродистые стали	Обработка пазов	1×D	≤ 0,5×D	50–90	0,007	0,013	0,018	0,024	0,030	0,036
	Обработка уступов	≤ 0,3×D	≤ 0,3×D	55–100	0,007	0,013	0,018	0,024	0,030	0,036
	Контурная обработка	≤ 0,3×D	≤ 0,1×D	80–135	0,007	0,013	0,018	0,024	0,030	0,036
Легированные стали / Инструментальные стали	Обработка пазов	1×D	≤ 0,5×D	40–70	0,006	0,012	0,017	0,022	0,028	0,033
	Обработка уступов	≤ 0,3×D	≤ 0,3×D	40–80	0,006	0,012	0,017	0,022	0,028	0,033
	Контурная обработка	≤ 0,3×D	≤ 0,1×D	55–100	0,006	0,012	0,017	0,022	0,028	0,033
Нержавеющие стали	Обработка пазов	1×D	≤ 0,5×D	30–40	0,006	0,011	0,015	0,020	0,025	0,030
	Обработка уступов	≤ 0,3×D	≤ 0,3×D	40–60	0,006	0,011	0,015	0,020	0,025	0,030
	Контурная обработка	≤ 0,3×D	≤ 0,1×D	50–70	0,006	0,011	0,015	0,020	0,025	0,030
Закаленные стали / Жаропрочные сплавы	Обработка пазов	1×D	≤ 0,5×D	20–40	0,005	0,010	0,014	0,018	0,023	0,027
	Обработка уступов	≤ 0,3×D	≤ 0,3×D	30–55	0,005	0,010	0,014	0,018	0,023	0,027
	Контурная обработка	≤ 0,3×D	≤ 0,1×D	40–70	0,005	0,010	0,014	0,018	0,023	0,027

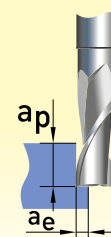

1. Необходимо стремиться к наибольшей жесткости системы СПИД.
2. В случае изменения скорости резания V_c (количества оборотов/мин, N), скорость подачи (V_f) необходимо пропорционально изменить.
3. При увеличении вылета инструмента требуется уменьшить обороты и скорость подачи.
4. Режимы резания носят исключительно рекомендательный характер. Окончательные значения режимов резания уточняются на стадии отработки конкретной технологической операции в производственных условиях.

СЕРИИ WM153/WM065

(плоский торец без углового радиуса и с угловым радиусом)

Фрезы четырехзубые из микрочернистого твердого сплава для общей универсальной обработки материалов твердостью 20–55 HRC: сталей, легированных сталей, жаропрочных сталей, нержавеющей сталей, серых чугунов. Возможна обработка материалов группы S.



рис. 1 WM153~



рис. 2 WM065~

- Исполнение с высокотехнологичным покрытием AlTiCrN увеличивает износостойкость и снижает коэффициент трения.
- Длина режущей части примерно 1×D.
- Угловой радиус защищает режущую кромку от выкрашивания и позволяет осуществлять профильное фрезерование.
- Короткая режущая часть с высокой жесткостью позволяет фрезеровать с высокой подачей.
- Для штампов, пресс-форм, механических и электронных деталей из стали.
- Хорошо подходит для отделки поверхности.

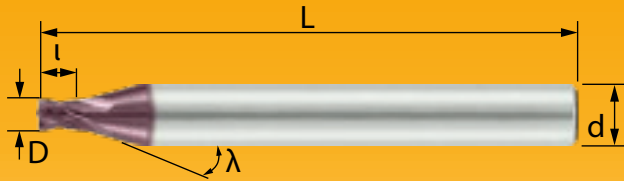
Артикулы		D, мм	R, мм	Точность исполнения рабочей части, мм	Допуск R, мм	l, мм	L, мм	d, мм
рис. 1, WM153~	рис. 2, WM065~							
~01004S0000N	—	1,0	—	0 ~ -0,02	—	1,0	50	4
~01504S0000N	—	1,5	—		—	1,5	50	4
~02004S0000N	—	2,0	—		—	2,0	50	4
—	~02004R0010N	2,0	0,1		± 0,015	2,0	50	4
—	~02004R0020N	2,0	0,2		± 0,015	2,0	50	4
—	~02004R0030N	2,0	0,3		± 0,015	2,0	50	4
—	~02004R0050N	2,0	0,5		± 0,015	2,0	50	4
~02504S0000N	—	2,5	—		—	2,5	50	4
—	~02504R0010N	2,5	0,1		± 0,015	2,5	50	4
—	~02504R0020N	2,5	0,2		± 0,015	2,5	50	4
—	~02504R0030N	2,5	0,3		± 0,015	2,5	50	4
—	~02504R0050N	2,5	0,5		± 0,015	2,5	50	4
~03006S0000N	—	3,0	—		—	3,0	50	6
—	~03006R0010N	3,0	0,1		± 0,015	3,0	50	6
—	~03006R0020N	3,0	0,2		± 0,015	3,0	50	6
—	~03006R0030N	3,0	0,3		± 0,015	3,0	50	6
—	~03006R0050N	3,0	0,5		± 0,015	3,0	50	6
—	~03006R0100N	3,0	1,0		± 0,015	3,0	50	6
~04006S0000N	—	4,0	—	—	4,0	50	6	
—	~04006R0010N	4,0	0,1	± 0,015	4,0	50	6	
—	~04006R0020N	4,0	0,2	± 0,015	4,0	50	6	
—	~04006R0030N	4,0	0,3	± 0,015	4,0	50	6	
—	~04006R0050N	4,0	0,5	± 0,015	4,0	50	6	
—	~04006R0100N	4,0	1,0	± 0,015	4,0	50	6	
~05006S0000N	—	5,0	—	—	5,0	50	6	
—	~05006R0010N	5,0	0,1	± 0,015	5,0	50	6	
—	~05006R0020N	5,0	0,2	± 0,015	5,0	50	6	
—	~05006R0030N	5,0	0,3	± 0,015	5,0	50	6	
—	~05006R0050N	5,0	0,5	± 0,015	5,0	50	6	
—	~05006R0100N	5,0	1,0	± 0,015	5,0	50	6	
~06006S0000N	—	6,0	—	—	6,0	50	6	
—	~06006R0010N	6,0	0,1	± 0,015	7,0	50	6	
—	~06006R0020N	6,0	0,2	± 0,015	7,0	50	6	
—	~06006R0030N	6,0	0,3	± 0,015	7,0	50	6	
—	~06006R0050N	6,0	0,5	± 0,015	7,0	50	6	
—	~06006R0100N	6,0	1,0	± 0,015	7,0	50	6	
—	~06006R0150N	6,0	1,5	± 0,015	7,0	50	6	

рис. 1 WM153~

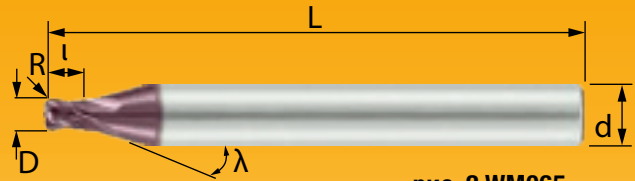
рис. 2 WM065~

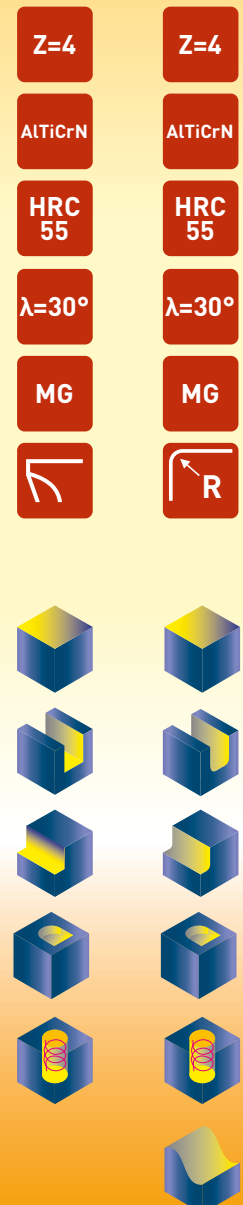

Пример заказа фрез: код инструмента WM153 + код размера 01004S0000N = WM15301004S0000N

РЕЖИМЫ РЕЗАНИЯ ДЛЯ ФРЕЗ СЕРИЙ WM153 И WM065

Материал	Применение	a_e , мм	a_p , мм	V_c , м/мин	f_z , мм/з					
					1 мм	2 мм	3 мм	4 мм	5 мм	6 мм
Углеродистые стали	Обработка пазов	$1 \times D$	$\leq 0,5 \times D$	50–90	0,007	0,013	0,018	0,024	0,030	0,036
	Обработка уступов	$\leq 0,3 \times D$	$\leq 0,3 \times D$	55–100	0,007	0,013	0,018	0,024	0,030	0,036
	Контурная обработка	$\leq 0,3 \times D$	$\leq 0,1 \times D$	80–135	0,007	0,013	0,018	0,024	0,030	0,036
Легированные стали / Инструментальные стали	Обработка пазов	$1 \times D$	$\leq 0,5 \times D$	40–70	0,006	0,012	0,017	0,022	0,028	0,033
	Обработка уступов	$\leq 0,3 \times D$	$\leq 0,3 \times D$	40–80	0,006	0,012	0,017	0,022	0,028	0,033
	Контурная обработка	$\leq 0,3 \times D$	$\leq 0,1 \times D$	55–100	0,006	0,012	0,017	0,022	0,028	0,033
Нержавеющие стали	Обработка пазов	$1 \times D$	$\leq 0,5 \times D$	30–40	0,006	0,011	0,015	0,020	0,025	0,030
	Обработка уступов	$\leq 0,3 \times D$	$\leq 0,3 \times D$	40–60	0,006	0,011	0,015	0,020	0,025	0,030
	Контурная обработка	$\leq 0,3 \times D$	$\leq 0,1 \times D$	50–70	0,006	0,011	0,015	0,020	0,025	0,030
Закаленные стали / Жаропрочные сплавы	Обработка пазов	$1 \times D$	$\leq 0,5 \times D$	20–40	0,005	0,010	0,014	0,018	0,023	0,027
	Обработка уступов	$\leq 0,3 \times D$	$\leq 0,3 \times D$	30–55	0,005	0,010	0,014	0,018	0,023	0,027
	Контурная обработка	$\leq 0,3 \times D$	$\leq 0,1 \times D$	40–70	0,005	0,010	0,014	0,018	0,023	0,027



1. Необходимо стремиться к наибольшей жесткости системы СПИД.
2. В случае изменения скорости резания V_c (количества оборотов/мин, N), скорость подачи (V_f) необходимо пропорционально изменить.
3. При увеличении вылета инструмента требуется уменьшить обороты и скорость подачи.
4. Режимы резания носят исключительно рекомендательный характер. Окончательные значения режимов резания уточняются на стадии отработки конкретной технологической операции в производственных условиях.

СЕРИИ WM046/WM047 (плоский торец)



Фрезы шестизубые из микрочернистого твердого сплава для общей универсальной обработки материалов твердостью 20–55 HRC: сталей, легированных сталей, жаропрочных сталей, Возможна обработка нержавеющей сталей, серых чугунов и FRP.



- Исполнение с высокотехнологичным покрытием AlTiCrN увеличивает износостойкость и снижает коэффициент трения.
- Высокая режущая способность способствует увеличению скорости и подачи, а также более высокому удельному съему материала.
- Прочная спиральная конструкция обеспечивает высокую скорость фрезерования.
- Шесть зубьев способствуют получению высококачественной поверхности.

Артикулы		D, мм	Точность исполнения рабочей части, мм	l, мм	L, мм	d, мм
рис. 1, WM046~	рис. 2, WM047~					
WM04606060S0000N	—	6	0 ~ -0,02	15	50	6
—	WM04706060S0000L	6	0 ~ -0,03	30	75	6
WM04608080S0000N	—	8	0 ~ -0,03	20	60	8
—	WM04708080S0000L	8	0 ~ -0,04	35	100	8
WM04610010S0000N	—	10	0 ~ -0,03	25	75	10
—	WM04710010S0000L	10	0 ~ -0,04	45	100	10
WM04612012S0000N	—	12	0 ~ -0,03	30	75	12
—	WM04712012S0000L	12	0 ~ -0,04	45	100	12
—	WM04716016S0000L	16	0 ~ -0,05	70	150	16

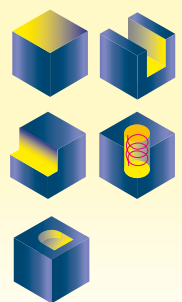

РЕЖИМЫ РЕЗАНИЯ ДЛЯ ФРЕЗ СЕРИИ WM046



Материалы	Углеродистые стали / Легированные стали				Легированные стали / Инструментальные стали				Предварительно закаленные стали				Закаленные стали				Нержавеющие стали				Чугуны			
Твердость	180–250 НВ				25–35 HRC				35–45 HRC				40–55 HRC											
V_c	120 м/мин				95 м/мин				79 м/мин				48 м/мин				79 м/мин				120 м/мин			
D, мм	N, об./мин	V_f , мм/мин	a_p , мм	a_e , мм	N, об./мин	V_f , мм/мин	a_p , мм	a_e , мм	N, об./мин	V_f , мм/мин	a_p , мм	a_e , мм	N, об./мин	V_f , мм/мин	a_p , мм	a_e , мм	N, об./мин	V_f , мм/мин	a_p , мм	a_e , мм	N, об./мин	V_f , мм/мин	a_p , мм	a_e , мм
3	12700	762	4,5	0,15	10000	600	4,5	0,15	8386	503	4,5	0,15	5095	305	4,5	0,15	7430	743	4,5	0,15	12700	503	4,5	0,15
4	9550	764	6,0	0,20	7560	604	6,0	0,20	6290	503	6,0	0,20	3820	305	6,0	0,20	5570	577	6,0	0,20	9550	503	6,0	0,20
6	6370	890	9,0	0,30	5040	705	9,0	0,30	4200	588	9,0	0,30	2548	356	9,0	0,30	3720	595	9,0	0,30	6370	588	9,0	0,30
8	4770	668	12,0	0,40	3780	529	12,0	0,40	3140	440	12,0	0,40	1910	267	12,0	0,40	2780	556	12,0	0,40	4770	440	12,0	0,40
10	3820	458	15,0	0,50	3020	362	15,0	0,50	2515	301	15,0	0,50	1528	183	15,0	0,50	2230	535	15,0	0,50	3820	301	15,0	0,50
12	3180	380	18,0	0,60	2520	302	18,0	0,60	2100	252	18,0	0,60	1274	152	18,0	0,60	1860	484	18,0	0,60	3180	252	18,0	0,60

РЕЖИМЫ РЕЗАНИЯ ДЛЯ ФРЕЗ СЕРИИ WM047

Материалы	Углеродистые стали / Легированные стали				Легированные стали / Инструментальные стали				Предварительно закаленные стали				Закаленные стали				Нержавеющие стали				Чугуны			
Твердость	180–250 НВ				25–35 HRC				35–45 HRC				40–55 HRC											
V_c	96 м/мин				76 м/мин				63 м/мин				38 м/мин				63 м/мин				96 м/мин			
D, мм	N, об./мин	V_f , мм/мин	a_p , мм	a_e , мм	N, об./мин	V_f , мм/мин	a_p , мм	a_e , мм	N, об./мин	V_f , мм/мин	a_p , мм	a_e , мм	N, об./мин	V_f , мм/мин	a_p , мм	a_e , мм	N, об./мин	V_f , мм/мин	a_p , мм	a_e , мм	N, об./мин	V_f , мм/мин	a_p , мм	a_e , мм
3	10160	610	4,5	0,15	8000	480	4,5	0,15	67010	402	4,5	0,15	4076	244	4,5	0,15	5944	594	4,5	0,15	10160	402	4,5	0,15
4	7640	611	6,0	0,20	6048	483	6,0	0,20	5032	402	6,0	0,20	3056	244	6,0	0,20	4456	462	6,0	0,20	7640	402	6,0	0,20
6	5096	712	9,0	0,30	4032	564	9,0	0,30	3360	470	9,0	0,30	2040	285	9,0	0,30	2976	476	9,0	0,30	5096	470	9,0	0,30
8	3816	534	12,0	0,40	3024	423	12,0	0,40	2512	352	12,0	0,40	1528	214	12,0	0,40	2224	445	12,0	0,40	3816	352	12,0	0,40
10	3056	366	15,0	0,50	2416	290	15,0	0,50	2012	241	15,0	0,50	1220	146	15,0	0,50	1784	428	15,0	0,50	3056	241	15,0	0,50
12	2544	304	18,0	0,60	2016	242	18,0	0,60	1680	202	18,0	0,60	1020	122	18,0	0,60	1488	387	18,0	0,60	2544	202	18,0	0,60

1. Необходимо стремиться к наибольшей жесткости системы СПИД.
2. В случае изменения скорости резания V_c (количества оборотов/мин, N), скорость подачи (V_f) необходимо пропорционально изменить.
3. При увеличении вылета инструмента требуется уменьшить обороты и скорость подачи.
4. Режимы резания носят исключительно рекомендательный характер. Окончательные значения режимов резания уточняются на стадии отработки конкретной технологической операции в производственных условиях.



8.2. ФРЕЗЫ СО СФЕРИЧЕСКИМ ТОРЦОМ

СЕРИЯ WM076 (сферический торец, обнижение рабочей части)

Фрезы твердосплавные концевые с обнижением рабочей части для общей универсальной обработки материалов 35–55 HRC: углеродистых, конструкционных, легированных и термоупрочненных сталей, нержавеющей сталей, чугунов, меди, FRP.

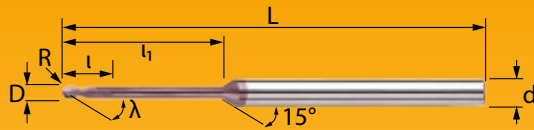
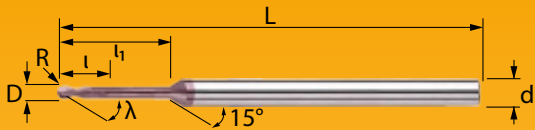

- Высокопроизводительная геометрия и прочная конструкция спирали позволяют работать на повышенной скорости резания, с более высокой скоростью подачи, что увеличивает объем удаляемого материала и ведет к повышению производительности.
- Исполнение с высокотехнологичным покрытием AlTiCrN увеличивает износостойкость и снижает коэффициент трения.
- Широкий диапазон рабочей длины.
- Применяется для глубокой обработки.

Артикул	D, мм	R, мм	Допуск R, мм	l, мм	l ₁ , мм	L, мм	d, мм
WM07600304B0015.001.050	0,3	0,15	±0,015	0,3	1	50	4
WM07600304B0015.002.050	0,3	0,15		0,3	2	50	4
WM07600304B0015.003.050	0,3	0,15		0,3	3	50	4
WM07600404B0020.001.050	0,4	0,20		0,4	1	50	4
WM07600404B0020.002.050	0,4	0,20		0,4	2	50	4
WM07600404B0020.003.050	0,4	0,20		0,4	3	50	4
WM07600404B0020.004.050	0,4	0,20		0,4	4	50	4
WM07600404B0020.005.050	0,4	0,20		0,4	5	50	4
WM07600404B0020.006.050	0,4	0,20		0,4	6	50	4
WM07600404B0020.008.050	0,4	0,20		0,4	8	50	4
WM07600504B0025.001.050	0,5	0,25		0,5	1	50	4
WM07600504B0025.002.050	0,5	0,25		0,5	2	50	4
WM07600504B0025.003.050	0,5	0,25		0,5	3	50	4
WM07600504B0025.004.050	0,5	0,25		0,5	4	50	4
WM07600504B0025.005.050	0,5	0,25		0,5	5	50	4
WM07600504B0025.006.050	0,5	0,25		0,5	6	50	4
WM07600504B0025.008.050	0,5	0,25		0,5	8	50	4
WM07600504B0025.010.050	0,5	0,25		0,5	10	50	4
WM07600604B0030.001.050	0,6	0,30		0,6	1	50	4
WM07600604B0030.002.050	0,6	0,30		0,6	2	50	4
WM07600604B0030.003.050	0,6	0,30		0,6	3	50	4
WM07600604B0030.004.050	0,6	0,30		0,6	4	50	4
WM07600604B0030.005.050	0,6	0,30		0,6	5	50	4
WM07600604B0030.006.050	0,6	0,30		0,6	6	50	4
WM07600604B0030.008.050	0,6	0,30		0,6	8	50	4
WM07600604B0030.010.050	0,6	0,30		0,6	10	50	4
WM07600604B0030.012.050	0,6	0,30		0,6	12	50	4
WM07600704B0035.002.050	0,7	0,35		0,7	2	50	4
WM07600704B0035.004.050	0,7	0,35		0,7	4	50	4
WM07600704B0035.008.050	0,7	0,35		0,7	8	50	4
WM07600704B0035.010.050	0,7	0,35		0,7	10	50	4
WM07600704B0035.012.050	0,7	0,35		0,7	12	50	4
WM07600804B0040.002.050	0,8	0,40		0,8	2	50	4
WM07600804B0040.004.050	0,8	0,40		0,8	4	50	4
WM07600804B0040.006.050	0,8	0,40		0,8	6	50	4
WM07600804B0040.008.050	0,8	0,40		0,8	8	50	4
WM07600804B0040.010.050	0,8	0,40		0,8	10	50	4
WM07600804B0040.012.050	0,8	0,40		0,8	12	50	4
WM07600904B0045.004.050	0,9	0,45		0,9	4	50	4

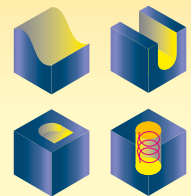

Продолжение таблицы см. на следующей странице



СЕРИЯ WM076 (сферический торец, обнижение рабочей части, продолжение размерного ряда)



Артикул	D, мм	R, мм	Допуск R, мм	l, мм	l ₁ , мм	L, мм	d, мм
WM07601004B0050.002.050	1,0	0,50	±0,015	1,0	2	50	4
WM07601004B0050.003.050	1,0	0,50		1,0	3	50	4
WM07601004B0050.004.050	1,0	0,50		1,0	4	50	4
WM07601006B0050.004.050	1,0	0,50		1,0	4	50	6
WM07601004B0050.005.050	1,0	0,50		1,0	5	50	4
WM07601004B0050.006.050	1,0	0,50		1,0	6	50	4
WM07601006B0050.006.050	1,0	0,50		1,0	6	50	6
WM07601004B0050.008.050	1,0	0,50		1,0	8	50	4
WM07601006B0050.008.050	1,0	0,50		1,0	8	50	6
WM07601004B0050.010.050	1,0	0,50		1,0	10	50	4
WM07601006B0050.010.050	1,0	0,50		1,0	10	50	6
WM07601004B0050.012.050	1,0	0,50		1,0	12	50	4
WM07601006B0050.012.050	1,0	0,50		1,0	12	50	6
WM07601004B0050.014.050	1,0	0,50		1,0	14	50	4
WM07601004B0050.016.050	1,0	0,50		1,0	16	50	4
WM07601004B0050.018.050	1,0	0,50		1,0	18	50	4
WM07601004B0050.020.050	1,0	0,50		1,0	20	50	4
WM07601004B0050.022.060	1,0	0,50		1,0	22	60	4
WM07601204B0060.004.050	1,2	0,60		1,2	4	50	4
WM07601204B0060.006.050	1,2	0,60		1,2	6	50	4
WM07601204B0060.008.050	1,2	0,60		1,2	8	50	4
WM07601204B0060.010.050	1,2	0,60		1,2	10	50	4
WM07601204B0060.012.050	1,2	0,60		1,2	12	50	4
WM07601204B0060.016.050	1,2	0,60		1,2	16	50	4
WM07601204B0060.020.050	1,2	0,60		1,2	20	50	4
WM07601204B0060.024.060	1,2	0,60		1,2	24	60	4
WM07601404B0070.006.050	1,4	0,70		1,4	6	50	4
WM07601404B0070.008.050	1,4	0,70		1,4	8	50	4
WM07601404B0070.012.050	1,4	0,70		1,4	12	50	4
WM07601404B0070.016.050	1,4	0,70		1,4	16	50	4
WM07601504B0075.003.050	1,5	0,75		1,5	3	50	4
WM07601504B0075.004.050	1,5	0,75		1,5	4	50	4
WM07601504B0075.006.050	1,5	0,75		1,5	6	50	4
WM07601506B0075.006.050	1,5	0,75		1,5	6	50	6
WM07601504B0075.008.050	1,5	0,75		1,5	8	50	4
WM07601506B0075.008.050	1,5	0,75		1,5	8	50	6
WM07601504B0075.010.050	1,5	0,75		1,5	10	50	4
WM07601506B0075.010.050	1,5	0,75		1,5	10	50	6
WM07601504B0075.012.050	1,5	0,75		1,5	12	50	4
WM07601506B0075.012.050	1,5	0,75		1,5	12	50	6
WM07601504B0075.014.050	1,5	0,75		1,5	14	50	4
WM07601504B0075.016.050	1,5	0,75		1,5	16	50	4
WM07601504B0075.018.050	1,5	0,75	1,5	18	50	4	
WM07601504B0075.020.050	1,5	0,75	1,5	20	50	4	
WM07601504B0075.022.060	1,5	0,75	1,5	22	60	4	
WM07601504B0075.025.060	1,5	0,75	1,5	25	60	4	
WM07601504B0075.030.075	1,5	0,75	1,5	30	75	4	
WM07601604B0080.006.050	1,6	0,80	1,6	6	50	4	
WM07601604B0080.008.050	1,6	0,80	1,6	8	50	4	
WM07601604B0080.012.050	1,6	0,80	1,6	12	50	4	
WM07601604B0080.016.050	1,6	0,80	1,6	16	50	4	
WM07601604B0080.020.050	1,6	0,80	1,6	20	50	4	

Z=2 λ=30°

AlTiCrN MG

U HRC 55

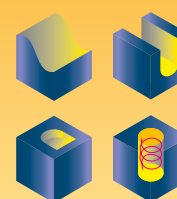

Продолжение таблицы см. на следующей странице



СЕРИЯ WM076 (сферический торец, обнижение рабочей части, продолжение размерного ряда)



Артикул	D, мм	R, мм	Допуск R, мм	l, мм	l ₁ , мм	L, мм	d, мм
WM07601804B0090.006.050	1,8	0,90	±0,015	1,8	6	50	4
WM07601804B0090.008.050	1,8	0,90		1,8	8	50	4
WM07601804B0090.012.050	1,8	0,90		1,8	12	50	4
WM07601804B0090.016.050	1,8	0,90		1,8	16	50	4
WM07601804B0090.020.050	1,8	0,90		1,8	20	50	4
WM07602004B0100.004.050	2,0	1,00		2,0	4	50	4
WM07602004B0100.006.050	2,0	1,00		2,0	6	50	4
WM07602004B0100.006.050	2,0	1,00		2,0	6	50	6
WM07602004B0100.008.050	2,0	1,00		2,0	8	50	4
WM07602004B0100.008.050	2,0	1,00		2,0	8	50	6
WM07602004B0100.010.050	2,0	1,00		2,0	10	50	4
WM07602004B0100.010.050	2,0	1,00		2,0	10	50	6
WM07602004B0100.012.050	2,0	1,00		2,0	12	50	4
WM07602004B0100.014.050	2,0	1,00		2,0	14	50	4
WM07602004B0100.016.050	2,0	1,00		2,0	16	50	4
WM07602004B0100.016.050	2,0	1,00		2,0	16	50	6
WM07602004B0100.018.050	2,0	1,00		2,0	18	50	4
WM07602004B0100.020.050	2,0	1,00		2,0	20	50	4
WM07602004B0100.022.060	2,0	1,00		2,0	22	60	4
WM07602004B0100.025.060	2,0	1,00		2,0	25	60	4
WM07602504B0125.006.050	2,5	1,25		2,5	6	50	6
WM07602504B0125.008.050	2,5	1,25		2,5	8	50	4
WM07602504B0125.010.050	2,5	1,25		2,5	10	50	4
WM07602504B0125.010.050	2,5	1,25		2,5	10	50	6
WM07602504B0125.016.050	2,5	1,25		2,5	16	50	4
WM07602504B0125.020.050	2,5	1,25		2,5	20	60	4
WM07602504B0125.025.060	2,5	1,25		2,5	25	60	4
WM07602504B0125.030.075	2,5	1,25		2,5	30	75	4
WM07603006B0150.006.050	3,0	1,50		3,0	6	50	6
WM07603006B0150.008.050	3,0	1,50		3,0	8	50	6
WM07603006B0150.012.050	3,0	1,50		3,0	12	50	6
WM07603006B0150.016.060	3,0	1,50		3,0	16	60	6
WM07603006B0150.020.060	3,0	1,50		3,0	20	60	6
WM07603006B0150.025.060	3,0	1,50	3,0	25	60	6	
WM07603006B0150.030.075	3,0	1,50	3,0	30	75	6	
WM07603006B0150.035.075	3,0	1,50	3,0	35	75	6	
WM07604006B0200.008.050	4,0	2,00	4,0	8	50	6	
WM07604006B0200.010.050	4,0	2,00	4,0	10	50	6	
WM07604006B0200.012.050	4,0	2,00	4,0	12	50	6	
WM07604006B0200.016.060	4,0	2,00	4,0	16	60	6	
WM07604006B0200.020.060	4,0	2,00	4,0	20	60	6	
WM07604006B0200.025.060	4,0	2,00	4,0	25	60	6	
WM07604006B0200.030.075	4,0	2,00	4,0	30	75	6	
WM07604006B0200.035.075	4,0	2,00	4,0	35	75	6	
WM07605006B0250.015.060	5,0	2,50	5,0	15	60	6	
WM07605006B0250.020.060	5,0	2,50	5,0	20	60	6	
WM07605006B0250.025.060	5,0	2,50	5,0	25	60	6	
WM07605006B0250.030.075	5,0	2,50	5,0	30	75	6	
WM07606006B0300.015.050	6,0	3,00	10,0	15	50	6	
WM07608008B0400.025.060	8,0	4,00	±0,020	12,0	25	60	8
WM07610010B0500.030.075	10,0	5,00	±0,020	16,0	30	75	10
WM07612012B0600.030.075	12,0	6,00	±0,020	18,0	30	75	12

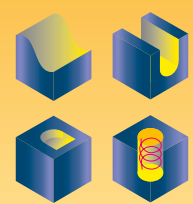
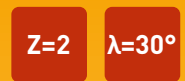

РЕЖИМЫ РЕЗАНИЯ ДЛЯ ФРЕЗ СЕРИИ WM076

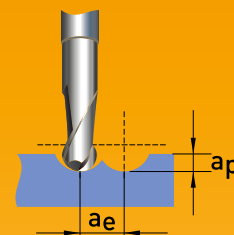

Материалы		Предварительно закаленные стали				Закаленные стали				Медь			
Твердость		35–45 HRC				40–55 HRC							
D, мм	l ₁	N, об./мин	V _f , мм/мин	a _p , мм	a _e , мм	N, об./мин	V _f , мм/мин	a _p , мм	a _e , мм	N, об./мин	V _f , мм/мин	a _p , мм	a _e , мм
0,3	1	48000	480	0,010	0,010	41000	370	0,009	0,010	54000	640	0,014	0,015
	2	43000	370	0,008	0,008	37000	270	0,008	0,008	49000	530	0,011	0,011
	3	38000	320	0,007	0,006	32000	240	0,006	0,006	43000	460	0,009	0,010
0,4	2	48000	590	0,018	0,024	37000	400	0,015	0,020	54000	790	0,022	0,036
	4	38000	400	0,009	0,012	30000	270	0,009	0,012	50000	640	0,012	0,018
	6	29000	260	0,005	0,006	26000	200	0,004	0,006	37000	360	0,006	0,010
	8	27000	170	0,003	0,003	23000	150	0,002	0,003	27000	200	0,003	0,006
0,5	2	42000	750	0,022	0,036	32000	500	0,018	0,036	57000	1250	0,028	0,054
	4	38000	580	0,017	0,024	31000	400	0,014	0,024	55000	1010	0,021	0,036
	6	28000	400	0,008	0,012	27000	330	0,005	0,012	36000	610	0,009	0,018
	10	28000	400	0,008	0,012	27000	330	0,005	0,012	36000	460	0,009	0,018
0,6	2	37000	770	0,027	0,144	37000	770	0,027	0,096	57000	1540	0,034	0,144
	4	35000	600	0,020	0,108	35000	600	0,020	0,072	54000	1130	0,026	0,108
	6	28000	460	0,016	0,072	28000	460	0,016	0,048	46000	960	0,019	0,072
	8	24000	400	0,009	0,054	24000	400	0,009	0,036	30000	570	0,010	0,054
	10	24000	330	0,006	0,036	24000	330	0,006	0,024	30000	490	0,007	0,036
	12	24000	330	0,006	0,036	24000	330	0,006	0,024	30000	490	0,007	0,036
0,7	4	33000	600	0,035	0,042	26500	410	0,029	0,096	54500	1500	0,045	0,063
	8	12215	420	0,020	0,048	22500	355	0,012	0,048	32000	800	0,019	0,072
	10	22500	380	0,014	0,042	21500	330	0,011	0,042	26500	540	0,017	0,063
	12	21500	380	0,012	0,032	21500	320	0,010	0,042	23000	420	0,017	0,063
0,8	4	31000	600	0,050	0,012	27000	440	0,041	0,120	55000	1860	0,063	0,018
	8	21000	430	0,021	0,060	22000	390	0,018	0,060	34000	1040	0,027	0,090
	12	19000	430	0,018	0,040	20000	350	0,016	0,060	16000	350	0,027	0,090
0,9	4	32000	685	0,054	0,130	24500	460	0,043	0,180	50500	1900	0,067	0,190
1,0	4	32000	770	0,057	0,240	22000	480	0,045	0,240	46000	2000	0,071	0,360
	6	26000	760	0,055	0,120	17600	480	0,009	0,120	39000	1500	0,071	0,180
	8	26000	760	0,034	0,120	17600	480	0,027	0,120	39000	1500	0,043	0,180
	12	17600	530	0,024	0,060	16500	420	0,018	0,060	18700	660	0,027	0,090
	16	15400	440	0,018	0,060	14300	360	0,014	0,060	18700	640	0,022	0,090
	22	14300	360	0,013	0,036	13200	300	0,009	0,036	18700	540	0,017	0,054

1. Необходимо стремиться к наибольшей жесткости системы СПИД.
2. В случае изменения скорости резания V_c (количества оборотов/мин, N), скорость подачи (V_f) необходимо пропорционально изменить.
3. При увеличении вылета инструмента требуется уменьшить обороты и скорость подачи.
4. Режимы резания носят исключительно рекомендательный характер. Окончательные значения режимов резания уточняются на стадии отработки конкретной технологической операции в производственных условиях.

РЕЖИМЫ РЕЗАНИЯ ДЛЯ ФРЕЗ СЕРИИ WM076

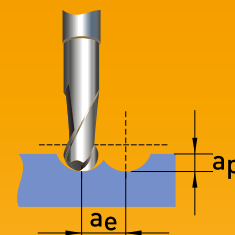

Материалы		Предварительно закаленные стали				Закаленные стали				Медь			
Твердость		35-45 HRC				40-55 HRC							
D, мм	l1	N, об./мин	Vf, мм/мин	ap, мм	ae, мм	N, об./мин	Vf, мм/мин	ap, мм	ae, мм	N, об./мин	Vf, мм/мин	ap, мм	ae, мм
1,2	6	26000	770	0,068	0,240	18200	480	0,054	0,240	38000	2000	0,085	0,360
	10	16400	530	0,027	0,120	15100	420	0,022	0,120	24000	1080	0,036	0,180
	12	15300	530	0,027	0,120	14100	420	0,022	0,120	24000	1080	0,036	0,180
	16	13100	460	0,019	0,096	11900	380	0,016	0,096	15400	580	0,024	0,144
	20	12100	380	0,013	0,060	11000	320	0,009	0,096	15400	580	0,017	0,090
	24	11100	320	0,009	0,040	9800	290	0,070	0,040	15400	580	0,010	0,060
1,4	6	17600	680	0,076	0,180	13600	440	0,063	0,180	28000	1470	0,099	0,270
	8	17600	680	0,079	0,180	13600	440	0,063	0,180	28000	1470	0,099	0,270
	12	13800	530	0,033	0,180	13600	420	0,027	0,180	19800	1080	0,042	0,270
	16	13100	480	0,027	0,120	11900	390	0,021	0,120	13200	620	0,033	0,180
1,5	4	21000	1060	0,137	0,216	14800	660	0,110	0,216	30000	2200	0,171	0,324
	8	16300	700	0,084	0,180	12100	450	0,069	0,180	26000	1500	0,106	0,270
	12	16300	700	0,084	0,180	12100	450	0,069	0,180	26000	1500	0,106	0,270
	16	12400	480	0,027	0,120	11600	390	0,022	0,120	12100	620	0,036	0,180
	20	12400	480	0,016	0,060	11600	390	0,012	0,060	12100	620	0,019	0,090
	25	12400	440	0,016	0,060	11000	390	0,012	0,060	11000	500	0,019	0,090
	30	10900	400	0,016	0,060	11000	390	0,012	0,060	10700	450	0,019	0,090
1,6	8	18900	940	0,126	0,216	13800	580	0,102	0,216	26000	1970	0,157	0,324
	12	15100	700	0,090	0,120	11500	440	0,072	0,120	25000	1490	0,112	0,180
	16	12300	530	0,036	0,096	11400	440	0,030	0,096	17600	110	0,046	0,144
	20	11500	480	0,030	0,060	10900	400	0,024	0,060	11000	630	0,036	0,090
1,8	6	18400	1200	0,185	0,320	18400	738	0,150	0,320	32000	2600	0,230	0,021
	12	13800	700	0,094	0,180	10300	440	0,077	0,180	21000	1480	0,120	0,270
	16	10800	530	0,039	0,120	9900	420	0,031	0,120	15400	1080	0,048	0,180
	20	10200	480	0,031	0,060	9700	400	0,025	0,060	10500	630	0,039	0,090
2,0	6	18500	1260	0,185	0,360	13200	960	0,150	0,360	22000	2140	0,232	0,540
	10	18500	1120	0,147	0,240	13200	870	0,120	0,240	22000	1920	0,185	0,360
	12	16000	990	0,133	0,240	11700	780	0,107	0,240	18700	1470	0,166	0,360
	16	16000	990	0,118	0,240	11700	780	0,090	0,240	18700	1470	0,148	0,360
	18	14700	580	0,074	0,120	11600	580	0,061	0,120	14300	1070	0,093	0,180
	20	14700	580	0,074	0,120	11600	580	0,061	0,120	14300	1070	0,093	0,180
	25	10600	450	0,058	0,120	10200	450	0,045	0,120	9500	630	0,074	0,180

1. Необходимо стремиться к наибольшей жесткости системы СПИД.
2. В случае изменения скорости резания V_c (количества оборотов/мин, N), скорость подачи (V_f) необходимо пропорционально изменить.
3. При увеличении вылета инструмента требуется уменьшить обороты и скорость подачи.
4. Режимы резания носят исключительно рекомендательный характер. Окончательные значения режимов резания уточняются на стадии отработки конкретной технологической операции в производственных условиях.

РЕЖИМЫ РЕЗАНИЯ ДЛЯ ФРЕЗ СЕРИИ WM076

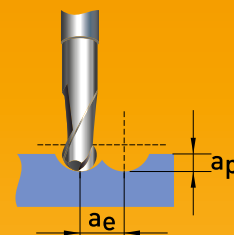

Материалы		Предварительно закаленные стали				Закаленные стали				Медь			
Твердость		35-45 HRC				40-55 HRC							
D, мм	l ₁	N, об./мин	V _f , мм/мин	a _p , мм	a _e , мм	N, об./мин	V _f , мм/мин	a _p , мм	a _e , мм	N, об./мин	V _f , мм/мин	a _p , мм	a _e , мм
2,5	8	14500	1400	0,185	0,240	9700	1080	0,150	0,240	18400	2400	0,232	0,360
	10	14500	1400	0,185	0,240	9700	1080	0,150	0,240	18400	2400	0,232	0,360
	16	13500	1230	0,166	0,240	8400	980	0,135	0,240	16100	1810	0,208	0,360
	20	10200	950	0,093	0,120	8400	980	0,074	0,120	11500	1330	0,116	0,180
	25	8400	540	0,074	0,120	8400	560	0,061	0,120	6900	770	0,093	0,180
	30	8400	540	0,033	0,060	8400	560	0,026	0,060	6900	770	0,040	0,090
3,0	8	12900	1680	0,222	0,360	9200	1300	0,180	0,360	15000	2890	0,278	0,540
	12	12900	1510	0,222	0,360	9200	1170	0,180	0,360	15000	2600	0,278	0,540
	16	11300	1330	0,166	0,360	8100	1040	0,135	0,360	12700	1970	0,029	0,504
	20	11300	1330	0,166	0,360	8100	1040	0,135	0,360	12700	1970	0,029	0,504
	25	8800	1040	0,111	0,180	8100	1040	0,090	0,180	10100	1450	0,139	0,270
	30	8800	780	0,111	0,180	8100	780	0,090	0,180	10100	1450	0,139	0,270
	35	7900	62	0,055	0,180	7500	650	0,045	0,180	6600	840	0,073	0,270
4,0	8	9700	1560	0,297	0,600	6800	1210	0,241	0,600	11500	2710	0,370	0,900
	12	9700	1560	0,297	0,600	6800	1210	0,241	0,600	11500	2710	0,390	0,900
	16	9700	1560	0,297	0,600	6800	1210	0,241	0,600	11500	2710	0,390	0,900
	20	9700	1560	0,297	0,600	6800	1210	0,241	0,600	11500	2710	0,390	0,900
	25	8400	1250	0,223	0,360	6000	980	0,180	0,360	10300	1850	0,279	0,540
	30	8400	1250	0,223	0,360	6000	980	0,180	0,361	10300	1850	0,279	0,540
	35	6600	950	0,148	0,360	6000	700	0,120	0,360	7500	1360	0,185	0,540
5,0	15	7800	1350	0,324	0,800	5600	1050	0,252	0,800	9600	2590	0,406	0,900
	20	7800	1240	0,324	0,600	5600	950	0,252	0,600	9600	2100	0,406	0,900
	25	7800	1240	0,324	0,600	5600	950	0,252	0,600	9600	2100	0,406	0,900
	30	7800	760	0,243	0,600	4800	600	0,197	0,600	8200	1320	0,305	0,900
6,0	15	7400	1670	0,443	1,200	5200	1300	0,360	1,200	8000	2530	0,555	1,800
8,0	25	7200	1200	0,500	1,000	5200	920	0,350	1,000	9000	2400	0,600	1,500
10,0	30	6800	720	0,230	0,600	4600	570	0,190	0,570	7800	1300	0,300	0,900
12,0	30	6350	684	0,210	0,570	4370	541,5	0,181	0,550	7410	1235	0,285	0,855

1. Необходимо стремиться к наибольшей жесткости системы СПИД.
2. В случае изменения скорости резания V_c (количества оборотов/мин, N), скорость подачи (V_f) необходимо пропорционально изменить.
3. При увеличении вылета инструмента требуется уменьшить обороты и скорость подачи.
4. Режимы резания носят исключительно рекомендательный характер. Окончательные значения режимов резания уточняются на стадии отработки конкретной технологической операции в производственных условиях.

СЕРИЯ WM059

(сферический торец, коническое обнижение рабочей части)

Фрезы твердосплавные концевые с коническим обнижением рабочей части для общей универсальной обработки материалов 20–55 HRC: углеродистых, конструкционных, легированных и термоупрочненных сталей, нержавеющей сталей, чугунов.

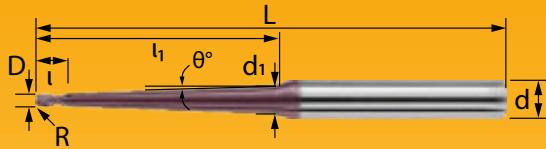

- Исполнение с высокотехнологичным покрытием AlTiCrN увеличивает износостойкость и снижает коэффициент трения.
- Различный угол конуса рабочей части делает ее пригодной для различных применений.
- Применяются для высокопроизводительного профильного фрезерования
- Высокая прочность конической шейки позволяет обрабатывать глубокие канавки без поломок фрезы.

Артикул	D, мм	R, мм	d1, мм	Допуск R, мм	θ°	l, мм	l1, мм	L, мм	d, мм
WM05902006BA015N	1	0,5	2,10	±0,015	1,5°	2	23	60	6
WM05902006BA050N	1	0,5	4,67		5,0°	2	23	60	6
WM05902006BA030L	1	0,5	5,19		3,0°	2	42	75	6
WM05904006BA005L	2	1,0	2,54		0,5°	4	35	75	6
WM05904006BA010L	2	1,0	3,08		1,0°	4	35	75	6
WM05904006BA015N	2	1,0	3,00		1,5°	4	23	60	6
WM05904006BA015L	2	1,0	3,62		1,5°	4	35	75	6
WM05904006BA050N	2	1,0	5,32		5,0°	4	23	60	6
WM05904006BA030L	2	1,0	5,88		3,0°	4	41	75	6
WM05906006BA015L	3	1,5	5,40		1,5°	6	52	100	6
WM05906006BA030N	3	1,5	5,73		3,0°	6	32	75	6
WM05908006BA015L	4	2,0	6,00		1,5°	8	46	100	6
WM05908006BA030N	4	2,0	6,00		3,0°	8	27	75	6

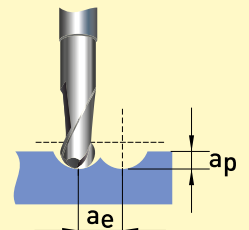
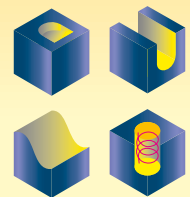

РЕЖИМЫ РЕЗАНИЯ ДЛЯ ФРЕЗ СЕРИИ WM059

Материалы	Легированные стали/Инструментальные стали						Закаленные стали		Нержавеющие стали		Чугуны	
	HRC < 20		20–30 HRC		30–40 HRC		45–55 HRC		—		—	
Vc	94 м/мин		71 м/мин		34 м/мин		38 м/мин		71 м/мин		94 м/мин	
D, мм	N, об./мин	Vf, мм/мин	N, об./мин	Vf, мм/мин	N, об./мин	Vf, мм/мин	N, об./мин	Vf, мм/мин	N, об./мин	Vf, мм/мин	N, об./мин	Vf, мм/мин
1,0	26676	700	21060	470	15210	280	10660	140	21060	555	29718	780
2,0	14976	875	11232	560	8190	335	5980	175	11232	655	14976	875
3,0	9828	860	7488	560	4914	300	3926	170	7488	655	9828	860

$a_p = 0,05D$
 $pf = 0,1D$

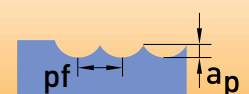

1. Необходимо стремиться к наибольшей жесткости системы СПИД.
2. В случае изменения скорости резания Vc (количества оборотов/мин, N), скорость подачи (Vf) необходимо пропорционально изменить.
3. При увеличении вылета инструмента требуется уменьшить обороты и скорость подачи.
4. Режимы резания носят исключительно рекомендательный характер. Окончательные значения режимов резания уточняются на стадии отработки конкретной технологической операции в производственных условиях.

СЕРИЯ WM058 (сферический торец, коническая режущая часть)

Фрезы твердосплавные концевые с конической рабочей частью для общей универсальной обработки материалов 20–55 HRC: углеродистых, конструкционных, легированных и термоупрочненных сталей, нержавеющей сталей, чугунов.

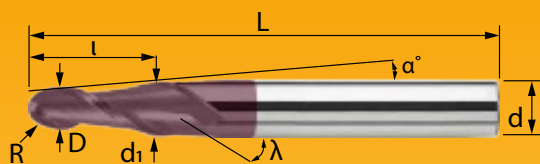

- Исполнение с высокотехнологичным покрытием AlTiCrN увеличивает износостойкость и снижает коэффициент трения.
- Высокая прочность конической режущей части позволяет формировать глубокие канавки без поломок фрезы.
- Конструкция для высокопроизводительной 3D-обработки.

Артикул	D, мм	R, мм	d ₁ , мм	Допуск R, мм	α°	l, мм	L, мм	d, мм
WM05802004BT010N	2,0	1,00	2,24	±0,015	1°	8	50	4,0
WM05802004BT030N	2,0	1,00	2,74		3°	8	50	4,0
WM05802004BT050N	2,0	1,00	3,23		5°	8	50	4,0
WM05802504BT010N	2,5	1,25	2,81		1°	10	50	4,0
WM05802504BT030N	2,5	1,25	3,42		3°	10	50	4,0
WM05802506BT050N	2,5	1,25	4,04		5°	10	50	6,0
WM05803004BT010N	3,0	1,50	3,37		1°	12	50	4,0
WM05803006BT030N	3,0	1,50	4,10		3°	12	50	6,0
WM05803006BT050N	3,0	1,50	4,85		5°	12	50	6,0
WM05804006BT010N	4,0	2,00	4,49		1°	16	60	6,0
WM05804006BT030N	4,0	2,00	5,47		3°	16	60	6,0
WM05804008BT050N	4,0	2,00	6,46		5°	16	60	8,0
WM05806008BT010N	6,0	3,00	6,73		1°	24	75	8,0
WM05806010BT030N	6,0	3,00	8,20		3°	24	75	10,0
WM05806010BT050N	6,0	3,00	9,67		5°	24	75	10,0

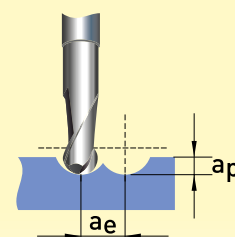
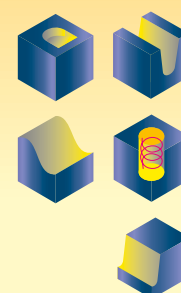

РЕЖИМЫ РЕЗАНИЯ ДЛЯ ФРЕЗ СЕРИИ WM058

Материалы	Легированные стали/Инструментальные стали						Закаленные стали		Нержавеющие стали		Чугуны	
	HRC < 20		20–30 HRC		30–40 HRC		45–55 HRC		—		—	
V _c	94 м/мин		71 м/мин		34 м/мин		38 м/мин		71 м/мин		94 м/мин	
D, мм	N, об./мин	V _f , мм/мин	N, об./мин	V _f , мм/мин	N, об./мин	V _f , мм/мин	N, об./мин	V _f , мм/мин	N, об./мин	V _f , мм/мин	N, об./мин	V _f , мм/мин
1,0	26676	700	2106	470	1521	280	1066	140	2106	555	29718	780
2,0	14976	875	11232	560	819	335	598	175	11232	655	14976	875
3,0	9828	860	7488	560	4914	300	3926	170	7488	655	9828	860

$$a_p = 0,05D$$

$$p_f = 0,1D$$

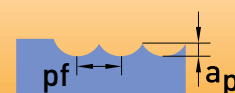

1. Необходимо стремиться к наибольшей жесткости системы СПИД.
2. В случае изменения скорости резания V_c (количества оборотов/мин, N), скорость подачи (V_f) необходимо пропорционально изменить.
3. При увеличении вылета инструмента требуется уменьшить обороты и скорость подачи.
4. Режимы резания носят исключительно рекомендательный характер. Окончательные значения режимов резания уточняются на стадии отработки конкретной технологической операции в производственных условиях.

СЕРИЯ WM057 (сферический торец)

Фрезы двузубые из микроструктурированного твердого сплава для общей универсальной обработки материалов твердостью 20–55 HRC: сталей, легированных сталей, жаропрочных сталей, нержавеющей сталей, серых чугунов. Возможна обработка материалов группы S.

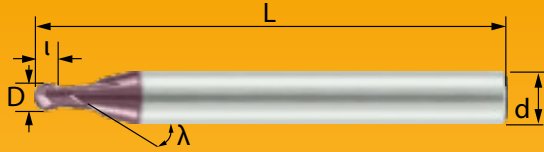

- Исполнение с высокотехнологичным покрытием AlTiCrN увеличивает износостойкость и снижает коэффициент трения.
- Длина режущей части примерно $1 \times D$.
- Угловой радиус защищает режущую кромку от выкрашивания и позволяет осуществлять профильное фрезерование.

- Короткая режущая часть с высокой жесткостью позволяет фрезеровать с высокой подачей.
- Для штампов, пресс-форм, механических и электронных деталей из стали.
- Хорошо подходит для отделки поверхности.

Артикул	D, мм	R, мм	Допуск R, мм	l, мм	L, мм	d, мм
WM05700204B0010N	0,2	0,10	±0,015	0,2	50	4
WM05700304B0015N	0,3	0,15		0,3	50	4
WM05700404B0020N	0,4	0,20		0,4	50	4
WM05700504B0025N	0,5	0,25		0,5	50	4
WM05700604B0030N	0,6	0,30		0,6	50	4
WM05700704B0035N	0,7	0,35		0,7	50	4
WM05700804B0040N	0,8	0,40		0,8	50	4
WM05700904B0045N	0,9	0,45		0,9	50	4
WM05701004B0050N	1,0	0,50		1,0	50	4
WM05701204B0060N	1,2	0,60		1,2	50	4
WM05701404B0070N	1,4	0,70		1,4	50	4
WM05701504B0075N	1,5	0,75		1,5	50	4
WM05701604B0080N	1,6	0,80		1,6	50	4
WM05701804B0090N	1,8	0,90		1,8	50	4
WM05702004B0100N	2,0	1,00		2,0	50	4
WM05702504B0125N	2,5	1,25		2,5	50	4
WM05703006B0150N	3,0	1,50		3,0	50	6
WM05704006B0200N	4,0	2,00		4,0	50	6
WM05705006B0250N	5,0	2,50		5,0	50	6
WM05706006B0300N	6,0	3,00		9,0	50	6

Z=2 λ=30°

AlTiCrN MG

U HRC 55

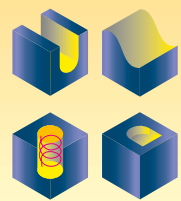

РЕЖИМЫ РЕЗАНИЯ ДЛЯ ФРЕЗ СЕРИИ WM057

Материал	Применение	a _e , мм	a _p , мм	V _c , м/мин	f _z , мм/з					
					1 мм	2 мм	3 мм	4 мм	5 мм	6 мм
Углеродистые стали	Обработка пазов	1×d	≤0,5×d	50–90	0,007	0,013	0,018	0,024	0,030	0,036
	Обработка уступов	≤0,3×d	≤0,3×d	55–100	0,007	0,013	0,018	0,024	0,030	0,036
	Контурная обработка	≤0,3×d	≤0,1×d	80–135	0,007	0,013	0,018	0,024	0,030	0,036
Легированные стали / Инструментальные стали	Обработка пазов	1×d	≤0,5×d	40–70	0,006	0,012	0,017	0,022	0,028	0,033
	Обработка уступов	≤0,3×d	≤0,3×d	40–80	0,006	0,012	0,017	0,022	0,028	0,033
	Контурная обработка	≤0,3×d	≤0,1×d	55–100	0,006	0,012	0,017	0,022	0,028	0,033
Нержавеющие стали	Обработка пазов	1×d	≤0,5×d	30–40	0,006	0,011	0,015	0,020	0,025	0,030
	Обработка уступов	≤0,3×d	≤0,3×d	40–60	0,006	0,011	0,015	0,020	0,025	0,030
	Контурная обработка	≤0,3×d	≤0,1×d	50–70	0,006	0,011	0,015	0,020	0,025	0,030
Закаленные стали / Жаропрочные сплавы	Обработка пазов	1×d	≤0,5×d	20–40	0,005	0,010	0,014	0,018	0,023	0,027
	Обработка уступов	≤0,3×d	≤0,3×d	30–55	0,005	0,010	0,014	0,018	0,023	0,027
	Контурная обработка	≤0,3×d	≤0,1×d	40–70	0,005	0,010	0,014	0,018	0,023	0,027

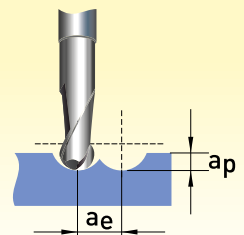

1. Необходимо стремиться к наибольшей жесткости системы СПИД.
2. В случае изменения скорости резания V_c (количества оборотов/мин, N), скорость подачи (V_f) необходимо пропорционально изменить.
3. При увеличении вылета инструмента требуется уменьшить обороты и скорость подачи.
4. Режимы резания носят исключительно рекомендательный характер. Окончательные значения режимов резания уточняются на стадии отработки конкретной технологической операции в производственных условиях.

СЕРИИ WM054/WM056 (сферический торец)

Фрезы четырехзубые из микрзернистого твердого сплава для общей универсальной обработки материалов твердостью 20–55 HRC: сталей, легированных сталей, нержавеющей сталей, жаропрочных сталей, серых чугунов.



рис. 1 WM054~



рис. 2 WM056~

- Обеспечивает превосходную поверхность благодаря лучшему шлифованию поверхности.
- Новая геометрия инструмента повышает износостойкость, а сила резания снижается.
- Высокотехнологичное износостойкое покрытие AlTiCrN снижает трение и увеличивает стойкость фрез.
- Высокопозитивная геометрия режущих кромок придает высокие режущие свойства и обеспечивает превосходную точность.

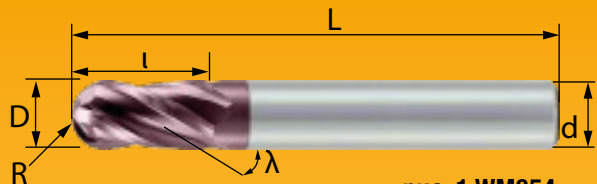
Артикулы		D, мм	R, мм	Допуск R, мм	l, мм	L, мм	d, мм
рис. 1, WM054~	рис. 2, WM056~						
WM054B02004R0100N	—	2	1,0	±0,015	4	50	4
WM054B03004R0150N	—	3	1,5		6	50	4
WM054B04004R0200N	—	4	2,0		8	50	4
—	WM054B04004R0200L	4	2,0		8	75	4
—	WM054B04004R0200XL	4	2,0		8	100	4
WM054B04006R0200N	—	4	2,0		8	50	6
—	WM054B04006R0200L	4	2,0		8	75	6
—	WM054B04006R0200XL	4	2,0		8	100	6
WM054B05006R0250N	—	5	2,5		10	50	6
WM054B06006R0300N	—	6	3,0		12	50	6
—	WM054B06006R0300L	6	3,0	12	75	6	
—	WM054B06006R0300XL	6	3,0	12	100	6	
WM054B08008R0400N	—	8	4,0	±0,020	16	60	8
—	WM054B08008R0400L	8	4,0		16	75	8
—	WM054B08008R0400XL	8	4,0		16	100	8
—	WM054B08008R0400XXL	8	4,0		16	150	8
WM054B10010R0500N	—	10	5,0	±0,020	20	75	10
—	WM054B10010R0500L	10	5,0		20	100	10
—	WM054B10010R0500XL	10	5,0		20	150	10
WM054B12012R0600N	—	12	6,0	±0,020	24	75	12
—	WM054B12012R0600L	12	6,0		24	100	12
—	WM054B12012R0600XL	12	6,0		24	150	12
WM054B16016R0800N	—	16	8,0	±0,020	32	100	16
—	WM054B16016R0800L	16	8,0		32	150	16
WM054B20020R1000N	—	20	10,0	±0,020	40	100	20

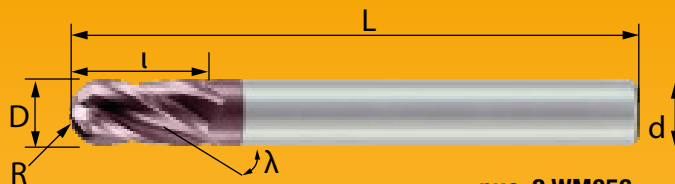
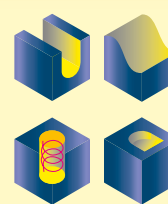

РЕЖИМЫ РЕЗАНИЯ ДЛЯ ФРЕЗ СЕРИИ WM054

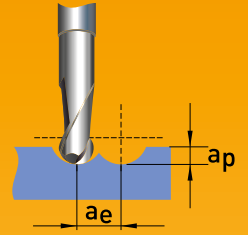

Материалы	Углеродистые стали / Легированные стали				Легированные стали / Инструментальные стали				Предварительно закаленные стали				Закаленные стали				Нержавеющие стали				Чугуны			
	Твердость 180–250 НВ				25–35 HRC				35–45 HRC				40–55 HRC											
D, мм	V _c 120 м/мин				95 м/мин				79 м/мин				48 м/мин				79 м/мин				120 м/мин			
	N, об./мин	V _f , мм/мин	a _p , мм	a _e , мм	N, об./мин	V _f , мм/мин	a _p , мм	a _e , мм	N, об./мин	V _f , мм/мин	a _p , мм	a _e , мм	N, об./мин	V _f , мм/мин	a _p , мм	a _e , мм	N, об./мин	V _f , мм/мин	a _p , мм	a _e , мм	N, об./мин	V _f , мм/мин	a _p , мм	a _e , мм
1	37470	936	0,14	0,2	29660	740	0,14	0,2	24660	616	0,14	0,2	14990	374	0,14	0,2	24660	616	0,14	0,2	37470	936	0,14	0,2
2	18730	1120	0,28	0,4	14830	890	0,28	0,4	12330	740	0,28	0,4	7490	450	0,28	0,4	12330	740	0,28	0,4	18730	1120	0,28	0,4
3	12490	936	0,42	0,6	9890	740	0,42	0,6	8220	616	0,42	0,6	4995	374	0,42	0,6	8220	616	0,42	0,6	12490	936	0,42	0,6
4	9366	750	0,56	0,8	7415	593	0,56	0,8	6170	494	0,56	0,8	3750	300	0,56	0,8	6170	494	0,56	0,8	9366	750	0,56	0,8
5	7490	636	0,70	1,0	5930	504	0,70	1,0	4930	420	0,70	1,0	3000	255	0,70	1,0	4930	420	0,70	1,0	7490	636	0,70	1,0
6	6244	560	0,84	1,2	4940	444	0,84	1,2	4110	370	0,84	1,2	2500	225	0,84	1,2	4110	370	0,84	1,2	6244	560	0,84	1,2

РЕЖИМЫ РЕЗАНИЯ ДЛЯ ФРЕЗ СЕРИИ WM056

Материалы	Углеродистые стали / Легированные стали				Легированные стали / Инструментальные стали				Предварительно закаленные стали				Закаленные стали				Нержавеющие стали				Чугуны			
	Твердость 180–250 НВ				25–35 HRC				35–45 HRC				40–55 HRC											
D, мм	V _c 120 м/мин				95 м/мин				79 м/мин				48 м/мин				79 м/мин				120 м/мин			
	N, об./мин	V _f , мм/мин	a _p , мм	a _e , мм	N, об./мин	V _f , мм/мин	a _p , мм	a _e , мм	N, об./мин	V _f , мм/мин	a _p , мм	a _e , мм	N, об./мин	V _f , мм/мин	a _p , мм	a _e , мм	N, об./мин	V _f , мм/мин	a _p , мм	a _e , мм	N, об./мин	V _f , мм/мин	a _p , мм	a _e , мм
1	31850	796	0,14	0,2	25210	629	0,14	0,2	20960	524	0,14	0,2	12740	318	0,14	0,2	20960	524	0,14	0,2	31850	796	0,14	0,2
2	15920	952	0,28	0,4	12606	757	0,28	0,4	10480	629	0,28	0,4	6370	383	0,28	0,4	10480	629	0,28	0,4	15920	952	0,28	0,4
3	10620	796	0,42	0,6	8400	629	0,42	0,6	6990	524	0,42	0,6	4246	318	0,42	0,6	6990	524	0,42	0,6	10620	796	0,42	0,6
4	7960	638	0,56	0,8	6300	504	0,56	0,8	5245	420	0,56	0,8	3188	255	0,56	0,8	5245	420	0,56	0,8	7960	638	0,56	0,8
5	6370	540	0,70	1,0	5040	428	0,70	1,0	4190	357	0,70	1,0	2550	217	0,70	1,0	4190	357	0,70	1,0	6370	540	0,70	1,0
6	5308	476	0,84	1,2	4200	377	0,84	1,2	3495	315	0,84	1,2	2125	191	0,84	1,2	3495	315	0,84	1,2	5308	476	0,84	1,2

1. Необходимо стремиться к наибольшей жесткости системы СПИД.
2. В случае изменения скорости резания V_c (количества оборотов/мин, N), скорость подачи (V_f) необходимо пропорционально изменить.
3. При увеличении вылета инструмента требуется уменьшить обороты и скорость подачи.
4. Режимы резания носят исключительно рекомендательный характер. Окончательные значения режимов резания уточняются на стадии отработки конкретной технологической операции в производственных условиях.

8.3. ФРЕЗЫ СПЕЦИАЛЬНОЙ КОНСТРУКЦИИ

СЕРИИ WM071/WM072/WM073

(многофункциональные фрезы с углом при вершине 60/90/120 градусов)

Фрезы твердосплавные концевые многофункциональные для общей универсальной обработки материалов 25–40 HRC: углеродистых, конструкционных, легированных и термоупрочненных сталей, нержавеющей сталей, чугунов.

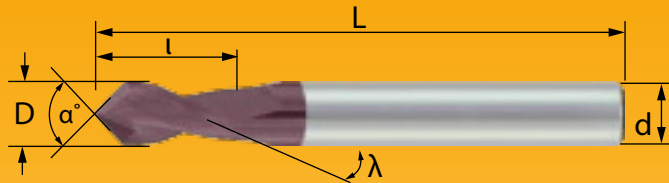

- Исполнение с высокотехнологичным покрытием AlTiCrN увеличивает износостойкость и снижает коэффициент трения.
- Конструкция фрез позволяет осуществлять одной фрезой несколько операций:
 - сверление;
 - образование фаски;
 - обработку кромки;
 - зенкование;
 - центрование.

Артикулы			D, мм	Точность исполнения рабочей части, мм	l, мм	L, мм	d, мм
$\alpha^\circ = 60^\circ$, WM071~	$\alpha^\circ = 90^\circ$, WM072~	$\alpha^\circ = 120^\circ$, WM073~					
~03006A0600N	~03006A0900N	~03006A1200N	3	0 ~ -0,02	6	50	6
~04006A0600N	~04006A0900N	~04006A1200N	4		8	50	6
~05006A0600N	~05006A0900N	~05006A1200N	5		10	50	6
~06006A0600N	~06006A0900N	~06006A1200N	6		12	50	6
~08008A0600N	~08008A0900N	~08008A1200N	8	0 ~ -0,03	16	60	8
~10010A0600N	~10010A0900N	~10010A1200N	10		20	75	10
~12012A0600N	~12012A0900N	~12012A1200N	12		24	75	12

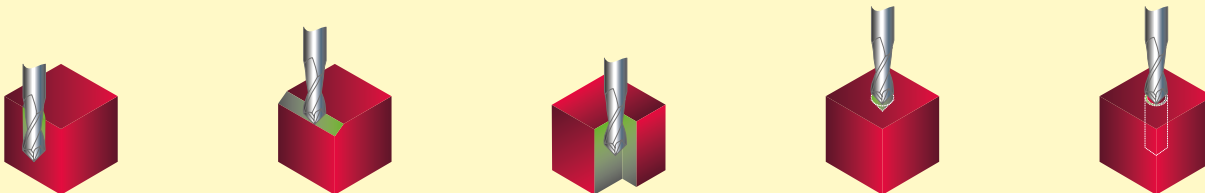

РЕЖИМЫ РЕЗАНИЯ ДЛЯ ФРЕЗ СЕРИЙ WM071/WM072/WM073

Материалы	Автоматные стали			Легированные/Инструментальные стали/ Предварительно закаленные стали			Нержавеющие стали			Алюминиевые сплавы		
	HRC < 20			HRC < 30–40			-			-		
V_c	60 м/мин			50 м/мин			40 м/мин			100 м/мин		
D, мм	N, об/мин	V_f , мм/мин		N, об/мин	V_f , мм/мин		N, об/мин	V_f , мм/мин		N, об/мин	V_f , мм/мин	
		Вертикально	Горизонтально		Вертикально	Горизонтально		Вертикально	Горизонтально		Вертикально	Горизонтально
3	6400	25	50	5300	20	40	4200	20	40	10600	40	80
4	4800	25	55	4000	20	45	3200	20	45	8000	40	85
6	3200	25	60	2650	20	50	2100	20	50	5300	40	90
8	2400	25	65	2000	20	55	1600	20	55	4000	40	110
10	1900	25	70	1600	20	60	1300	20	60	3200	40	110
12	1600	25	70	1350	20	60	1050	20	60	2700	40	120

1. Необходимо стремиться к наибольшей жесткости системы СПИД.
2. В случае изменения скорости резания V_c (количества оборотов/мин, N), скорость подачи (V_f) необходимо пропорционально изменить.
3. При увеличении вылета инструмента требуется уменьшить обороты и скорость подачи.
4. Режимы резания носят исключительно рекомендательный характер. Окончательные значения режимов резания уточняются на стадии отработки конкретной технологической операции в производственных условиях.

СЕРИИ WM069/WM070 (фасочные фрезы с углом при вершине 60/90 градусов)

Фрезы твердосплавные концевые многофункциональные для общей универсальной обработки материалов 25–55 HRC: углеродистых, конструкционных, легированных и термоупрочненных сталей, нержавеющей сталей, чугунов.

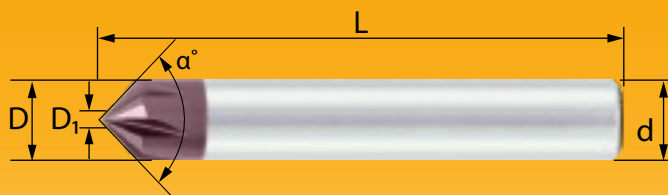

- Исполнение с высокотехнологичным покрытием AlTiCrN увеличивает износостойкость и снижает коэффициент трения.

Артикулы		D, мм	D ₁ , мм	L, мм	d, мм	z
α° = 60°, WM069~	α° = 90°, WM070~					
WM070A04004A0600N	WM070A04004A0900N	4	0,5	50	4	4
WM070A06006A0600N	WM070A06006A0900N	6	1,0	60	6	4
WM070A08008A0600N	WM070A08008A0900N	8	1,5	60	8	5
WM070A10010A0600N	WM070A10010A0900N	10	1,5	75	10	6
WM070A12012A0600N	WM070A12012A0900N	12	2,0	75	12	6

Z=4 Z=5

Z=6 HRC 55

AlTiCrN MG



РЕЖИМЫ РЕЗАНИЯ ДЛЯ ФРЕЗ СЕРИЙ WM069/WM070

Материалы	Углеродистые/Легированные стали/Чугуны					Легированные/Инструментальные стали/Предварительно закаленные стали					Нержавеющие стали					Закаленные стали				
Твердость	HRC < 30					30–40 HRC					-					40–55 HRC				
V _c	80–230 м/мин					60–180 м/мин					45–140 м/мин					25–30 м/мин				
D, мм	f _z (мм/з)	α = 60°		α = 90°		f _z (мм/з)	α = 60°		α = 90°		f _z (мм/з)	α = 60°		α = 90°		f _z (мм/з)	α = 60°		α = 90°	
		a _p , мм	a _e , мм	a _p , мм	a _e , мм		a _p , мм	a _e , мм	a _p , мм	a _e , мм		a _p , мм	a _e , мм	a _p , мм	a _e , мм		a _p , мм	a _e , мм	a _p , мм	a _e , мм
4	0,04	0,30	0,20	0,20	0,20	0,04	0,30	0,20	0,20	0,20	0,04	0,30	0,20	0,20	0,20	0,04	0,30	0,20	0,20	0,20
6	0,04	0,45	0,30	0,30	0,30	0,04	0,45	0,30	0,30	0,30	0,04	0,45	0,30	0,30	0,30	0,04	0,45	0,30	0,30	0,30
8	0,05	0,60	0,40	0,40	0,40	0,05	0,60	0,40	0,40	0,40	0,05	0,60	0,40	0,40	0,40	0,05	0,60	0,40	0,40	0,40
10	0,06	0,75	0,50	0,50	0,50	0,06	0,75	0,50	0,50	0,50	0,06	0,75	0,50	0,50	0,50	0,06	0,75	0,50	0,50	0,50
12	0,07	0,90	0,60	0,60	0,60	0,07	0,90	0,60	0,60	0,60	0,07	0,90	0,60	0,60	0,60	0,07	0,90	0,60	0,60	0,60

1. Необходимо стремиться к наибольшей жесткости системы СПИД.
2. В случае изменения скорости резания V_c (количества оборотов/мин, N), скорость подачи (V_f) необходимо пропорционально изменить.
3. При увеличении вылета инструмента требуется уменьшить обороты и скорость подачи.
4. Режимы резания носят исключительно рекомендательный характер. Окончательные значения режимов резания уточняются на стадии отработки конкретной технологической операции в производственных условиях.

СЕРИИ WM067/WM068 (рабочая часть с внутренним радиусом)

Фрезы твердосплавные концевые радиусные вогнутые для общей универсальной обработки материалов 20–50 HRC: углеродистых, конструкционных, легированных и термоупрочненных сталей, нержавеющей сталей, чугунов.

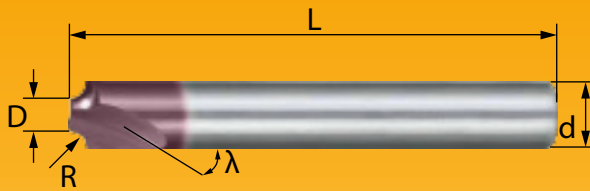

- Исполнение с высокотехнологичным покрытием AlTiCrN увеличивает износостойкость и снижает коэффициент трения.
- Предназначены для образования фасок с внешним радиусом.

Артикулы		R, мм	D, мм	L, мм	d, мм
z = 2, WM067~	z = 4, WM068~				
WM06702904H0050N	WM06802904H0050N	0,5	2,9	50	4
WM06704906H0050N	WM06804906H0050N	0,5	4,9	50	6
WM06701904H0100N	WM06801904H0100N	1,0	1,9	50	4
WM06703906H0100N	WM06803906H0100N	1,0	3,9	50	6
WM06705908H0100N	WM06805908H0100N	1,0	5,9	60	8
WM06704908H0150N	WM06804908H0150N	1,5	4,9	60	8
WM06705910H0200N	WM06805910H0200N	2,0	5,9	75	10
WM06704910H0250N	WM06804910H0250N	2,5	4,9	75	10
WM06705912H0300N	WM06805912H0300N	3,0	5,9	75	12
WM06703912H0400N	WM06803912H0400N	4,0	3,9	75	12
WM06705916H0500N	WM06805916H0500N	5,0	5,9	75	16
WM06703916H0600N	WM06803916H0600N	6,0	3,9	75	16

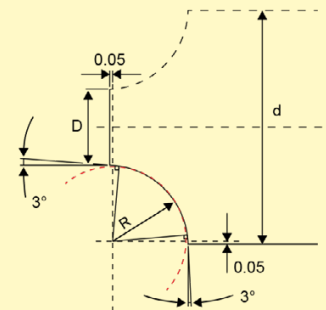

РЕЖИМЫ РЕЗАНИЯ ДЛЯ ФРЕЗ СЕРИЙ WM067/WM068

Материалы	Углеродистые стали / Легированные стали			Легированные стали / Инструментальные стали			Предварительно закаленные стали		
Твердость	HRC < 20			30–40 HRC			40–50 HRC		
V_c	30–40 м/мин			20–30 м/мин			15–25 м/мин		
D, мм	N, об./мин	Скорость черновой обработки, мм/мин	Скорость чистовой обработки, мм/мин	N, об./мин	Скорость черновой обработки, мм/мин	Скорость чистовой обработки, мм/мин	N, об./мин	Скорость черновой обработки, мм/мин	Скорость чистовой обработки, мм/мин
0,50	8800	50	80	6400	40	55	5100	30	50
0,75	7200	50	80	5100	40	55	4100	30	50
1,00	5000	50	80	3500	40	55	3400	30	50
1,25	4300	50	80	3100	40	55	2900	30	50
1,50	3000	50	80	2200	40	55	2600	30	50
2,00	2600	50	80	1900	40	55	2200	30	50
2,50	2200	50	80	1800	40	55	2000	30	50
3,00	2000	50	80	1600	40	55	1700	30	50
4,00	1500	50	80	1200	40	55	1300	30	50
5,00	1300	50	80	960	40	55	1000	30	50
6,00	1200	50	80	880	40	55	900	30	50

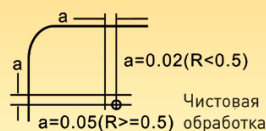
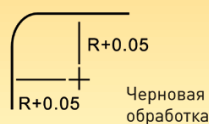

- Разделите глубину резания на несколько проходов.
- Используйте СОЖ.

1. Необходимо стремиться к наибольшей жесткости системы СПИД.
2. В случае изменения скорости резания V_c (количества оборотов/мин, N), скорость подачи (V_f) необходимо пропорционально изменить.
3. При увеличении вылета инструмента требуется уменьшить обороты и скорость подачи.
4. Режимы резания носят исключительно рекомендательный характер. Окончательные значения режимов резания уточняются на стадии отработки конкретной технологической операции в производственных условиях.